



ELECTRIC SERVICE REQUIREMENTS

2025 EDITION

November 18, 2025

Visit us at: <https://www.ladwp.com/codes>



NOTICE

This manual is for electronic distribution only and is designed to provide you with the most current information on the Los Angeles Department of Water and Power's (Department) service equipment and installation requirements. Every effort has been made to make this manual as complete and accurate as possible. These service requirements are subject to periodic revisions.

For assistance locating a contact for new or upgraded electrical services: www.ladwp.com/findtherightperson

For additional information or technical assistance regarding these requirements and for administrative inquiries regarding this ESR Manual or revisions, please contact the Utility Coordination Group

Los Angeles Department of Water and Power
Attn: Utility Coordination
Address: 2633 Artesian St,
Los Angeles, CA 90031
Email: pnbutilitycoordinator@ladwp.com

CONTENTSDate 05-02-24

	<u>PAGE</u>
SECTION 1 GENERAL INFORMATION	1-1
This section contains general service and policy information.	
SECTION 2 SERVICE AND METERING EQUIPMENT, 0-600 VOLTS	2-1
This section contains equipment requirements for wall-mounted metering equipment, service pedestals and underground supply terminating pull boxes.	
SECTION 3 LOW-VOLTAGE SWITCHBOARDS, 0-600 VOLTS	3-1
This section contains equipment requirements for low-voltage switchboard metering equipment, underground supply terminating pull sections and busway service heads.	
SECTION 4 MEDIUM-VOLTAGE SWITCHGEAR, 601-34,500 VOLTS	4-1
This section contains requirements for medium-voltage metering equipment and underground supply terminating pull sections.	
SECTION 5 DESIGN AND INSTALLATION GUIDE FOR SERVICE AND METERING EQUIPMENT	5-1
This section contains specifications to assist customers in designing and installing low-voltage and medium-voltage services.	
SECTION 6 DESIGN AND INSTALLATION GUIDE FOR ELECTRIC CONDUIT SYSTEMS ON PRIVATE PROPERTY	6-1
This section contains basic specifications to assist customers in designing and installing electric conduit systems on the customer's property.	
SECTION 7 DESIGN AND INSTALLATION GUIDE FOR OVERHEAD SERVICES, 0-600 VOLTS	7-1
This section contains specifications to assist customers in designing and installing low-voltage overhead electric services.	
SECTION 8 DESIGN GUIDE FOR CUSTOMER-OWNED PARALLEL GENERATING SYSTEMS	8-1
This section contains specifications to assist customers in designing self-generating and energy storage systems intended to operate in parallel with the Department's electric distribution system.	
SECTION 9 INDEX AND GLOSSARY	9-1
This section contains an index to assist customers in locating information in this manual, EUSERC/ESR acceptability table, summary of revisions, and a Glossary of common terms.	

GENERAL INFORMATIONDate: 10-31-25

CONTENTS

	<u>PAGE</u>
A. Office Locations, Telephone Assistance and Website Links	1-3
1. Engineering Offices	1-3
2. Service Planning Area Boundary Map	1-4
3. Customer Service Branch Offices	1-5
4. Telephone Numbers	1-5
5. Website Links	1-6
B. Planning Electric Services	1-7
1. Initial Contact	1-7
2. Plan Submittals	1-7
3. Service Confirmations and Facilities Requirements	1-7
4. Applications for Service	1-7
5. Fees and Charges	1-7
6. Permits and Inspections	1-8
7. Scheduling and Construction	1-8
8. Project Status and Scheduling Information	1-8
9. Time-Lines for Installation of Electric Services	1-9
a. Underground Residential Services	1-9
b. Overhead Residential Services	1-10
c. Underground Commercial, Light Industrial, and Large Residential Services	1-11
d. Overhead Commercial, Light Industrial, and Large Residential Services	1-12
e. Services Supplied from Customer Station Installations	1-13
f. Temporary Services	1-14
(1) Temporary Services, Overhead	1-14
(2) Temporary Services, Underground	1-15
g. Parallel-Generation Installations	1-16
h. Electric Vehicle (EV) Services	1-18
Service Planning Information Form	1-19
i. Cancellation Policy	1-21
C. Electric Load	1-21
1. General	1-21
2. Changes in Connected Load	1-21
3. Insufficient Load	1-22
4. Load Characteristics Affecting Other Customers	1-22
5. Single-Phase Motors	1-22
6. Three-Phase Motors	1-22
7. Lighting	1-22
8. Heating, Cooking, and Miscellaneous Loads	1-22
9. X-Rays Units over 5 kVA	1-23
10. Welders	1-23
11. Electric Vehicle (EV) Load Management Systems	1-23
12. Special Equipment	1-23
D. Inspections	1-24
1. General	1-24
2. Scheduling Inspections	1-24
3. Special Inspections	1-24
E. Service Voltages	1-25
1. Character of Service	1-25
2. Service Supply Voltages	1-25
3. Acceptable Voltage Ranges	1-26

Date: 10-01-25

GENERAL INFORMATION

CONTENTS (Cont.)

	<u>PAGE</u>
F. Classes of Service	1-27
G. Short-Circuit Current and Overcurrent Protection	1-28
H. Temporary Services	1-29
1. Application Fees and Charges	1-29
2. Permits and Approvals	1-29
3. Time Limitations	1-29
4. Removal of Service	1-29
5. Installation Requirements	1-30
I. Flat Connected Services	1-31
1. General	1-31
2. Emergency Flat Services	1-31
3. Building or Service Alterations	1-31
J. Customer-Owned Generators	1-32
A. Emergency or Stand-by Generators	1-32
B. Customer-owned Parallel-Generation Systems	1-32
K. Transformer Installations on the Customer's Premises	1-34
1. General	1-34
2. Transformer Installations	1-34
a. Pole-Mounted Transformer Installations	1-34
b. Padmount Transformer Installations	1-35
c. Underground Vault Transformer Installations	1-35
d. Outdoor Transformer Installations	1-35
e. Indoor Transformer Installations	1-35
3. Standard Installations	1-36
4. Charges for Nonstandard Installations	1-36
5. Access and Clearances	1-36
6. Customer Stations	1-37
a. General	1-37
b. Redesigns and Cancellations	1-37
c. Insufficient Load	1-37
d. Scheduled Maintenance/Standby Generators	1-38
L. Fire Pump Service	1-38
M. Parallel Connection of Utility Sources	1-38
N. Customer-Owned Instrument Transformers and Protective Devices	1-39
O. Scheduling Outages	1-39
P. Certification of Meter and Service Equipment	1-39
Q. Labeling of Meter and Service Equipment	1-39
R. Adjustable/Programmable Breakers	1-40

GENERAL INFORMATIONDate: 05-02-24

A. OFFICE LOCATIONS, TELEPHONE ASSISTANCE AND WEBSITE LINKS**1. ENGINEERING OFFICES****a. VALLEY SERVICE PLANNING OFFICE** (see Area Boundary Map)

7501 Tyrone Avenue - located north of Covello St.
Van Nuys, CA 91405

Tel (818) 771-4100, FAX (818) 771-4066, Email: PowerNewBusinessVSP@ladwp.com

b. METROPOLITAN SERVICE PLANNING OFFICE (see Area Boundary Map)

2633 Artesian Street, Room 210 - located at Avenue 26 between Lacy St and Humboldt St.
Los Angeles, CA 90031

Tel (213) 367-6000, FAX (213) 367-6027, Email: PowerNewBusinessMSP@ladwp.com

c. CUSTOMER STATION DESIGN GROUP: Serves customized new and existing Customer Station projects throughout the Department's service area including the Owens Valley area.

2633 Artesian Street, Room 270 - located at Avenue 26 between Lacy St and Humboldt St.
Los Angeles, CA 90031

Tel (213) 367-8028, FAX (213) 367-8099, Email: CustomerStationDesign@ladwp.com

d. ELECTRIC VEHICLE (EV) SERVICE DESIGN GROUP: Serves electric vehicle charging projects throughout the Department's service area including the Owens Valley area.

2633 Artesian Street, Room 210 - located at Avenue 26 between Lacy St and Humboldt St.
Los Angeles, CA 90031

Tel (213) 367-6008, Email: COMM.SVC_EVRequest@ladwp.com

e. PHOTOVOLTAIC AND BATTERY ENERGY STORAGE (PV/BESS) SERVICE DESIGN GROUP: Serves cogeneration and energy storage projects throughout the Department's service area including the Owens Valley area.

2633 Artesian Street, Room 210 - located at Avenue 26 between Lacy St and Humboldt St.
Los Angeles, CA 90031

Tel (818) 771-3622, Email: PV-BESSCustomerSubmittals@ladwp.com

f. TRACT DESIGN GROUP: Serves housing tract projects of 5 or more single-family residences on individual lots, annexations, mobile home parks (mobile or manufactured homes) and RV parks throughout the Department's service area including the Owens Valley and fringe areas.

2633 Artesian Street, Room 210 - located at Avenue 26 between Lacy St and Humboldt St.
Los Angeles, CA 90031

Tel (213) 367-8079, FAX (213) 367-8099, Email: TractDesign@ladwp.com

g. TELECOMMUNICATIONS GROUP: Serves CATV and cellular telephone projects throughout the Department's service area except the Owens Valley area.

111 No. Hope Street - located at the corner of Hope St and First St.
Room 869
Los Angeles, CA 90012

Tel (213) 367-3369, FAX (213) 367-3680, Email: TelecomServiceDesign@ladwp.com

A. OFFICE LOCATIONS, TELEPHONE ASSISTANCE AND WEBSITE LINKS (Cont.)

2. SERVICE PLANNING AREA BOUNDARY MAP (For service planning office addresses and telephone numbers, see page 1-3)

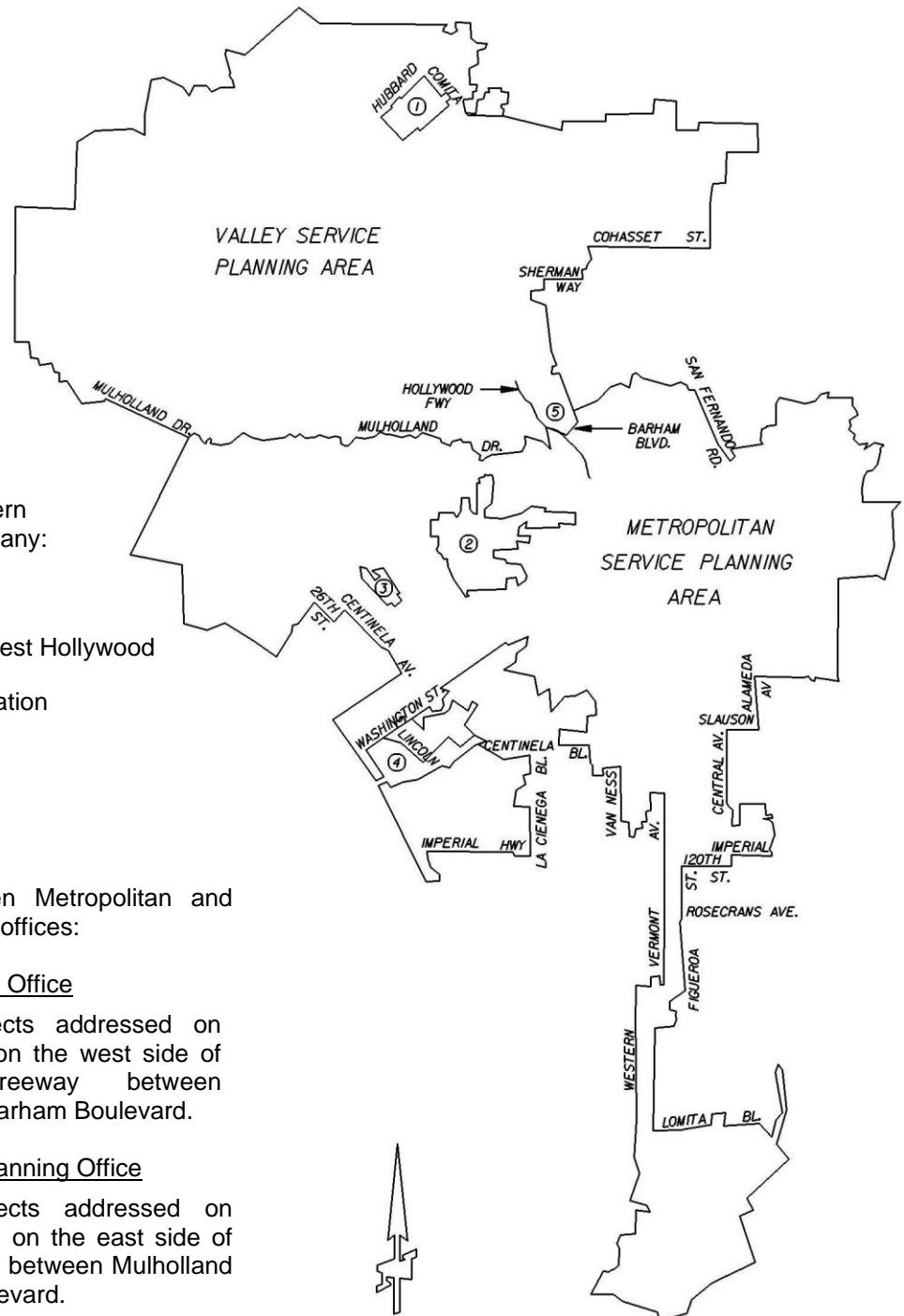

Areas served by Southern California Edison Company:

1. San Fernando
2. Beverly Hills and West Hollywood
3. Veterans Administration
4. Marina Del Rey
5. Universal Studios

Boundary line between Metropolitan and Valley service planning offices:

Valley Service Planning Office

Responsible for projects addressed on Mulholland Drive and on the west side of the Hollywood Freeway between Mulholland Drive and Barham Boulevard.

Metropolitan Service Planning Office

Responsible for projects addressed on Barham Boulevard and on the east side of the Hollywood Freeway between Mulholland Drive and Barham Boulevard.

GENERAL INFORMATIONDate: 05-02-24

A. OFFICE LOCATIONS, TELEPHONE ASSISTANCE AND WEBSITE LINKS (Cont.)**3. CUSTOMER SERVICE BRANCH OFFICES****a. METROPOLITAN AND WEST LOS ANGELES AREA OFFICES:**

<u>Branch Office</u>	<u>Address</u>
Main Office (Lobby)	111 N. Hope St. (corner of First Street and Hope Street)
Boyle Heights	919 S. Soto St., Suite 10 (south of Whittier Blvd)
Central	4619 S. Central Ave. (47 th Street and Central Avenue)
Crenshaw/Baldwin Hills	4030 Crenshaw Blvd. (Crenshaw Blvd and Martin L. King Blvd)
Hollywood	6547 Sunset Blvd, Suite B. (Sunset Blvd at Schrader Blvd)
Lincoln Heights	2417 Daly Street (north of North Broadway)
Slauson-Vermont	5928 S. Vermont Ave. (one block south of Slauson Ave)
Watts	1686 E. 103 rd St. (103 rd St and Graham Ave)
West Los Angeles	1394 S. Sepulveda Blvd (between Wilshire Blvd and Santa Monica Blvd)

b. SAN FERNANDO VALLEY OFFICES:

<u>Branch Office</u>	<u>Address</u>
Canoga Park	7229 Winnetka Ave. (Winnetka Ave and Sherman Way)
Mission Hills	11100 Sepulveda Blvd., Suite 3 (at San Fernando Mission Blvd)
Van Nuys	6550 Van Nuys Blvd. (between Haynes St and Kittridge St)

c. HARBOR AREA OFFICES:

<u>Branch Office</u>	<u>Address</u>
San Pedro	535 W. 9 th St. (between Pacific Ave and Gaffey St)
Wilmington	931 N. Avalon Blvd. (between Anaheim St and Pacific Coast Hwy)

d. OWENS VALLEY OFFICE:

<u>Branch Office</u>	<u>Address</u>
Bishop	300 Mandich Street. (between Fowler and Main St.)

Note: For additional payment centers, visit the Department's website at LADWP.com**4. TELEPHONE NUMBERS**

- a. For **SPEECH AND HEARING IMPAIRED/TTY**, call (800) 432-7397
- b. To make **APPLICATIONS FOR ELECTRIC SERVICE**, call
- (1) Residential (800) 342-5397
- (2) Commercial (800) 499-8840

A. OFFICE LOCATIONS, TELEPHONE ASSISTANCE AND WEBSITE LINKS (Cont.)

4. TELEPHONE NUMBERS (Cont.)

- c. Information concerning **INTERCONNECTION AGREEMENTS**:
 - (1) For all Solar, Wind, Fuel Cell, Micro Turbine, BESS and any other parallel generation or energy storage greater than 10kW, call (213) 367-6163
- d. For information concerning **ENERGY CONSERVATION, EFFICIENCY PROGRAMS** and **DEMAND-SIDE MANAGEMENT PROGRAMS** call (800) 827-5397
- e. For information concerning **ELECTRIC RATES**, call (213) 367-0329
- f. For information concerning **ELECTRIC AND MAGNETIC FIELDS (EMF)**, call (213) 367-2616
- g. For information regarding **POWER QUALITY**, call (213) 367-6080
- h. For information regarding **CONDUIT AND SUBSTRUCTURE LOCATION AND MARKING**, call Underground Service Alert (Dig Alert) at:
 - (1) National one-call number 8-1-1
- h. Customer Service 24 Hour Phone Numbers: To report **ELECTRIC OUTAGES, DOWNED POWER LINES** or other **ELECTRIC HAZARDS**, call:
 - (1) Local calls (818) 342-5397
 - (2) Toll free (800) 342-5397
- i. For information concerning the **INSTALLATION OF A NEW ELECTRIC SERVICE, SOLAR INTERCONNECTIONS**, or to **LOCATE A SERVICE PLANNER**, call (213) EMPOWER or .. (213) 367-6937
- j. For **MAXIMUM DEMAND REPORTS**, call (213) EMPOWER or (213) 367-6937
- k. For information concerning **SOLAR AND ELECTRIC VEHICAL (EV) BILLING**, call (866) 484-0433
- l. For **CONSTRUCTION NEAR POWER EQUIPMENT, RIGHT OF WAYS, EASEMENTS**, call .. (213) 367-0562
- m. For **NEW ELECTRIC SERVICE STATUS** (Connection Center), call 213-EMPOWER or ... (213) 367-6937

5. WEBSITE LINKS

- a. Los Angeles Department of Water and Power www.ladwp.com
- b. Find the Right Person (search by service address) www.ladwp.com/findtherightperson
- c. Project Status and Scheduling <https://wmis.powersystem.ladwp.com>
- d. Electric Service Requirements, Construction Standards and Rules www.ladwp.com/codes
- e. Electric Vehicles www.ladwp.com/ev
- f. Solar Programs www.ladwp.com/solar
- g. NEM, BESS and Cogeneration Interconnection and Application Process www.ladwp.com/nem
- h. Request a Meter Spot (single family residence only) www.ladwp.com/ams
- i. Request an Electrical Inspection www.ladwp.com/ir

GENERAL INFORMATIONDate: 05-02-24

B. PLANNING ELECTRIC SERVICES**1. INITIAL CONTACT**

When considering the design of electrical facilities for a residential, commercial, or industrial premises, customers should contact the Department service planning office in the area where service is to be supplied as soon as possible so that:

- a. The Department's service planning staff can work with the customer to establish a serving voltage and an acceptable meter and service location.
- b. Customers may avoid unnecessary expenses and delays in service caused by assuming the type of service the Department will provide

2. PLAN SUBMITTALS

At the time of initial contact with a Department engineering office, please provide the following items:

- a. A completed Service Planning Information sheet - see pages 1-19 and 1-20 for master copy with a fillable PDF version available at www.ladwp.com/forms.
- b. Electrical plans including load schedules, single-line diagrams, and equipment elevation drawings.
- c. Plot, grading, elevation, and site improvement plans.
- d. Any additional information requested by the service planner needed to assist the Department in finalizing the customer's plans.

3. SERVICE CONFIRMATIONS AND FACILITIES REQUIREMENTS

- a. **For projects to be served underground**, the Department will provide a construction drawing or other documentation specifying the facilities that the customer must install on the customer's premises to accommodate the Department's transformers, cables and any other equipment needed to supply the customer's load.
- b. **For projects to be served overhead**, the Department will provide a written confirmation of the serving pole and its location. The customer is responsible for designing and building the service entrance and point of attachment facilities to meet the Department's overhead service requirements. See Section 7 for the applicable design information.

4. APPLICATIONS FOR SERVICE

- a. Customers must contact a Customer Service Branch Office to make application for electric service. This should be done at the time of initial contact with an engineering office, or shortly after, to avoid delays in establishing service.
- b. For locations and telephone numbers of Department engineering offices, see page 1-3.

5. FEES AND CHARGES

Customers must make payment in full for all fees and charges assessed by the Department before construction will be started or service will be established. Such fees and charges include but are not limited to service application fees, charges for temporary services, charges for construction or relocation of Department facilities, charges for line extensions or excess conductor allowances as specified in the Rules, charges for interconnection of customer-owned generation facilities and charges for nonstandard installations.

Date: 05-02-24

GENERAL INFORMATION

B. PLANNING ELECTRIC SERVICES (Cont.)**6. PERMITS AND INSPECTIONS**

- a. The Department will energize a customer's electric service only after the installation has been inspected and cleared by both the Department and the permitting agency.
- b. Normally the following steps must be completed to establish electric service:
 - (1) An electrical permit must be obtained by the customer from the permitting agency.
 - (2) All site electrical wiring must be completed and inspected by the permitting agency and the final electrical release cleared to the Department (notice is generally made by teletype or letter).

Note: It may take several days after the final permitting agency inspection for the Department to be notified.
 - (3) All facilities specified by the Department must be inspected by the Department and all corrections must be completed and approved. See page 1-24 for additional information.

7. SCHEDULING AND CONSTRUCTION

- a. When the required inspections have been completed and all fees and charges are paid in full, a "release" will be sent to the appropriate Department service center for scheduling and construction.
- b. Installation of facilities by the Department will normally be scheduled during regular working hours. However, customers may request the Department to install facilities during premium (overtime) hours for the convenience of the customer. Requests for premium time installations may be made by contacting the appropriate engineering office. Customers are required to reimburse the Department for all premium time charges.
- c. The Department will make a reasonable effort to complete service installations as quickly as possible. However, the time required to complete an installation will vary according to the complexity of the service and the number of services already scheduled or under construction.
- d. The following timelines are provided to assist customers in planning and scheduling projects for:
 - (1) Underground residential services, see page 1-9.
 - (2) Overhead residential services, see page 1-10.
 - (3) Underground commercial, light industrial, and large residential services, see page 1-11.
 - (4) Overhead commercial, light industrial, and large residential services, see page 1-12.
 - (5) Customer Station installations (projects involving the Customer Station Design group), see page 1-13.
 - (6) Temporary Services, see pages 1-14.
 - (7) Parallel-generation installations, see pages 1-16.
 - (8) Electric Vehicle (EV) services, see page 1-18.

8. PROJECT STATUS AND SCHEDULING INFORMATION

Customers may track the progress of new electric service installations and upgrades by address by visiting the Power System Work Request Information System page on the Department's website at <https://wmis.powersystem.ladwp.com>.

B. PLANNING ELECTRIC SERVICES (Cont.)

9. TYPICAL TIME-LINES FOR INSTALLATION OF ELECTRIC SERVICES

a. UNDERGROUND RESIDENTIAL SERVICES

To expedite the installation of single-family residential electric services supplied from underground facilities, the Department recommends that work be scheduled in the following sequence:

- Customer's building design and construction activities
- Customer submits request for electric service (1)
- Department provides customer with requirements for electric service (4)
- Customer installs on-site conduit and/or substructures (2)
- Department inspects and releases on-site conduit and/or substructures
- Department installs cables, transformers and other equipment in conduits and/or substructures (3)
- Customer completes electrical installation
- Inspection and approval by permitting agency
- Final Department inspection and release of service and metering equipment (4)
- Department energizes service and sets meter (3)

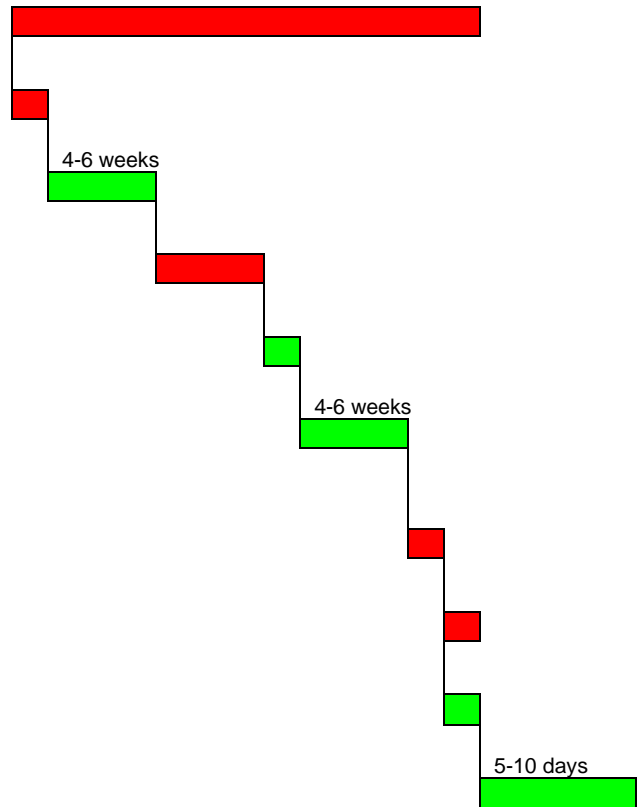

■ Customer Controlled ■ Department Controlled

- (1) Includes complete set of site and electrical plans required to evaluate and design service.
- (2) This work must be completed 4 to 6 weeks prior to the completion of the customer's building construction to allow the Department sufficient time to install the required cables and transformers. This will enable the Department to provide electric service in a matter of days after the Department receives the final release from the permitting agency, assuming the service application has been submitted and any required fees or deposits have been paid.
- (3) The Department will make a reasonable effort to complete service installations as quickly as possible. However, the time required to complete an installation will vary according to the complexity of the service and the number of services already scheduled or under construction.
- (4) Due to current workload and resources, project timelines may vary. Please contact your assigned LADWP design engineer or ESR for the current trending timelines expected for your project.

B. PLANNING ELECTRIC SERVICES (Cont.)

b. OVERHEAD RESIDENTIAL SERVICES

To expedite the installation of single-family residential electric services supplied from overhead facilities, the Department recommends that work be scheduled in the following sequence:



- (1) Includes complete set of site and electrical plans required to evaluate and design service.
- (2) The Department will make a reasonable effort to complete service installations as quickly as possible. However, the time required to complete an installation will vary according to the complexity of the service and the number of services already scheduled or under construction.
- (3) For services rated up to 200 amperes single phase, the Los Angeles Department of Building and Safety inspectors will provide the final inspection for the Department.
- (4) Due to current workload and resources, project timelines may vary. Please contact your assigned LADWP design engineer or ESR for the current trending timelines expected for your project.

B. PLANNING ELECTRIC SERVICES (Cont.)

c. UNDERGROUND COMMERCIAL, LIGHT INDUSTRIAL AND LARGE RESIDENTIAL SERVICES

To expedite the installation of commercial, light industrial, and large residential electric services supplied from underground facilities, the Department recommends that work be scheduled in the following sequence:

- Customer's building design and construction activities
- Customer submits request for electric service (1)
- Department provides customer with requirements for electric service (4)
- Customer installs on-site conduit and/or substructures (2)
- Department inspects and releases on-site conduit and/or substructures
- Department installs cables, transformers and other equipment in conduits and/or substructures (3)
- Customer completes electrical installation
- Inspection and approval by permitting Agency
- Final Department inspection and release of service and metering equipment (4)
- Department energizes service and sets Meter (3)

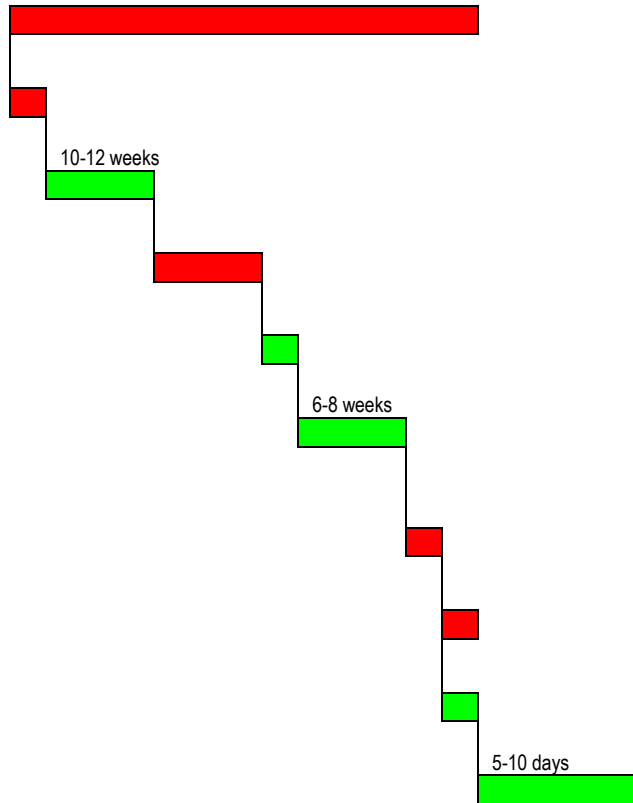

■ Customer Controlled ■ Department Controlled

- (1) Includes complete set of site and electrical plans required to evaluate and design service.
- (2) This work must be completed 4 to 6 weeks prior to the completion of the customer's building construction to allow the Department sufficient time to install the required cables and transformers. This will enable the Department to provide electric service in a matter of days after the Department receives the final release from the permitting agency, assuming the service application has been submitted and any required fees or deposits have been paid.
- (3) The Department will make a reasonable effort to complete service installations as quickly as possible. However, the time required to complete an installation will vary according to the complexity of the service and the number of services already scheduled or under construction.
- (4) Due to current workload and resources, project timelines may vary. Please contact your assigned LADWP design engineer or ESR for the current trending timelines expected for your project.

B. PLANNING ELECTRIC SERVICES (Cont.)

d. OVERHEAD COMMERCIAL, LIGHT INDUSTRIAL AND LARGE RESIDENTIAL SERVICES

To expedite the installation of commercial, light industrial, and large residential electric services supplied from overhead facilities, the Department recommends that work be scheduled in the following sequence:

- Customer's building design and construction activities
- Customer submits request for electric service (1)
- Department provides customer with requirements for electric service (3)
- Customer installs service and metering equipment
- Department installs off-site conductors, transformers, and other facilities (2)
- Inspection and approval by permitting agency
- Final Department inspection and release of service and metering equipment (3)
- Department energizes service and sets meter (2)

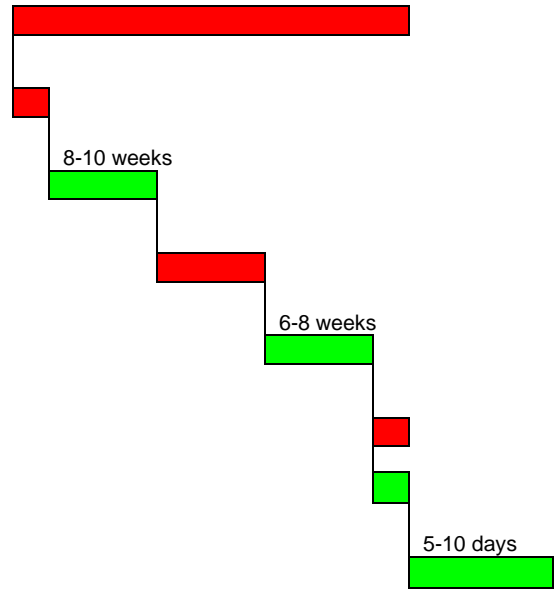

Customer Controlled
 Department Controlled

- (1) Includes complete set of site and electrical plans required to evaluate and design service.
- (2) The Department will make a reasonable effort to complete service installations as quickly as possible. However, the time required to complete an installation will vary according to the complexity of the service and the number of services already scheduled or under construction.
- (3) Due to current workload and resources, project timelines may vary. Please contact your assigned LADWP design engineer or ESR for the current trending timelines expected for your project.

B. PLANNING ELECTRIC SERVICES (Cont.)

e. SERVICES SUPPLIED FROM CUSTOMER STATION INSTALLATIONS

To expedite the installation of commercial, light industrial, and large residential electric services supplied from customer station facilities, the Department recommends that work be scheduled in the following sequence:

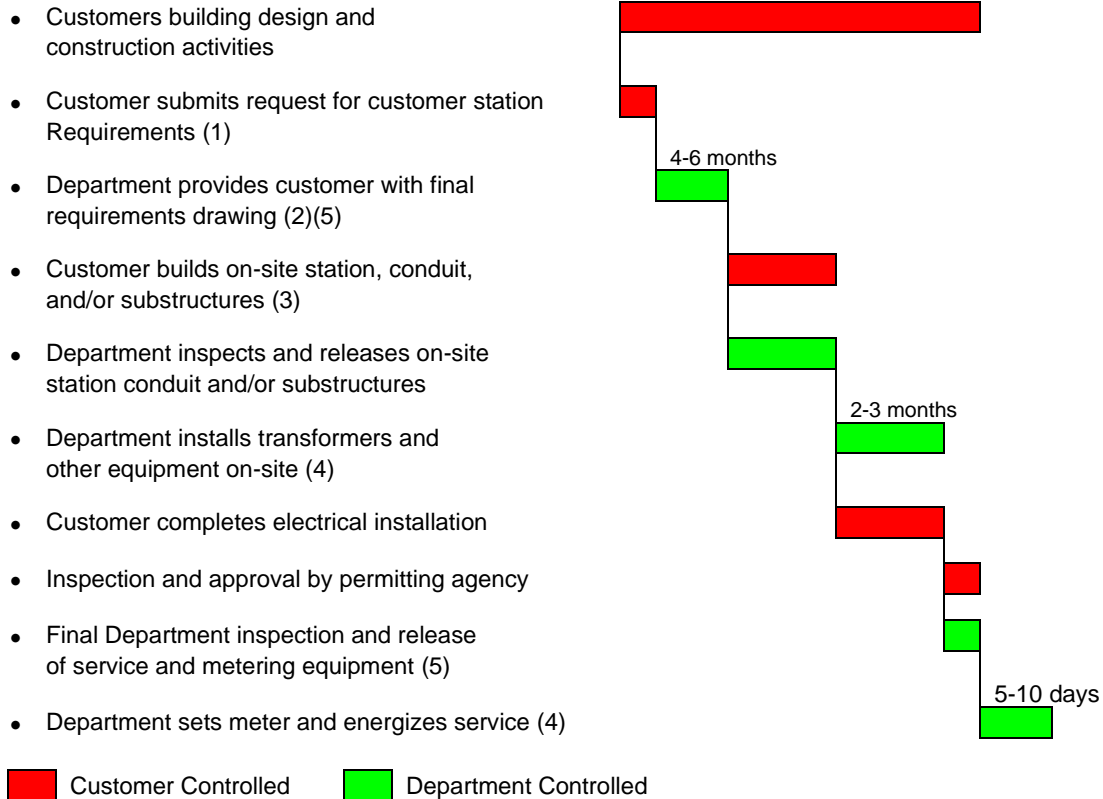

- (1) Includes complete set of site and electrical plans required to evaluate and design service.
- (2) The Department will provide preliminary requirements drawings upon request within 2 to 3 months upon request.
- (3) This work must be completed 4 to 5 months prior to the anticipated in-service-date to allow the Department sufficient time to install transformers and other equipment in the station. This will enable the Department to provide electric service in a matter of days after the Department completes the installation and receives the final release from the permitting agency, assuming the service application has been submitted and any required fees or deposits have been paid.
- (4) The Department will make a reasonable effort to complete service installations as quickly as possible. However, the time required to complete an installation will vary according to the complexity of the service and the number of services already scheduled or under construction.
- (5) Due to current workload and resources, project timelines may vary. Please contact your assigned LADWP design engineer or ESR for the current trending timelines expected for your project.

B. PLANNING ELECTRIC SERVICES (Cont.)

f. TEMPORARY SERVICES

To expedite the installation of temporary electric services, the Department recommends that work be scheduled in the following sequence for:

1. OVERHEAD SERVICES

a) Requiring installation of a meter, service drop conductors, and construction of Department facilities:

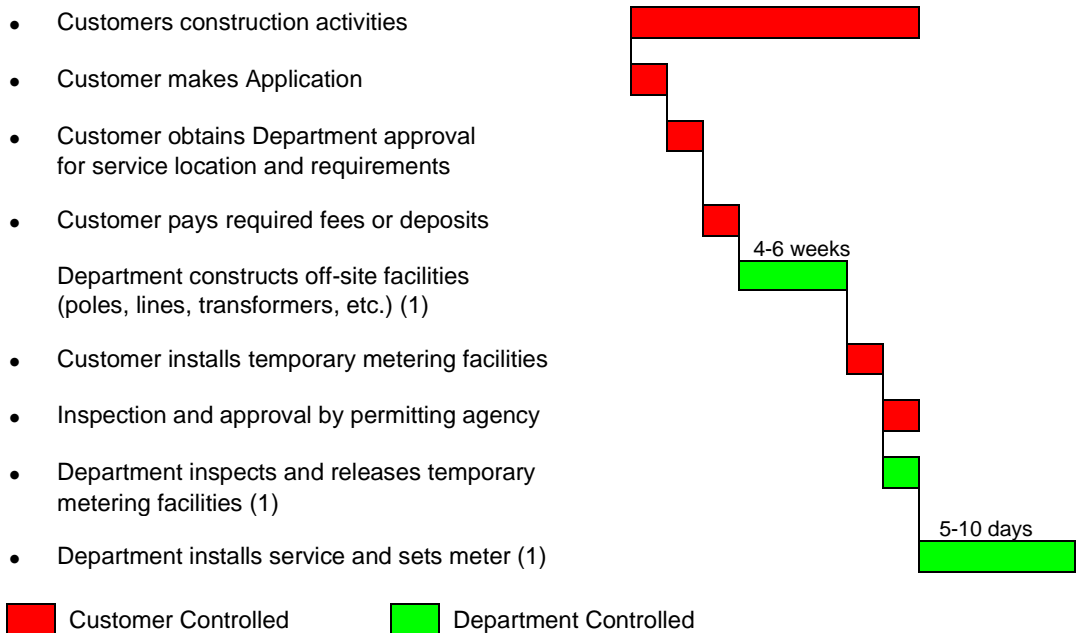

b) Requiring only the installation of a meter and service drop conductors:

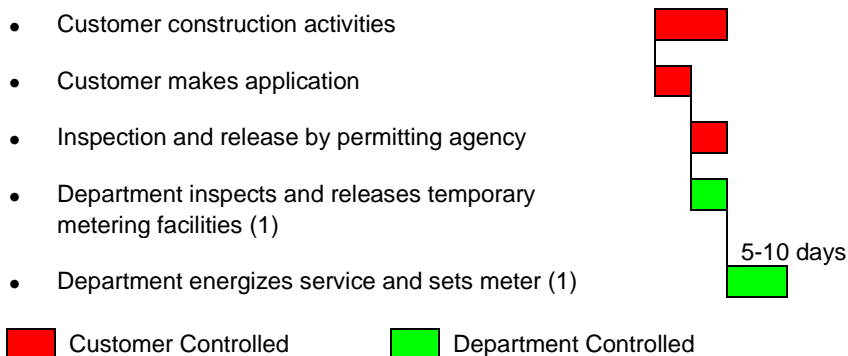

(1) Due to current workload and resources, project timelines may vary. Please contact your assigned LADWP design engineer or ESR for the current trending timelines expected for your project.

B. PLANNING ELECTRIC SERVICES (Cont.)

2. UNDERGROUND SERVICES

Requiring installation of a meter, underground service entrance conductors, and construction of Department facilities:

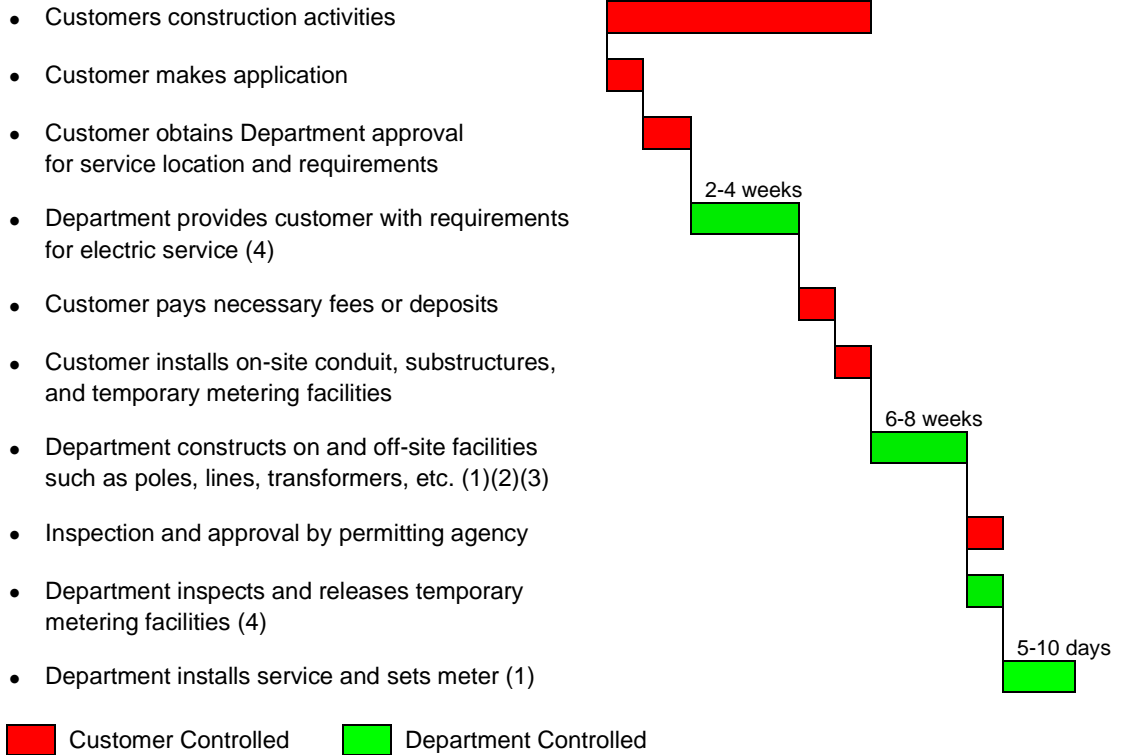

- (1) The Department will make a reasonable effort to complete service installations as quickly as possible. However, the time required to complete an installation will vary according to the complexity of the service and the number of services already scheduled or under construction.
- (2) Typical times for services exceeding 200 amperes.
- (3) For services requiring engineering for conduit construction in public property, the customer should provide an additional 8 to 16 weeks in the construction schedule to allow the Department to plan for conduit construction and obtain a permit from the Los Angeles Department of Public Works.
- (4) Due to current workload and resources, project timelines may vary. Please contact your assigned LADWP design engineer or ESR for the current trending timelines expected for your project.

B. PLANNING ELECTRIC SERVICES (Cont.)

g. PARALLEL-GENERATION INSTALLATIONS

To expedite the installation of generation facilities to the Department’s distribution system, the Department recommends that work be scheduled in the following sequence, not applicable to Feed-in Tariff projects, typical of a Type 2- PV/BESS Interconnection (6):

- Customer's generation design and construction activities
- Customer submits request for interconnection (1) and Generation Interconnection Agreement (Agreement) (6)(7)
- Department provides customer with Customer Data Sheet, Draft Agreement and other necessary information
- Customer submits required information
- Department provides customer with customer commitment package
- Customer returns executed Agreement (2)
- Department provides customer with Interconnection requirements (3)(5)(8) if applicable
- Department constructs distribution facilities required for interconnection (4) if applicable
- Customer completes construction of Interconnection facilities
- Department executes Agreement
- Inspection and approval by permitting agency
- Final Department inspection and release of service and metering equipment (5)
- Department energizes service and sets meter (4)

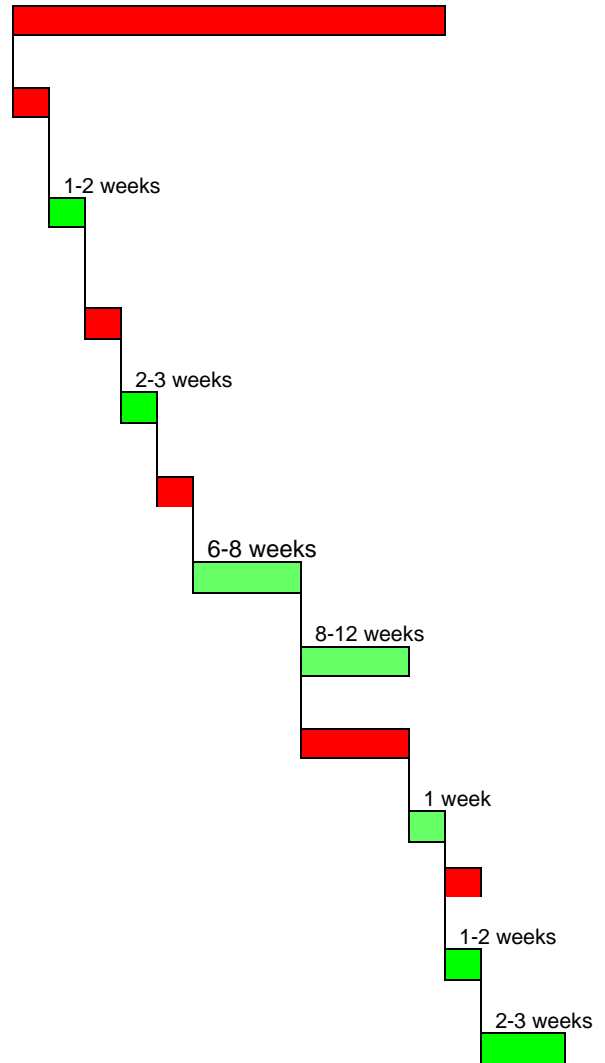

Customer Controlled Department Controlled

(1) The request for interconnection design must include the information specified on Page 8-2 under DATA REQUIRED FOR DESIGN.

(2) Department engineering will not start until the customer has returned the executed Interconnection Agreement.

GENERAL INFORMATIONDate: 05-02-24

B. PLANNING ELECTRIC SERVICES (Cont.)**g. PARALLEL-GENERATION INSTALLATIONS (Cont.)**

- (3) Department engineering time may vary with the complexity of the design and existing workloads.
- (4) The Department will make a reasonable effort to complete service installations as quickly as possible. However, the time required to complete an installation will vary according to the complexity of the service and the number of services already scheduled or under construction.
- (5) Due to current workload and resources, project timelines may vary. Please contact your assigned LADWP design engineer or ESR for the current trending timelines expected for your project.

- (6) **Type 1 PV/BESS** - Customers or contractors can apply under the Type 1 Interconnection Process for PV and/or BESS projects that meet Service Planning requirements.

Type 1 Interconnection Process should be followed if the proposed installation is up to and including 30kW aggregate system size and/or **does not include**: 1) a service panel upgrade; 2) a three (3) phase service connected to the customer's project; 3) ADUs; and 4) other multi-meter interconnection types i.e. not a single meter interconnection application.

Type 2 PV/BESS/COGEN - Customers or contractors can apply under the Type-2 Interconnection Process for PV and/or BESS projects that meet Service Planning requirements.

Type 2 Interconnection Process should be followed if the proposed installation is up to and including 30kW aggregate system size (or 10kW and below 3 phase) and **does include**: 1) a service panel upgrade; 2) multi-tenant dwelling on premises; 3) ADUs; and 4) other multi-meter interconnection types i.e. not a single meter interconnection application.

Type 3 PV/BESS/COGEN - Customers or contractors can apply for the Type 3 Interconnection Process for PV and/or BESS projects that meet Service Planning requirements. All system size ratings submitted as kW AC (battery) and kW AC-CEC (solar).

Type 3 Interconnection Process should be followed if the proposed installation is greater than 30kW and less than 1MW aggregate system size and/or **does include**: 1) a part of a new tract home project (i.e. five or more homes); 2) a three (3) phase service connected to the customer's project with aggregate system size greater than 10kW; 3) ADUs; and 4) other multi-meter interconnection types i.e. not a single meter interconnection application.

Type 4 COGEN ONLY - Customers or contractors can apply for the Type 4 Interconnection Process for PV, BESS and/or Cogeneration project that meet the following Service Planning requirements. All system size ratings submitted as kW AC and kW AC-CEC (solar), as applicable.

Type 4 Interconnection Process should be followed if the proposed installation is greater than 1MW (for PV and BESS) aggregate system size, for all non-NEM eligible cogeneration projects greater than 1MW aggregate system size.

- (7) Interconnection agreement packages for proposed customer-owned parallel-generation facilities may be obtained by contacting the following:
 - (a) Type 1, 2, 3 and 4 PV/BESS - parallel-generation and storage projects complete the application process online at www.ladwp.com/NEM.
 - (b) Interconnection Agreements call (213) 367-6163 or email at SolarCoordinator@ladwp.com.
 - (c) Solar parallel-generation under the Feed-in-Tariff (FiT) program, call (213) 367-2100. FiT documents, program guidelines, contracts/agreements and application forms may be found at Web page www.ladwp.com/fit. Customers may also contact FiT staff by email at fit@ladwp.com.

Additional solar program information and NEM forms are also available online at www.ladwp.com/solar.

- (8) After Engineering performs a preliminary review which usually takes 2-6 weeks and a complete customer submittal package has been confirmed.

B. PLANNING ELECTRIC SERVICES (Cont.)

h. SERVICES FOR ELECTRIC VEHICLE CHARGERS (EV)

To expedite the installation electric service feeding commercial and multi-family residential EV chargers supplied from overhead or underground facilities, the Department recommends that work be scheduled in the following sequence:

- Customer submits request for electric service (1)
- Department provides customer with requirements for electric service (4)
- Customer installs on-site conduit and/or substructures (2)
- Department inspects and releases on-site conduit and/or substructures
- Customer completes electrical Installation of EV chargers
- Department installs cables, transformers and other equipment in conduits and/or substructures (3)
- Inspection and approval by permitting Agency
- Final Department inspection and release of service and metering equipment (4)
- Department energizes service and sets Meter (3)

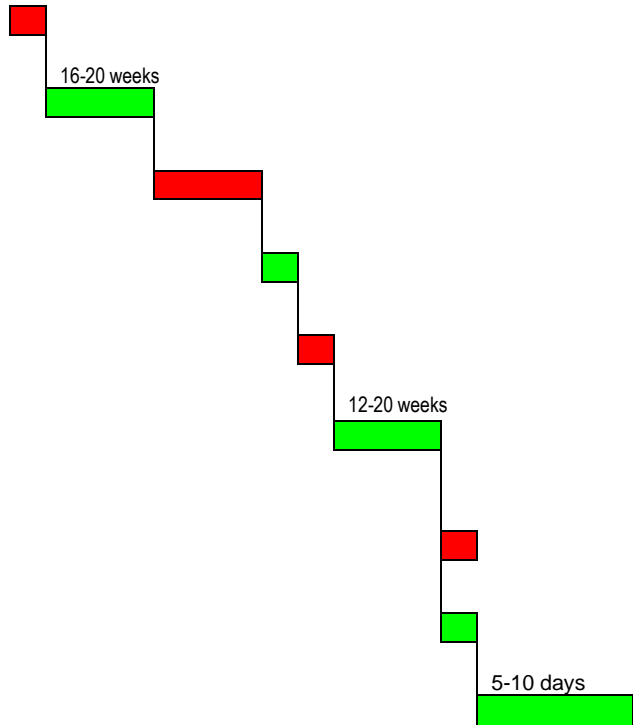

■ Customer Controlled ■ Department Controlled

- (1) Includes complete set of site and electrical plans required to evaluate and design service.
- (2) This work must be completed 4 to 6 weeks prior to the completion of the customer's building construction to allow the Department sufficient time to install the required cables and transformers. This will enable the Department to provide electric service in a matter of days after the Department receives the final release from the permitting agency, assuming the service application has been submitted and any required fees or deposits have been paid.
- (3) The Department will make a reasonable effort to complete service installations as quickly as possible. However, the time required to complete an installation will vary according to the complexity of the service and the number of services already scheduled or under construction.
- (4) Due to current workload and resources, project timelines may vary. Please contact your assigned LADWP design engineer or ESR for the current trending timelines expected for your project.

SERVICE PLANNING INFORMATION  Link to Forms & Publications: https://www.ladwp.com/forms		Metro East: 2633 Artesian St, Rm 210, Los Angeles 90031, Ph (213) 367-6000				
		Metro West: 2633 Artesian St, Rm 250, Los Angeles 90031, Ph (213) 367-6000				
		Valley: 7501 Tyrone Ave, Van Nuys, CA 91405, Ph (818) 771-4100				
		Tract: 2633 Artesian St, Rm 210, Los Angeles 90031, Ph (213) 367-8079				
		Cogen PV / BESS: 2633 Artesian St, Rm 210, Los Angeles 90031, Ph (818) 771-3622				
		Customer Station: 2633 Artesian St, Rm 270, Los Angeles 90031, Ph (213) 367-8028				
		Electric Vehicle: 2633 Artesian St, Rm 210, Los Angeles 90031, Ph (213) 367-6232				
		Connection Center: Ph (213) EMPOWER or (213) 367-6937				
1. Project Address: Number		Street	City	Zip Code	2. Service Wanted Date:	
3. Project Name		4. Nearest Cross Street		5. Tract Number	6. Lot Number	
7. Construction Type: (check all that apply) <input type="checkbox"/> New <input type="checkbox"/> Remodel <input type="checkbox"/> EV			8. Zoning: <input type="checkbox"/> Residential <input type="checkbox"/> Commercial <input type="checkbox"/> Industrial			
9. Onsite Parallel Generation: (check all that apply) <input type="checkbox"/> Solar (NEM) <input type="checkbox"/> Solar (FiT) <input type="checkbox"/> Wind <input type="checkbox"/> Fuel Cell <input type="checkbox"/> Energy Storage*					*Supplemental Data Sheet Required	
10. Number of Units:		12. Residential Size	13. Commercial Size	14. Total Building Size	15. Subterranean Garage	
11. Number of Stories:		sq. ft.	sq. ft.	sq. ft.	sq. ft.	
16. Project Methane Status (check one): <input type="checkbox"/> No methane present on the project site <input type="checkbox"/> Project site is located in a <u>designated methane zone</u> <input type="checkbox"/> Project site is located in a <u>designated methane buffer zone</u> – test data (methane concentration in ppmv and methane pressure in inches of water column) is required in order to provide service planning information. To obtain a report for methane and other property information, please visit http://zimas.lacity.org						
17. Legal Contact (Name):				18. Phone No.		
(Individual responsible for signing contracts, paying fees and receiving potential refunds)				19. E-mail Address:		
20. Address: Number		Street	Suite	City	Zip Code	
21. Plans Submitted By: <input type="checkbox"/> Owner <input type="checkbox"/> Electrical Engineer <input type="checkbox"/> Electrical Contractor <input type="checkbox"/> General Contractor <input type="checkbox"/> Architect						
22. Plans Submitted By (Name):				23. Phone No.		
24. Company Name:				25. E-mail Address:		
26. Address: Number		Street	Suite	City	Zip Code	
27. Property Owner (Name):				28. Phone No.		
29. Address: Number		Street	Suite	City	Zip Code	
30. Service Type Requested: <input type="checkbox"/> Permanent Overhead <input type="checkbox"/> Temporary Overhead <input type="checkbox"/> Permanent Underground <input type="checkbox"/> Temporary Underground				31. Construction Start Date:		
32. Other Work Requested: <input type="checkbox"/> Removal of Power Facilities <input type="checkbox"/> OH to UG Conversion <input type="checkbox"/> OH Encroachment						
33. Service Voltage: (check one)		<input type="checkbox"/> 120/240V 1Ø,3-wire		<input type="checkbox"/> 240Δ/120V 3Ø,4-wire		<input type="checkbox"/> 208Y/120V 3Ø,4-wire
		<input type="checkbox"/> 480Y/277V 3Ø,4-wire		<input type="checkbox"/> 4160V 3Ø,3-wire		<input type="checkbox"/> 4800V 3Ø,3-wire
		<input type="checkbox"/> 34,500V 3Ø,3-wire		<input type="checkbox"/> other: _____ volt		<input type="checkbox"/> Ø -wire
34. Service Equipment Rating: (check one)		<input type="checkbox"/> 100 amps <input type="checkbox"/> 200 amps <input type="checkbox"/> 320 amps <input type="checkbox"/> 400 amps <input type="checkbox"/> 600 amps		<input type="checkbox"/> 800 amps <input type="checkbox"/> 1200 amps <input type="checkbox"/> 1600 amps <input type="checkbox"/> other: _____ amps		
35. Meter Disconnect Rating: (check one)		<input type="checkbox"/> 100 amps <input type="checkbox"/> 200 amps <input type="checkbox"/> 400 amps <input type="checkbox"/> 600 amps <input type="checkbox"/> 800 amps		<input type="checkbox"/> 1200 amps <input type="checkbox"/> 1600 amp <input type="checkbox"/> 2000 amps <input type="checkbox"/> 2500 amps <input type="checkbox"/> 3000 amps		
		<input type="checkbox"/> 4000 amps <input type="checkbox"/> 5000 amps <input type="checkbox"/> other: _____ amps				

36. Load Summary: (complete one (1) load summary for each point of service)					
Service Point No.		House (Non-Tenant) Loads		Tenant Loads	
Electric Loads	Largest Unit	1Ø	3Ø	1Ø	3Ø
Air Conditioning (kW)					
Auxiliary Strip Heating (kW)					
Cooking (kW)					
Elevators (hp)					
EV Chargers (Also Complete Box 37) (kW)					
General Power (kW)					
Heat Pumps (kW)					
Lighting (kW)					
Motors (hp)					
Receptacles (kW)					
Refrigeration (kW)					
Water Heater (kW)					
Other Loads:					
a:					
b:					
c:					
Total:					
37. EV Chargers (total number)					
Level 1 () @120V					
Level 2 () @208/240V					
Level 3 () @480V					
38. Largest Motor		39. Rated HP		40. Locked-Rotor Current	
41. Motors - 40 HP and above		42. Rated HP		43. Locked-Rotor Current	
				44. Motor Use	
45. Back up or Emergency Power Generator Switching Information:					
<input type="checkbox"/> <u>Open-Transition Switch</u>					
Manufacturer & Model number: _____					
<input type="checkbox"/> <u>Closed Transition Switch:</u>					
Duration of Parallel Operation: <input type="checkbox"/> One Second or Less <input type="checkbox"/> More than One Second					
Manufacturer & Model number: _____					
<input type="checkbox"/> <u>Programmable Switch:</u>					
Duration of Parallel Operation in Closed Transition Mode: <input type="checkbox"/> One Second or Less <input type="checkbox"/> More than One Second					
Manufacturer & Model number: _____					
Notes: Switches that operate in parallel with the Department's electric system for one second or less require that a <u>Certificate of Momentary Operation</u> be completed and filed with the Department.					
Switches that operate in parallel for more than one second require a that an <u>Interconnection Agreement</u> be completed and filed with the Department.					
46. Additional Comments:					

Submitted By: _____ Date: _____
Print Name Signature

GENERAL INFORMATIONDate: 10-01-25

B. PLANNING ELECTRIC SERVICES (Cont.)**i. Cancellation Policy**

This policy applies to all projects in submittal, design, and construction phases.

For projects in the submittal phase, requests that are submitted but which still need documents or other requirements to be completed by the customer within six weeks of initial submittal will be cancelled upon notification by email thereof from the Department.

Projects in the design phase for which information is due from the customer will be placed on hold for thirty days upon the customer being notified by the first hold email indicating the pending information. If a satisfactory customer response was not provided within thirty days from the first hold email, a second hold email will be sent to the customer, with an additional thirty days allowed for a satisfactory response. If no satisfactory response is received from the customer within thirty days after the second hold email, such a customer will be advised that their project will be cancelled thirty days after the second hold email was sent, unless the necessary information from the customer is provided by then or if the Department agrees otherwise.

Projects in the construction phase will be cancelled if safety hazards are detected and not corrected by the customer upon notification by email from the Department, unless otherwise agreed upon by a manager in the Department's New Business and Electrification Division. Moreover, if no inspection by the Department has taken place for one year from the last inspection to the project site, the Department will send hold and cancellation emails, as conducted in the design phase.

Customers will be notified before project cancellations and asked to resolve any pending issues. Cancelled projects will need to be resubmitted to the Department to reinstate these projects. Cancellation of a project by the Department shall not affect the obligation of the customer to pay the Department for work already performed by the Department relating to the project prior to said cancellation.

C. ELECTRIC LOADS**1. GENERAL**

- a. Motor or lighting loads may be supplied from any service of appropriate class, phase, and voltage. However, such loads are subject to conditions or limitations specified in these service requirements and the Department's Rules.
- b. 120-volt single-phase loads must be reasonably balanced between phases with respect to the neutral, and 240-volt single-phase loads must be reasonably balanced between the phases.

2. CHANGES IN CONNECTED LOAD

- a. The customer shall provide written notice whenever a material change is made in the amount or character of the customer's electrical load, see page 1-19.
- b. The Department is required to serve only the load initially approved and connected, or specified, regardless of the rating of the service equipment or service disconnect.
- c. When a customer proposes adding load to an existing service, the added load is considered to be a new installation. The Department will consider the added loads on an individual basis and reserves the right to require the customer to make changes in the existing service facilities, including provisions for transformer facilities on the customer's premises.

Date: 10-31-25

GENERAL INFORMATION**3. INSUFFICIENT LOAD**

The Department will normally energize a customer's service when there is sufficient load to justify installation of the Department's facilities. When a customer requests the Department to supply service to a facility where the load is insufficient to justify the Department's investment, the customer will be required to reimburse the Department for the excess investment required to supply the load, or provide suitable, and mutually agreeable, guarantees that will warrant the Department's investment.

C. ELECTRIC LOADS (Cont.)**4. LOAD CHARACTERISTICS AFFECTING OTHER CUSTOMERS**

Where, in the Department's judgment, the characteristics of a customer's load may impair service to other customers, the Department may require that such loads to be supplied through a separate service, or that the customer supply suitable equipment, at the customer's expense, to reasonably limit voltage fluctuations caused by the equipment involved.

5. SINGLE-PHASE MOTORS

- a. Motors operated at 120 volts are limited to a maximum locked-rotor current of 46 amperes, or a full-load current of 12 amperes.
- b. Motors operated at more than 120 volts are limited to a maximum locked-rotor current not exceeding 450-percent of the full-load running current. Where more than one motor is installed in a device, the accumulated locked rotor currents shall be limited to 450-percent of the accumulated full-load running currents.

6. THREE-PHASE MOTORS

- a. The Department will generally supply three-phase service for motor loads totaling more than 5 horsepower (hp). While such installations are not generally limited to capacity either of individual motors, or of the entire installation, the Department may require that large motor loads be supplied from dedicated transformer facilities located on the customer's premises.
- b. Three-phase motors not exceeding 20 hp each and designed for "across-the-line" starting may be connected to the Department's electric system provided the starting demand does not exceed 6 kVA per rated horsepower.
- c. Three-phase motors in excess of 20 hp each and designed for "across-the-line" starting require the Department's approval before being connected to the Department's electric system. For each motor rated 40 hp and above, the following information must be provided to the Department:
 - (1) Rated horsepower and the motor use.
 - (2) Starting current by test or guaranteed locked-rotor current.
 - (3) Duty cycle (constant or intermittent), and the maximum number of starts per day.
 - (4) Number of motors started from a single controller.

7. LIGHTING

Gaseous tube lighting equipment or systems rated at 15 watts or more, and individual tube transformers rated at 150 volt-amperes or more and used with gaseous tube systems or signs, must be power factor corrected to 90-percent lagging or leading.

GENERAL INFORMATIONDate: 10-31-25

8. HEATING, COOKING AND MISCELLANEOUS LOADS

Single-phase commercial heating and cooking loads and other miscellaneous single-phase loads may, at the option of the Department, be supplied through a three-phase service at 240 volts. Customers must obtain approval from the Department if none of the individual loads is three-phase.

9. X-RAY UNITS OVER 5 KVA

Customers must obtain approval from the Department before installing x-ray equipment in units exceeding 5 kVA.

C. ELECTRIC LOADS (Cont.)**10. WELDERS**

a. Customers must obtain approval from the Department before installing welders:

- (1) Rated more than 3 kVA on any residential service.
- (2) Rated 15 kVA or more on any commercial or industrial service. Welders rated more than 15 kVA may require special serving facilities. Consult the Department for additional information.

b. Single-phase welders may be served through a three-phase service provided the loads are balanced. If the loads cannot be balanced, customers must consult the Department regarding the maximum allowable imbalance before service will be supplied. The two service entrance conductors supplying the greatest single-phase load shall be tagged, or otherwise identified, at the point of connection before service will be supplied.

11. ELECTRIC VEHICLE (EV) LOAD MANAGEMENT SYSTEMS

Equipment approved by the Authority Having Jurisdiction (AHJ) that automatically distributes available power capacity to multiple EV chargers in a way that does not overload an EV feeder circuit or utility service may be installed by the customer. The Department will consider up to 80% of such feeder capacity in determining if service is to be supplied from dedicated transformer facilities located on the customer's premises.

12. SPECIAL EQUIPMENT

Arc welding devices, x-ray machines, high-voltage testing and bombarding transformers, wireless telegraph or radio transmitting equipment, electric welders and furnaces, and other devices with similar load characteristics will be considered as special equipment and subject to Department Rules regulating connected loads and maximum demand.

Date: 10-01-25

GENERAL INFORMATION

D. INSPECTIONS**1. GENERAL**

- a. The Department will not energize any service or set any meter until the service and metering equipment, conduit, and other facilities required by the Department have been inspected and approved by the Department.
- b. The Department policy is to provide inspection of the customer's facilities in a timely manner and without causing unnecessary delays to the customer's construction schedule or service wanted date. However, it is the customer's responsibility to provide sufficient advance notice to the Department to avoid delays caused by conflicts with inspection schedules already committed.

2. SCHEDULING INSPECTIONS

- a. To schedule an inspection, contact the appropriate engineering office. Department construction drawings may specify a telephone number and email to contact for inspection.
- b. Contractors should notify the Department at the beginning of construction at the job site. In addition, contractors should request inspection as soon as facilities specified by the Department are ready for inspection.
- c. The following lead times are recommended when scheduling inspections:
 - (1) Service and metering equipment - 2 working days.
 - (2) Conduits and handholes - 2 working days.
 - (3) Vaults and pads - 5 working days.

Note: The Department's inspector is to be present while vaults and pads are being installed.

3. SPECIAL INSPECTIONS

- a. Inspections will normally be scheduled during the Department's regular working hours. Special inspections may be requested during overtime (premium) hours by contacting the appropriate engineering office at least two (2) working days in advance.
- b. The customer shall reimburse the Department for all premium time charges including travel time.

GENERAL INFORMATIONDate: 05-02-24

E. SERVICE VOLTAGES**1. CHARACTER OF SERVICE**

Service supplied throughout the Department's service territory is an alternating current at a regulated frequency of 60 cycles per second, and at the nominal voltages available from the Department's electric system.

2. SERVICE SUPPLY VOLTAGES**a. 120 VOLTS, SINGLE-PHASE, 2-WIRE**

This voltage is limited to a maximum service ampacity of 100 amperes.

b. 120/240 VOLTS, SINGLE-PHASE, 3-WIRE

- (1) This voltage is normally limited to a service ampacity of 600 amperes. Consult the Department when the proposed service exceeds 600 amperes.
- (2) The Department may require that large single-phase services be supplied from dedicated transformers located on the customer's premises with a three-phase, four-wire wye voltage. See items (e) and (f).

c. 240/120 VOLTS, 3-PHASE, 4-WIRE

- (1) This voltage supplies single-phase and three-phase loads through the same metered service and is normally limited to a service capacity of 800 amperes. Consult the Department when the proposed service exceeds 800 amperes.
- (2) The service neutral is center-tapped and grounded at the Department's transformer and the "Power Leg" measures 208 volts-to-ground.
- (3) Where service is supplied from dedicated transformers located on the customer's premises, the Department may require the service to be supplied with a four-wire wye voltage. See items (e) and (f).

d. 240 VOLTS, 3-PHASE, 3-WIRE

This voltage is generally not available for new services. New services may be permitted where an existing premises is already supplied at this voltage. However, the customer is required to consult the Department when planning increases in load or service ampacity to an existing service supplied at this voltage. Such changes may require conversion to a 4-wire service.

Note: Single-phase loads connected to a 3 \emptyset 3-wire service shall be reasonably balanced. The customer's system power factor (measured at the meter) shall not be less than 0.5 lagging.

e. 208Y/120 VOLTS, 1-PHASE, 3-WIRE AND 3-PHASE, 4-WIRE

- (1) This voltage is supplied from dedicated transformer installations located on the customer's premises and serves both single-phase and three-phase loads.

Date: 02-01-03

GENERAL INFORMATION

E. SERVICE VOLTAGES (Cont.)

- (2) Where load is insufficient to justify the Department's investment in on-site transformation, the customer will be required to reimburse the Department for the excess investment required to serve the load. Consult the Department's engineering offices for additional information.

f. 480Y/277 VOLTS, 3-PHASE, 4-WIRE

- (1) This voltage is supplied from dedicated transformer installations located on the customer's premises and serves both single-phase and three-phase loads.
- (2) Where load is insufficient to justify the Department's investment in on-site transformation, the customer will be required to reimburse the Department for the excess investment required to serve the load. Consult the Department's engineering offices for additional information.

g. 480 VOLTS, 3-PHASE, 3-WIRE

This voltage is generally not available for new services. New services may be permitted where an existing premises is already supplied at this voltage. However, the customer is required to consult the Department when planning increases in load or service ampacity to an existing service supplied at this voltage. Such changes may require conversion to a 4-wire service.

Note: Single-phase loads connected to a 3Ø 3-wire service shall be reasonably balanced. The customer's system power factor (measured at the meter) shall not be less than 0.5 lagging.

h. MEDIUM-VOLTAGE SERVICES

The Department generally supplies and meters services at 2400, 4160, and 4800 volts. Services will be supplied and metered at 34,500 volts, or other voltages specified by the Department, only when in the Department's judgment the size or special character of the load, or location, warrants such service.

3. ACCEPTABLE VOLTAGE RANGES

Under Normal conditions, the Department will generally maintain service supply voltages at the point of service within the following voltage ranges:

Nominal Voltage	Acceptable Voltages		Desirable Voltages	
	Minimum	Maximum	Minimum	Maximum
120	110	127	114	126
240	220	254	228	252
208	191	220	197	218
480	440	508	456	504

Note: The Department will not generally make adjustments for service supply voltage levels within the "acceptable" range. Voltage related problems may be reported by calling the Department's Electric Trouble Board - see page 1-7 for telephone numbers.

GENERAL INFORMATIONDate: 02-01-03

F. CLASSES OF SERVICE

1. Different classes of service are considered to have either different phase characteristics such as single-phase or three-phase, or different voltage characteristics such as 208Y/120 volts or 480Y/277 volts.
2. The Department will normally provide only a single voltage class of service, supplying all single-phase and three-phase loads, on the premises. Requests by customers to supply some loads on a premises at different voltage classes of service will be considered on an individual basis.

Date: 10-01-25

GENERAL INFORMATION

G. SHORT-CIRCUIT CURRENT, OVERCURRENT PROTECTION AND ARC FLASH POLICY

1. Permitting agencies require the installation of metering and service equipment with overcurrent protection at least equal to the available short-circuit current provided by the Department.
2. The Department's short circuit contribution is based on the maximum symmetrical short-circuit current available at the point of service, and will be provided as follows:

- a. Single-family residences, duplexes, and mobile homes supplied at 120/240 volts, 1 \emptyset 3-wire:

<u>Service Ampacity</u>	<u>Short-Circuit Current</u>
0-225 amperes	10,000 amperes
226-400 amperes	22,000 amperes

- b. Commercial or industrial services supplied at 480Y/277 volts, 3 \emptyset , 4-wire:

<u>Service Ampacity</u>	<u>Short-Circuit Current</u>
3000 amperes	55,000 amperes
4000-5000 amperes	72,000 amperes

Note: The maximum short-circuit duties specified above are guaranteed by the Department at the point of connection and a Short-Circuit (Fault) Report will be available online for review by the permitting agency. Field conditions likely to produce higher fault currents will be indicated to the customer by the Department.

- c. For all other services, short-circuit contributions will be calculated on an individual basis and a short-circuit report will be available online for review by the permitting agency. Short-circuit information may be obtained by contacting the appropriate Department engineering office - see page 1-4 for office locations and telephone numbers. Department generated short-circuit reports are available online at <http://wmisweb.ladwp.com/powerwmis/>.
3. **The customer is responsible for providing overcurrent protection equipment** such as circuit breakers, fusible switches, pull-out fuses, or other approved devices.
4. Fuses used for overcurrent protection:
 - a. Where fuses are installed by customers for overcurrent protection, the Department assumes no responsibility for their replacement.
 - b. Fuses, circuit breakers, or disconnects provided by the Department on its electric system shall not be used in place of a customer's fused service switch or breaker, and the Department assumes no responsibility for maintaining such devices for the protection of customer-owned wiring or electrical equipment.
 - c. **When entering a sealed enclosure to replace fuses**, call the Department's Electric Trouble Board and obtain permission to break the seals. See page 1-7 for telephone numbers.
5. In accordance with the Department's ARC Flash Determination and Short-Circuit Coordination Study policy, the Department will never provide system or equipment parameters such as transformer impedance or X/R ratios. Because of constant system changes over time, the Department is unable to supply accurate system or equipment parameters for these studies. Instead, the Department will only supply the maximum symmetrical short-circuit current available at the point of service.

GENERAL INFORMATIONDate: 05-02-24

H. TEMPORARY SERVICES**1. APPLICATION FEES AND CHARGES**

- a. The Department will supply electric service to installations of transitory character such as construction sites, bazaars, fairs, and circuses providing the customer pays in full all application fees and engineering charges associated with the installation and removal of Department facilities.
- b. An application fee will be charged for 120/240 volt, single-phase or three-phase services when limited to a maximum ampacity of 200 amperes, a maximum connected load of 10kW, and:
 - (1) Supplied from existing overhead facilities except for the installation of a single set of service drop conductors.
 - (2) Supplied from existing underground facilities except for the installation of a single set of service supply conductors to be used to serve the permanent load.

Note: Contact a customer service branch office or engineering office to determine the current application fees. See page 1-4 for office locations and telephone numbers.
- c. Additional engineering charges will be assessed for the installation and removal of transformers and other Department facilities required to supply temporary service.

2. PERMITS AND APPROVALS

- a. Customers must obtain approval from the Department for location and other details of the temporary service prior to installing the facilities. On completion, the conduit and electrical facilities must be inspected and approved by the Department.
- b. Customers must obtain the necessary permits from the inspection authority. Inspection must be completed by the inspection authority and the final electrical release received by the Department before the customer's temporary service will be energized.

3. TIME LIMITATIONS

The Department will generally limit the use of the temporary power to the period of construction, remodeling, maintenance, repair, or demolition of buildings or structures or similar activities. Temporary power installations serving decorative lighting, carnivals and similar purposes are generally limited to 90 days.

4. REMOVAL OF SERVICE

- a. The Department reserves the right to remove temporary power without notice when in the Department's judgment the service is no longer temporary in character, no longer used for the purpose for which the service was installed, not needed, or creates a hazardous condition.
- b. Requests for removal or "turn-off" will be accepted as an indication that service is no longer needed and any temporary facilities provided by the Department may be removed. Service can be transferred from the name of one customer to the name of a second customer provided the use location remains the same. Remove or turn-off orders may be made in person at one of the Department's customer service branch offices (See page 1-6 for locations), or by letter or telephone to:

Date: 10-31-18

GENERAL INFORMATION

H. TEMPORARY SERVICES (Cont.)

Los Angeles Department of Water and Power

Commercial Division
P.O. Box 111
Los Angeles, California 90051

Tel: (800) DIAL DWP or (213) 481-5411

5. INSTALLATION REQUIREMENTS

- a. For temporary services rated 200 amperes and below, see:
 - (1) Pages 7-22, 7-24 and 7-26 for overhead temporary service pole requirements.
 - (2) Page 5-22 for underground temporary service requirements.
- b. For temporary services exceeding 200 amperes, consult a Department engineering office for requirements. See page 1-4 for office locations and telephone numbers.

GENERAL INFORMATIONDate: 02-01-03

I. FLAT CONNECTED SERVICES**1. GENERAL**

- a. The Department recognizes that situations arise where a flat service or connection is necessary. In such cases, approval of both the Department and the inspection authority is required before making the flat connection.
- b. Flat connections may be approved for periods not to exceed seven (7) working days. If conditions require a flat connection for a longer period, customers are required to make arrangements for a metered temporary service.
- c. A flat connection may be requested by contacting the appropriate Department engineering office. See page 1-4 for locations and telephone numbers.

2. EMERGENCY FLAT CONNECTIONS

Flat connections of this type usually occur because of damage to customer's facilities such as those caused by fire. In such cases, where the flat connection is made by the Department, approval by the Department is assumed. Customers have seven (7) working days in which to repair the service or make arrangements for a metered temporary service.

3. BUILDING OR SERVICE ALTERATIONS

When it is necessary to remove a meter or a group of meters from service as a result of building or electric service alterations, a flat service may be requested. If a period longer than seven (7) working days is anticipated, or actually exceeded, customers must make arrangements for a metered temporary service.

J. CUSTOMER-OWNED GENERATORS

1. INTERCONNECTED GENERATORS

- a. Interconnected generators encompass any type of customer-owned generator or generating facility that can electrically parallel with, or potentially back feed into, the Department's electric system. Additionally, generators using a closed-transition ("make-before-break") type transfer switch or a multi-breaker transfer scheme, or an electrical inverter that can be configured to operate in a utility interactive mode constitute a potential back feed source into the Department's electric system and are classified as interactive generators. No interconnected generating system shall be switched or operated in parallel with the Department's electric system without the approval of the Department.
- b. All interconnected generating systems shall be connected on the load side of the customer's meter switch (main service disconnect device).
Exception: Some generating systems may be connected on the line side of the customer's disconnecting means as permitted by City, State or National Electric Codes, see **GENERATORS AND GENERATING SYSTEMS**, page 8-10.
- c. The Department has specific Interconnection Requirements that must be complied with for all interconnected generators. These include a visible open disconnect switch to isolate the Customer's system from the Department's system, as well as protective relaying, metering, special rate schedules, and other safety and information requirements. For additional information, see **DESIGN GUIDE FOR CUSTOMER-OWNED PARALLEL GENERATING SYSTEMS**, page 8-1.
- d. Anyone considering installing an interconnected generator should contact the Department for information. See **OFFICE LOCATIONS AND TELEPHONE ASSISTANCE**, page 1-3.

2. EMERGENCY OR STAND-BY GENERATORS

- a. Customer-owned emergency or standby generators shall be connected on the load side of the customer's meter switch (main service disconnect device) and shall normally be switched using double-throw switches, or automatic relays and switches, which isolate the load from the Department's electric system before the customer's generator is connected to the load - this switching arrangement is commonly referred to as open-transition or "break-before-make". When the Department's electric lines are re-energized, the customer's generator(s) shall be isolated from the load before the load is reconnected to the Department's electric system.
- b. **Customers with critical loads**, such as hospitals, that require periodic testing of their emergency or standby generating systems without interruption to their loads may use an automatic transfer switch that is capable of operating in both open and closed transition modes. For these types of transfer switches, if the period of parallel operation is less than one second, the owner must sign a Certification of Momentary Parallel Operation and Indemnification agreement. If the period of parallel operation is greater than one second, the operation is considered an interconnected generating system and the customer shall be required to provide a visible open disconnect switch to isolate the customer's electric system from the Department's electric system. **Customers shall not under any circumstances connect a closed transition transfer switch to the Department's electric system without the express permission of the Department or energize an un-energized Department electric line.**
Note: Closed-transition switches and programmable switches that can operate in either the open or closed transition modes shall be automatic rather than manually operated. Switches shall be certified by a Nationally Recognized Testing Laboratory to fully comply with low or medium voltage UL 1008 or UL 1008A standards for transfer switch equipment as applicable to grid safety.

GENERAL INFORMATIONDate: 05-02-24

J. CUSTOMER-OWNED GENERATORS (Cont.)

- c. Switching arrangements that require the customer to manually open the service disconnect switch in addition to operating the generator disconnect switch in order to isolate the customer's load from the Department's electric system are not acceptable.

Note: Keyed Interlock or padlock schemes that are combined with this switching arrangement are also not acceptable.

- d. Switching arrangements that include a special purpose relay that automatically operates the service disconnect and generator disconnect switches (Automatic Throw over) are allowed pending the Department's review and approval of the customer's operating scheme and equipment specifications. The customer shall also submit to the Department an Automatic Transfer Functionality Test Report indicating compliance with National standards for grid safety and appropriately field label any such equipment prior to connecting it to the Department's distribution system. Regardless of transition mode, the Customer shall submit to the Department a signed Certification of Momentary Parallel Operation and Indemnification agreement.
- e. **Portable generators are not designed or intended to be connected to a building's permanent wiring system**, and shall not be connected to any such wiring unless a permanent and approved open-transition transfer switch is used. Failure to use a transfer switch can result in a back feed through a Department-owned transformer and be stepped up to a very high voltage. This can pose a potentially fatal shock hazard to anyone working on or near power lines.

3. STAND-ALONE GENERATING SYSTEMS

Stand-alone generating systems shall not be installed or operated without the approval of the Department.

Date: 10-01-25

GENERAL INFORMATION

K. TRANSFORMER INSTALLATIONS ON THE CUSTOMER'S PREMISES**1. GENERAL**

- a. The Department reserves the right to supply electric service by means of transformer installations located on the customer's premises when:
 - (1) The primary voltage of the Department transformer is supplied at 34,500 volts or greater.
 - (2) The service is supplied at 208Y/120 volts.
 - (3) The service is supplied at 120/240 volts:
 - (a) Single-phase and the transformer required to serve the load is 167 kVA or greater.
 - (b) Three-phase and the transformer(s) required to serve the load is 300 kVA or greater.

Note: The Department may require large single-phase services, or services with three-phase load requirements to be supplied from a three-phase, four-wire wye voltage.

 - (4) The service is supplied at 480Y/277 volts.
 - (5) The service is supplied at 2400, 4160 or 4800 volts.
 - (6) Required for the Department's operating convenience or necessity.
- b. The Department will determine whether the transformer facilities are supplied from the 4800-volt electric system or the 34,500-volt electric system. Transformer installations will generally be supplied from the 34,500-volt system when the customer's estimated load exceeds 500 kVA.
- c. All facilities specified by the Department and installed by the customer must comply with the requirements specified by the Department as well as applicable Federal and State laws, municipal regulations and codes of the City of Los Angeles, and regulations of other public bodies or agencies having jurisdiction.
- d. Transformer facilities required by the Department to be located on a customer's premises shall be dedicated to, and serve only, those loads on the premises on which the transformer facility is located. This restriction does not apply to the Department's distribution transformers installed on poles or in underground structures and located on Department easements or right-of-ways on the customer's premises.

2. TRANSFORMER INSTALLATIONS

- a. The type of transformer installation shall be determined by the Department with consideration being given to the customer's service size, demand load, suitability for the particular application, and the Department's operating needs.
- b. The following types of transformer installations are generally available from the Department:
 - (1) **POLE-MOUNTED TRANSFORMER INSTALLATIONS**
 - (a) This installation is available only in areas served from overhead distribution lines and when approved by the Department. The pole or pole rack will be furnished and installed by the Department at the Customer's expense.

GENERAL INFORMATIONDate: 10-01-25

K. TRANSFORMER INSTALLATIONS ON THE CUSTOMER'S PREMISES (Cont.)

- (b) The pole or pole rack shall be installed in a location that is agreeable to both the Department and the customer. Poles shall not be located less than 10 feet from any property line, building, building overhang, or other location accessible to human contact unless suitable safe-guards are provided by the customer, and agreed to by the Department, to prevent contact with energized facilities.
- (c) An easement or right-of-way will be furnished by the customer at no cost to the Department.
- (d) Service supply voltages exceeding 600 volts and supplied from poles will normally be served underground.

(2) PADMOUNT TRANSFORMER INSTALLATIONS

Approved concrete pads or precast slab boxes shall be furnished, installed, and maintained by the customer at the customer's cost. Padmount locations shall comply with the Department requirements, and must be approved by the Department before installation.

(3) UNDERGROUND VAULT TRANSFORMER INSTALLATIONS

Approved precast vaults shall be furnished, installed, and maintained by the customer at the customer's cost. Vault locations shall comply with Department requirements, and must be approved by the Department before installation.

(4) OUTDOOR TRANSFORMER INSTALLATIONS

- (a) Customers shall furnish and maintain, at the customer's cost, an approved concrete pad of sufficient strength to support transformers and related equipment. The pad shall be lighted, and provided with a fenced enclosure constructed of galvanized chain link, concrete block, or other approved materials.
- (b) Enclosure dimensions, together with provisions for access, drainage, ventilation, and lighting if required, as well as other details shall be in accordance with specifications furnished by the Department.
- (c) The Enclosure shall be for the exclusive use of the Department. No part of the enclosure shall be used for the customer's service equipment, storage, or for access to other equipment. Ducts, pipes, or conduits not specified for the installation shall not be installed in or under the fenced enclosure.
- (d) Consult with the Customer Station Design Group regarding their installation requirements. For the office location and telephone numbers, see page 1-4.

(5) INDOOR TRANSFORMER INSTALLATIONS

- (a) Customers shall furnish and maintain, at the customer's cost, an approved transformer room. The room may be located in a building either above or below grade.
- (b) Room dimensions, together with provisions for access, ventilation, weatherproofing, and lighting, as well as other details, shall be in accordance with specifications furnished by the Department.

Date: 10-01-25

GENERAL INFORMATION**K. TRANSFORMER INSTALLATIONS ON THE CUSTOMER'S PREMISES (Cont.)**

- (c) The room shall be for the exclusive use of the Department. No part of the room may be used for the customer's service equipment, storage, or for access to other equipment. Ducts, sprinklers, pipes, or conduits not specified for the installation shall not be installed in, under, or through the room except where specifically permitted by the Department.
- (d) Consult with the Customer Station Design Group regarding their installation requirements. For the office location and telephone numbers, see page 1-4.

3. STANDARD INSTALLATIONS

- a. Standard installations consist of transformers and related facilities that are the most cost effective for the Department. Except where otherwise specified, standard installations are generally pole-mounted or padmounted transformer facilities.
- b. Pole-mounted transformer installations are not permitted in areas designated by the Department as underground distribution districts.

4. CHARGES FOR NONSTANDARD INSTALLATIONS

Where a nonstandard transformer installation is requested by the customer, or is required as a result of the customer's onsite construction or load requirements, the customer shall pay the Department, in advance, the estimated cost of the added facilities exceeding an equivalent standard installation. Consult the Department regarding the current charges for nonstandard installations.

5. ACCESS AND CLEARANCES

- a. The customer shall provide adequate space, without cost to the Department, for the transformers and other necessary facilities required to provide electric service.
- b. Space provisions, as specified by the Department, shall provide for the required clearances between the Department's facilities and adjacent structures and shall include adequate provisions for ingress to and egress from these facilities by Department personnel and access for Department trucks and cranes required for the installation and replacement of these facilities

GENERAL INFORMATIONDate: 10-31-18

K. TRANSFORMER INSTALLATIONS ON THE CUSTOMER'S PREMISES (Cont.)**6. CUSTOMER STATIONS****a. GENERAL**

- (1) In transformer installations supplied from the Department's 34,500-volt electric system, and indoor or enclosed outdoor transformer installations supplied from the Department's 4800-volt electric system are classified as Customer Stations.
- (2) Customer Stations supplied from the 34,500-volt electric system are termed Industrial Stations (I. S.) and indoor or enclosed outdoor, transformer installations supplied from the 4800-volt electric system are termed Commercial Stations (C. S.).
- (3) Consult with the Customer Station Design Group regarding installation requirements. For the office location and telephone numbers, see page 1-4.
- (4) The Department will furnish and install:
 - (a) All electrical equipment at, or in, the installation except for equipment which is provided by the customer as specified in the Department's customer requirement drawings.
 - (b) Conductors supplying the primary side of the Department-owned transformers and secondary distribution conductors to supply points.
 - (c) Service supply conductors from the Department-owned transformer, or supply point, to the point of service.
- (5) The customer shall furnish and install all facilities specified by the Department on the Customer requirement drawings, including:
 - (a) Cable bus structures from the terminating room or enclosure to the service terminating enclosure when required or approved for use by the customer station design engineer. The Department will furnish and supply the conductors.
 - (b) Busway service (bus duct) from the transformer room or enclosure to the point of service when approved for use by the customer station design engineer. The bus duct will be owned and maintained by the customer at the customer's cost.

b. REDESIGNS AND CANCELLATIONS

- (1) The Department will provide the design for customer station installations. Should it become necessary to redesign the customer station facilities for the customer's convenience, the customer will be required to reimburse the Department for the cost of the previous design before a new design will be provided.
- (2) Should a customer cancel a project after completion of the Department's design, the customer will be required to reimburse the Department for the cost of the completed design.

c. INSUFFICIENT LOAD

The Department will normally energize a customer's service when there is sufficient load to justify installation of the department's facilities. When a customer requests that the permanent Department facilities be energized without sufficient load, the customer will be charged for the cost of the Department's excess design.

Date: 05-02-24

GENERAL INFORMATION

K. TRANSFORMER INSTALLATIONS ON THE CUSTOMER'S PREMISES (Cont.)**d. SCHEDULED MAINTENANCE/STANDBY GENERATORS**

- (3) Customer station installations involving indoor transformer rooms, roof-top mounted transformers, or enclosed (fenced) transformers require periodic outages so that the Department can service and maintain Department-owned equipment, and the customer can service and maintain customer-owned equipment.
- (4) Customer outages will generally last six hours or more. However, the Department will make every effort to complete servicing and maintenance of Department facilities in a reasonable time.
- (5) When a customer requires the premises to have a continuous electric service, the customer shall be responsible for providing, at the customer's cost, standby generators or other equipment necessary to continue service while the Department-owned and customer-owned facilities are serviced and maintained. For additional information regarding customer-owned generators, see page 1-32.

L. FIRE PUMP SERVICE

1. A fire pump(s) may be served by a dedicated meter, meter and service, or a house meter with a line side tap.
2. When a fire pump(s) is served from a house meter, line side taps may be made between the load side of the house meter and the line side of the of the service main disconnect, provided:
 - a. A sign is provided at the tap point with a map of the building showing the location of the fire pump(s) automatic transfer switch (ATS), controller(s) or combination thereof.
 - b. The customer provides an ATS, fire pump controller(s) or combination that is service entrance rated.
 - c. The customer's switchgear has provisions for making a line side tap that has been both certified by a Nationally Recognized Testing Laboratory (NRTL) and has the approval of the Authority Having Jurisdiction (AHJ).
3. Except for heating elements and associated wiring specified and supplied by the manufacturer, no other wiring or customer owned devices shall be installed in or routed through any utility sealed section.
4. Customer owned surge-arrestors or suppressors shall not be installed on the line side of an ATS or fire pump(s) controller(s) service disconnect switch.

Exception: The customer provides an additional service rated disconnect switch on the line side of any customer owned surge-arrestor or suppressor.
5. The metering equipment size and rating shall match the fire pump source requirements as approved by the AHJ.

M. PARALLEL CONNECTION OF UTILITY SOURCES (Double-Ended Switchboards)

Whenever multiple utility sources served from a common supply point and of the same service class share a switchgear bus (double-ended), the customer shall install, with Department approval, a key interlock system to prevent the parallel connection of separate utility sources (Main-Tie-Main breaker arrangement).

Exception: An automated throw-over, open-transition scheme may be used with Department approval, see page 1-32.

Note: Additional locking provisions are required for service disconnects, see pages 3-7 and 4-3.

GENERAL INFORMATIONDate: 10-01-25

N. CUSTOMER-OWNED INSTRUMENT TRANSFORMERS AND PROTECTIVE DEVICES

1. Except for heating elements and associated wiring specified and supplied by the manufacturer no other wiring or devices shall be installed in or routed through utility sealed sections.
2. All customer-owned devices shall be connected to the load side of the meter.
3. All customer-owned devices shall be connected to the load side of the service disconnect.

Exception: Customer-owned surge-arrestors or suppressors, breaker control power transformers (CPT), instrument transformers and arc flash equipment may be connected to the line side of the customer's service disconnect provided:

- a. The device is necessary for switchboard or switchgear protection.
- b. The customer furnishes a front accessible service rated breaker, disconnect switch or rack-out drawer that disconnects the entire device load and can be locked in the open position.
Note: Removable fuses or links are not acceptable as a means of disconnect.
- c. All devices have overcurrent protection.
- d. The customer furnishes a label for each device disconnecting means indicating the device name and function, and reading "Open for Test". For example:

"CPT1"

"Control Power Transformer - Disconnect number 1 of _"

"Open for Test"

- e. Cold Sequence devices will require power consumption measured by the house meter.
 - f. Hot Sequence devices will require power consumption measured by their respective meters.
4. References:
 - a. For additional manufacturer labeling requirements, see pages 2-10, 3-11 and 4-3.
 - b. Service Disconnects, see pages 2-6, 3-7 and 4-3.

O. SCHEDULING OUTAGES

Outages for customer maintenance, repairs, upgrades or modifications will normally be scheduled by the Department during regular working hours. However, customers may request the Department to de-energize the electric service during premium (overtime) hours for the convenience of the customer. Requests for premium time maintenance or repairs may be made by contacting the Customer Service 24 Hour phone number, see page 1-6. For upgrades or modifications, contact the appropriate Engineering office, see page 1-4. Customers may be required to reimburse the Department for all personnel standby, safety observers and premium time charges. Due to current workload and resources, required outage lead-time may vary.

Note: Depending on nature of work, equipment changes and upgrades may require ESR and AHJ releases before service can be restored.

P. CERTIFICATION OF METER AND SERVICE EQUIPMENT

All meter and service equipment shall be certified (listed) and labeled by a nationally recognized testing laboratory (NRTL) for the appropriate type and class as recognized by the Los Angeles Department of Building and Safety (LADBS), refer to the most current list posted on the LADBS website. All equipment modifications shall require an NRTL field evaluation and report with appropriate label.

Q. LABELING OF METER AND SERVICE EQUIPMENT (Customer)

All meter and service equipment shall be clearly and permanently labeled with the service address, voltage, phase and ampacity with a minimum of 3/8" lettering, unless otherwise specified by the Department.

Note: When a service installation does not serve an entire building, the installation shall be permanently marked to indicate the portion of the premises served.

Date: 10-01-25

GENERAL INFORMATION

R. ADJUSTABLE/PROGRAMMABLE BREAKERS

In the case that adjustable/programmable breakers are to be used, the following requirements must be met:

1. Switchboard/gear submittals along with the single-line diagram will need to indicate which breakers are adjustable, the operable range of the breakers, and what value(s) to which the breaker will be designated for the service.
2. Protective features, including trip settings, cannot rely on an external source to maintain their settings (e.g., a battery). The breakers must not require reprogramming of their protective scheme in case an outage takes place.
3. If the breaker can exceed the approved ampacity:
 - a. Signage shall be provided for the breaker, stating the approved ampacity for the designated breaker, and:
 - i. The sign will be weatherproof placed on the switchboard with epoxy seals.
 - ii. The label for each breaker will state:
"Breaker for _(Unit(s) or Switchboard) Approved for only _ A"
 - b. A seal covering that covers the area that calibrates the ampacity of the breaker shall be required.
 - i. Further, any portions of the breakers requiring periodic maintenance, (e.g., replacing batteries), or other dials used for maintenance on the breakers, will require an opening in the sealed area such that access can be achieved **without breaking the utility seal**.
 - ii. Inspections and approval of the breakers will require the presence of both a DBS representative and the ESR, at the same time, and both will need to grant their approvals at that time for such breakers to pass inspection which will result in the ESR placing a seal immediately after the passed inspection with the DBS representative present. **It is the customer's responsibility to coordinate for this inspection.**

SERVICE AND METERING EQUIPMENT, 0 - 600 VOLTSDate: 01-01-10

CONTENTS

	<u>PAGE</u>
A. Meter Sockets	2-3
1. General	2-3
2. Residential Services	2-4
3. Commercial and Industrial Services	2-4
4. Meter Socket Jaw Arrangements	2-5
5. Meter Connections and Wiring	2-6
6. Customer-Owned Protective Devices	2-6
B. Meter Panels	2-6
C. Service Disconnects	2-6
1. Meter Switches	2-6
a. General	2-6
b. Rating	2-6
2. Service Main Switches for Multiple Metering	2-7
a. General	2-7
b. Locking Provisions	2-7
D. Meter Sequence	2-7
E. Underground Service Termination Pull Boxes	2-8
1. General	2-8
2. Location and Working Space	2-8
3. Cover Panels	2-8
F. Lifting Handles	2-9
G. Sealing Requirements	2-9
H. Grounding and Bonding	2-9
I. Labeling Requirements	2-10
Illustrations:	
Cable Terminating Facilities in Pull Boxes and Pull Sections	2-12
Underground Pull Box without Terminating Facilities	2-15
Underground Pull Box with Cable Terminating Facilities	2-16
Combination Pull Box and Service Main Disconnect for Residential Multiple-Meter Services	2-18
Combination Pull Box and Meter Socket with Service Disconnect for Single-Family Residential Services, 225 Amperes Maximum	2-20
Combination Pull Box and Meter Socket with Service Disconnect for Single-Family Residential Services, 400 Amperes (Class 320)	2-22
Typical Pull Box Arrangements for Residential Multiple-Meter Installations (6 Meters Maximum)	2-24
Safety-Socket Meter Panel, 100 and 200 Amperes	2-26
Safety-Socket Meter Panel with Service Disconnect, 100 and 200 Amperes	2-28
Test-Bypass Blocks for Safety Sockets, 100 and 200 Ampere	2-32

CONTENTS (Cont.)

	<u>PAGE</u>
Meter Socket Panel With Test Switch Mounting Plate for Instrument-Transformer Metering Installations	2-34
Current-transformer Box with Meter Socket Panel for Underground Service, 400 Amperes	2-36
Current-transformer Box with Meter Socket Panel for Overhead Service, 400-800 Amperes	2-38
Current-Transformer Mounting Bases, 800 Amperes Maximum:	
1Ø 3-Wire and 3Ø 3-Wire	2-40
1Ø 3-Wire and 3Ø 3-Wire (Overhead Supply)	2-41
3Ø 4-Wire	2-42
3Ø 4-Wire (Overhead Supply)	2-43
Service and Meter Pedestal for Commercial Services	2-44
Service and Meter Post for Mobile Home (Trailer) Services	2-48

A. METER SOCKETS**1. GENERAL**

- a. Each customer shall be permitted to have only a single meter socket for each voltage and phase to be metered. Sockets shall have the jaw arrangement specified for the voltage and phase to be metered and an approved sealing ring. See page 2-5 for socket jaw arrangements.
- b. For commercial and industrial multi-meter installations, no more than two meters shall be mounted on a single removable panel unless the design permits replacement of individual meter sockets without disturbing adjacent meters secured with sealing or locking rings.
- c. For residential multi-meter installations, no more than one meter shall be mounted on a single removable panel unless the design permits replacement of individual meter sockets without disturbing adjacent meters secured with sealing or locking rings.
- d. Whenever a single meter registers the current supplied to more than one residential occupancy, the installation shall be considered a commercial installation for the purposes of these requirements unless otherwise approved by the Department.
- e. Meter sockets shall be designed in accordance with the latest revision of AEIC-IEEE-NEMA Standards for Watt-hour Meter Sockets (ANSI C12.7) and Underwriters Laboratories (UL) Standard for Meter Sockets (UL414). The socket rim to socket jaw clearance shall not be less than specified by ANSI C12.7 (0.500 inch) or more than 0.690 inch.
Exception: The 0.690-inch dimension does not apply to transformer rated sockets or to ground or neutral jaws of self-contained sockets.
- f. Self-contained meter sockets shall be attached to the back wall of the socket enclosure or to a stationary support connected to the enclosure, and attached to the meter panel to assure alignment of the socket ring to the socket jaws and to prevent removal of the panel with the meter installed.
- g. Instrument-transformer rated meter sockets shall be designed for back connection when installed on hinged panels and for front connection when installed on non-hinged panels. Sockets shall be installed with machine screws so the socket can be easily interchanged or replaced.
Note: Screws used to mount cast meter sockets to meter panels shall provide a 1/8" minimum clearance between the screw head and the back of the meter socket ring.
- h. Meter socket wire terminals shall be sized to accept wires without removing wire strands and shall not be accessible with the meter installed.
- i. Meter sockets may be either surface-mounted or semi-flush mounted.
- j. All meter fittings shall be mounted on a substantial support in a true vertical position.
- k. Meter sockets and test-bypass compartments shall be barriered from customer sections.
- l. Meter sockets and installations not permitted:
 - (1) Ringless or gasketed type meter sockets.
 - (2) Lever bypass meter sockets.
 - (3) Fully plastered-in meter socket boxes.
- m. Meter sockets in multi-meter installations shall be clearly and permanently identified with the address it serves, as specified by the Department.

A. METER SOCKETS (Cont.)**2. RESIDENTIAL SERVICES**

- a. For residential self-contained metering applications, meter sockets shall have a maximum ampacity rating that is less than the ampacity rating of the associated meter switch. The maximum ampacity rating is 125% of the continuous-duty rating.
- b. When the meter switch exceeds 225 amperes, but does not exceed 400 amperes, a self-contained meter panel (class 320), current-transformer box, or switchboard service section shall be installed.

3. COMMERCIAL AND INDUSTRIAL SERVICES

- a. For commercial and industrial applications, meter sockets shall have a continuous-duty rating of 100 amperes for meter switches rated up to 125 amperes (maximum) and a continuous-duty rating of 200 amperes for meter switches rated up to 250 amperes (maximum).
- b. A standard (100 ampere) safety-socket box is required for installations where the maximum rating of the meter switch does not exceed 125 amperes. The following exceptions permit the use of a residential meter socket (i.e., meter socket without test-bypass blocks):
 - (1) Single-phase house lighting services in multiple-occupancy residential buildings where the house service does not supply fire alarms or motor-driven equipment.
 - (2) Single-phase signboard services not having motor-driven equipment.
 - (3) Single-phase temporary services.

Note: Contractors should verify the Department's short-circuit contribution before installing a combination meter/main residential panel for any temporary service.
 - (4) Single-phase cathodic protection services.
 - (5) Single-phase parking lot lighting or area lighting services.
 - (6) Single-phase CATV and similar services where the customer provides a backup power supply with automatic switching. The Department shall not be responsible for notifying the customer of scheduled meter tests or similar activities that require removal of the meter from the socket.
 - (7) Single-phase statistical meter socket for electric vehicle chargers.

Note: The exceptions above do not apply to 277-volt single-phase.
- c. A heavy-duty (200 ampere) safety-socket box is required for installations where the maximum rating of the meter switch exceeds 125 amperes, but does not exceed 250 amperes. See item 3b(6) above for exception.
- d. Where the maximum rating of the meter switch exceeds 250 amperes, a current-transformer box or a switchboard service section with an instrument-transformer compartment is required.

A. METER SOCKETS (Cont.)

4. METER SOCKET JAW ARRANGEMENTS

METERED VOLTAGE	NUMBER OF SOCKET CLIPS	
	SELF-CONTAINED SOCKETS	TRANSFORMER-RATED SOCKETS
1-PHASE		
120/240-VOLTS 3-WIRE	4	6
120-VOLTS 2-WIRE	4	N/A
120/208-VOLTS 3-WIRE	5	N/A
480-VOLTS 2-WIRE	4	N/A
3-PHASE		
240/120-VOLTS 4-WIRE	7	13 or 15
240-VOLTS 3-WIRE (see note)	5	8 or 15
208Y/120-VOLTS 4-WIRE	7	13 or 15
480Y/277-VOLTS 4-WIRE	7	13 or 15
480-VOLTS 3-WIRE (see note)	5	8 or 15
2400-VOLTS 3-WIRE	N/A	8 or 15
4160-VOLTS 3-WIRE	N/A	8 or 15
4800-VOLTS 3-WIRE	N/A	8 or 15
34,500-VOLTS 3-WIRE	N/A	8 or 15

Note: For information regarding the availability of the metered voltage, see **SERVICE SUPPLY VOLTAGES**, page 1-25.

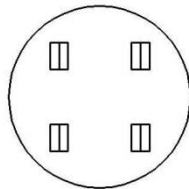

4-CLIP
FIG. 1

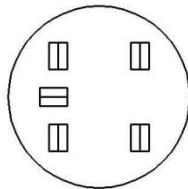

5-CLIP
FIG. 2

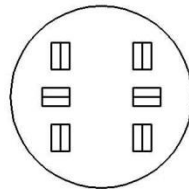

6-CLIP
FIG. 3

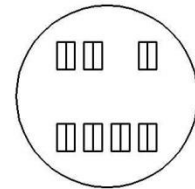

7-CLIP
FIG. 4

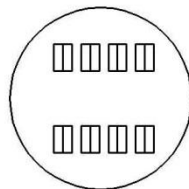

8-CLIP
FIG. 5

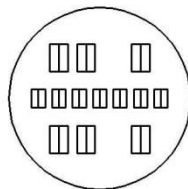

13-CLIP
FIG. 6

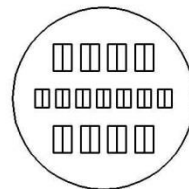

15-CLIP
FIG. 7

Date: 05-02-24

SERVICE AND METERING EQUIPMENT, 0 - 600 VOLTS

A. METER SOCKETS (Cont.)**5. METER CONNECTIONS AND WIRING**

- a. The customer shall connect the conductors to the terminals in the socket for all self-contained meter installations except where the meter sockets are wired by the factory.
- b. The customer shall not connect any conductor to the socket terminals for any instrument-transformer rated meter installation.
- c. Meter-socket boxes and current-transformer boxes shall not be used as pull or junction boxes except as specifically permitted in these requirements. Connections shall not be made in any of these boxes to supply any other meter.

6. CUSTOMER-OWNED DEVICES

Customer-owned adapters, automatic or manual transfer switches, surge-arrestors, fuses, breakers or other devices shall not be installed between the meter socket and the Department's electric meter.

B. METER PANELS

1. **For residential services**, no more than one meter socket shall be mounted on any removable panel unless the design permits replacement of individual meter sockets without disturbing adjacent meters sealed with security locking rings.
2. **For commercial or industrial services**, no more than two meter sockets shall be mounted on any removable panel unless the design permits replacement of individual meter sockets without disturbing adjacent meters sealed with security locking rings.

C. SERVICE DISCONNECTS**1. METER SWITCHES****a. GENERAL**

- (1) The customer shall furnish and install a service disconnect device (meter switch) such as a circuit breaker, fused switch, or other approved disconnecting device with overcurrent protection on the load side of the meter (HOT SEQUENCE).
- (2) The meter switch shall control all of, and only, the energy registered by the meter.
- (3) When approved by the AHJ, the meter switch may consist of a group of up to six separate disconnect devices grouped at a single location. See "Rating" below.
- (4) The meter switch shall be fully accessible and located directly adjacent to its associated meter unless otherwise approved by the Department.

Note: For single family residences and duplexes, the meter switch shall also be located outdoors.

b. RATING

- (1) When a group of service disconnect devices are used in place of a single meter switch, the ampacity rating of the bus or maximum size conductors allowable in the service wiring raceway will be considered the ampacity rating of an "equivalent" meter switch.
- (2) When more than one meter socket is supplied from a bussed gutter and a group of service disconnect devices is used in place of a single meter switch, the ampacity rating of the meter loop conductors will be considered the ampacity rating of an "equivalent" meter switch.

C. SERVICE DISCONNECTS (Cont.)**2. SERVICE MAIN SWITCHES FOR MULTIPLE METERING****a. GENERAL**

- (1) A service main disconnect device shall consist of either a circuit breaker, fused disconnect or other approved disconnecting means located on the line side (COLD SEQUENCE) of its group of related meters.

Note: A main service switch shall not be installed on the line side of a single meter socket.

- (2) Auxiliary equipment related to the service main switch shall be fully located within the switch cabinet or compartment and only equipment required by the AHJ for Code compliance shall be approved. The devices will need to be barriered such that they are not contained in the utility sealed section and maintenance can be done without needing to open the utility sealed section. Power supplies for auxiliary equipment shall be fed from a metered source.
- (3) A service main switch shall be located in a meter room or meter area, unless otherwise approved by the Department.

b. LOCKING PROVISIONS

The service main shall be required to be lockable in the open (off) position when:

- (1) The switch is not adjacent to its related group of meters (i.e., adjacent means within reasonable proximity and sight of each other), or
- (2) Otherwise specified by the Department's service planner.

D. METER SEQUENCE

1. Every single meter socket shall be installed on the line side of its related meter switch (HOT SEQUENCE).
2. For multiple meter installations where a service main switch is required or permitted on the line side of the meter sockets (COLD SEQUENCE), the switch shall be located adjacent to its related meter sockets.

Exception: For large multi-story buildings or other installations where the Department has approved meters in multiple or remote locations and the Permitting Authority has required a (controlling) service disconnect device at the source location to protect the service entrance conductors, the adjacent disconnect device at the remote meter location is not required provided:

- a. The meter switch or service main switch for the metering equipment shall control all electric load to a specific area and is labeled to indicate the controlled area (i.e., occupancy, load served, etc.)
 - b. The metering equipment is located in a publicly accessible area and is labeled to clearly identify the controlling service switch and its location.
 - c. The controlling service switch is capable of being locked in the open position.
3. To prevent energy diversion, unmetered runs of service entrance conductors supplying remote meter location shall be enclosed in an unbroken conduit run. The Department reserves the right to inspect these conduit runs during and subsequent to the installation.

Exception: Pull boxes, condulets and LB condulets when required by the permitting agency for cable support or pulling needs shall be installed in meter rooms, sealable, clearly identified and readily accessible. Lifting handles shall be provided where required. Condulets and LB condulets installed in other locations require approval of the Department prior to installation.

E. UNDERGROUND SERVICE TERMINATION PULL BOXES

1. GENERAL

- a. Underground service supply conduits installed from the Department's underground electric system (or pole dips from the overhead electric system) to the customer's metering equipment shall terminate in an approved underground terminating enclosure. For approved pull box arrangements, see pages 2-15, 2-16, 2-17, 2-18, 2-20, 2-22, 2-24, 2-36, 2-38, 2-44 and 2-48. For approved pull section arrangements, see pages 3-44 and 3-46.

CAUTION: Service supply conduits shall not enter any terminating enclosure above either the cable terminating facilities or other energized bussing.

- b. Except for the Department's service supply conductors and the customer's service entrance conductors, no other conductors or devices (i.e., fuses, cable limiters, surge arrestors, current-transformers and other customer-owned wiring or devices) shall be installed in, or routed through, any underground pull box enclosure.
- c. When any change is made in the services supplied from an existing terminating pull box, the pull box must meet these requirements.
- d. Pull box covers shall be sealable, provided with lifting handles and not exceed a maximum of 9 square feet in area with a maximum width or length of 5 feet.

2. LOCATION AND WORKING SPACE

- a. The service terminating pull box shall be:
 - (1) Readily accessible and located on the exterior wall of a building or other approved permanent structure, in an approved meter room on the first or basement parking level or such other locations as the Department may designate.
 - (2) Provided with a level, unobstructed working space in front of the entire pull box. The minimum required working space shall be 3 feet in width, extend 3 feet from the front of the pull box, and extend to the top of the pull box, but not less than 6 feet - 6 inches.
- b. Pull box locations prohibited:
 - (1) In any meter room, storage room, basement area or enclosed patio in a single-family dwelling.

Note: Pull boxes shall be accessible without entering the building.
 - (2) In any occupancy in a multi-tenant building.
 - (3) In any rest, bath, shower, or toilet room or in any room accessed through such areas.
 - (4) In any hazardous location as determined by the Department.
 - (5) In any other area determined to be unacceptable by the Department.

3. COVER PANELS

Pull box covers shall be sealable, provided with lifting handles, and not exceed a maximum of 9 square feet in area with a maximum length or width of 5 feet.

F. LIFTING HANDLES

1. Removable cover panels shall be equipped with a lifting handle located so as to provide control and balance while the panel is being removed.

Note: Cover panels in excess of 3 square feet shall require two lifting handles.

2. Hinged panels shall be equipped with a handle on the side opposite the hinges.
3. Handles shall be sized for full hand grasping, be securely attached to the panel and be able to withstand handling stresses of not less than 75 pounds. Folding or hinged handles are not acceptable.

G. SEALING REQUIREMENTS

1. Sealable latches, captive stud assemblies, or sealing screws may be used for sealing and shall be installed so as to prevent a sealed cover from being opened or removed without breaking the seal.
2. Non-hinged removable covers shall be sealed with captive stud assemblies on opposite sides of the cover. Alternate sealing methods may be used if the removable cover is self-supporting with the securing screws and sealing provisions removed.
3. Hinged covers or panels shall be sealed on the side opposite the hinges.
4. Captive stud assemblies shall consist of a 1/4-inch - 20 (minimum) stud, and associated wing-nut, each drilled 0.0635 inch (minimum) for sealing purposes. The stud shall be securely attached so as to not loosen or back out when being fastened.

H. GROUNDING AND BONDING**1. GROUNDING**

- a. Manufacturers shall not provide a terminal lug for the customer's grounding conductor in any compartment sealed or locked by the Department.

Exceptions: A grounding terminal is permitted in a main service switch compartment or, when required by the permitting agency for services supplied from overhead, in a sealed wireway used to supply more than one meter socket.

- b. The grounding electrode conductor shall not be installed in, or routed through, any compartment sealed or locked by the Department.

2. BONDING

- a. Ground bus units installed by manufacturers to provide bonding between equipment sections are permitted in compartments sealed or locked by the Department. See item 1 under "Grounding" regarding placement of the terminal lug for the customer's grounding conductor.
- b. Conduit bonding jumpers shall be terminated at the closest practical point from where the conduit to be bonded enters the underground terminating enclosure or metering compartment.

Date: 12-01-24

SERVICE AND METERING EQUIPMENT, 0 - 600 VOLTS

I. LABELING REQUIREMENTS (Manufacturer)

1. Meter and service equipment shall be provided with a manufacturer's label identifying the metered voltage, phase, ampacity and rated short-circuit duty (when applicable).
2. Meter and service equipment shall be provided with a label identifying the nationally recognized testing laboratory (NRTL) that has tested and listed the equipment.
3. Multi-voltage rated service and metering equipment shall be identified with the metered voltage.

**THIS PAGE LEFT
INTENTIONALLY BLANK**

CABLE TERMINATING FACILITIES IN PULL BOXES AND PULL SECTIONS

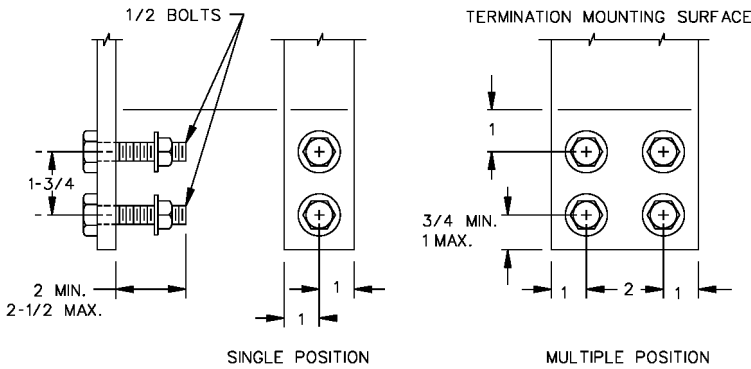

SINGLE POSITION
MULTIPLE POSITION
TERMINATING FACILITIES
FIGURE 1

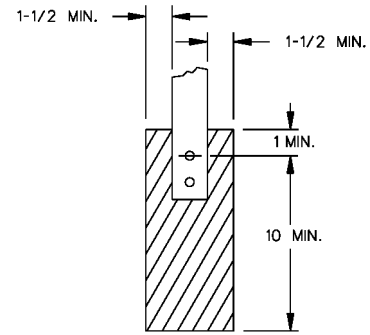
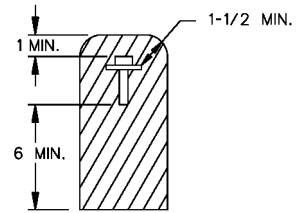

UNOBSTRUCTED SPACE IN THE
TERMINATION MOUNTING AREA
SEE NOTES 7 AND 8
FIGURE 2

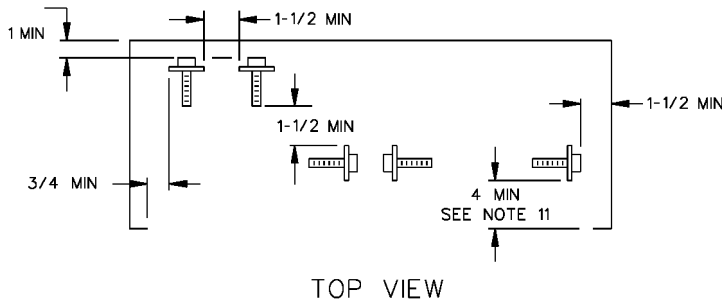

TOP VIEW

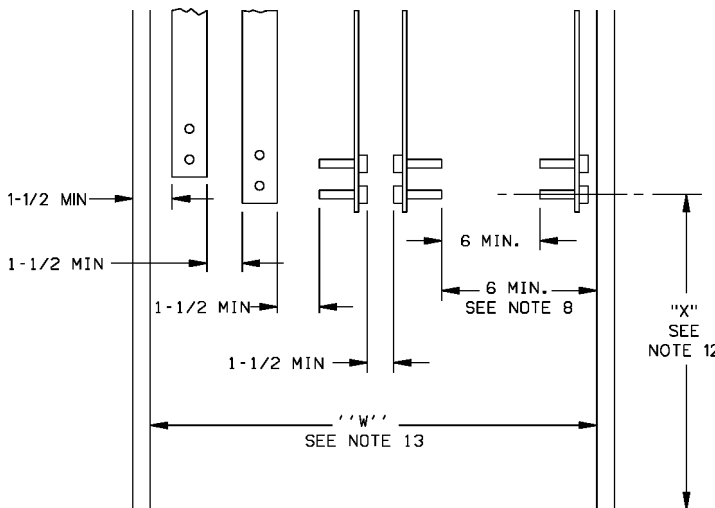

FRONT VIEW
BUS ARRANGEMENTS AND CLEARANCES
SEE NOTE 10
FIGURE 3

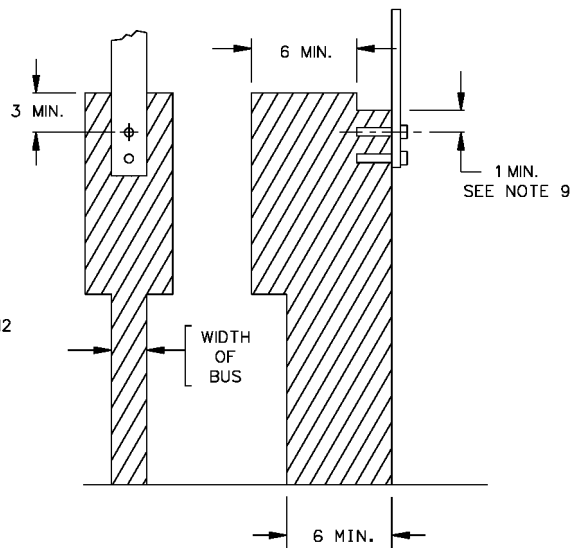

UNOBSTRUCTED WORKING SPACE
FOR ALL TERMINATIONS
SEE NOTES 8, 9, 10 AND 11
FIGURE 4

CABLE TERMINATING FACILITIES IN PULL BOXES AND PULL SECTIONS (Cont.)**NOTES:**

1. One landing position is required for each 400 amperes of service ampacity or fraction thereof (i.e., one position for up to 400 amperes, two positions for 401 through 800 amperes, three positions for 801 through 1200 amperes, etc.). Each landing position shall consist of two 1/2-inch steel bolts. The bolts shall extend from 2 inches to 2-1/2 inches from the mounting surface and be spaced on 1-3/4-inch vertical centers. When multiple landing positions per phase are required, the horizontal spacing between bolt positions shall be 2 inches minimum.

Note: The landing positions specified are for termination of Department supply conductors shall not be used for termination of the customer's service entrance conductors.

2. Each terminating bolt shall be furnished with a spring washer and a nut. The spring washer may be either a split-ring washer installed with a flat washer or a conical (Belleville) washer. Bolts shall be secured in place and spaced as shown. All parts shall be plated to prevent corrosion.

Note 1: When conical washers are used, the manufacturer shall provide a readily visible label in the compartment clearly identifying the recommended torque setting for the bolt assemblies used with the washers. The label shall not be installed on removable or hinged access cover panels.

Note 2: "Secured in place" means that the stud will not turn, back out, or loosen in any manner when tightening or loosening the terminal nuts (including cross-threaded situations).

3. Terminating bus units shall be secured to prevent turning or misalignment of the bus with the service conductors installed. Terminating bolts shall not be used to secure the bus in place.
4. No more than one terminating facility shall be mounted on a side wall.
5. For 240/120-volt 3 ϕ 4-wire delta services, the power leg (measuring 208 volts-to-ground) shall be identified with an orange color.
6. The neutral terminating position shall be permanently identified in clearly visible block lettering reading either "neutral" or "N".
7. In the termination mounting area (See figure 2), the minimum clearance from any energized part to any surface of a different potential shall be 1-1/2 inches, except:
 - a. The minimum clearance to the enclosure wall behind a terminating facility may be reduced to 1 inch.
 - b. The minimum clearance to any fully insulated bus behind a terminating facility may be reduced to 1 inch.
 - c. The minimum clearance from the neutral termination to any grounded surface may be reduced to 1 inch.

Note: Energized parts shall include all electrically conductive protrusions from the termination as well as Department-installed termination lugs.

8. A clear and unobstructed working space shall be provided in front each terminating facility as shown in figure 4, except:
 - a. For terminating facilities with bolts facing the access opening, the required 1-1/2 -inch side clearance (bus to access opening return flange) may be reduced to 3/4 inch.
 - b. For edgewise terminating facilities with bolts facing the side of the enclosure, the required 6 inch clearance from the end of the bolt shall be measured to the edge of the enclosure access opening.

Date: 05-02-24

SERVICE AND METERING EQUIPMENT, 0 - 600 VOLTS

CABLE TERMINATING FACILITIES IN PULL BOXES AND PULL SECTIONS (Cont.)

9. The clearance directly above and measured from the center of the top terminating bolt may be reduced to 1 inch to either an insulated surface or bus of the same potential.
10. Access must be provided from the front of the pull section to each terminating facility to allow installation under energized conditions. Brackets and braces used to support the terminating facilities shall be located in the area above the required unobstructed working space (See figure 4).
11. For switchboard pull sections, the minimum clearance from any energized part to a removable access cover panel shall be 4 inches. This dimension may be reduced to 1-1/2 inches if a removable safety barrier is provided by the manufacturer. The safety barrier, when provided, shall:
 - a. Be constructed of a rigid insulating material, resistant to damage by impact or puncture, with a minimum thickness of 1/8 inch.
 - b. Extend a minimum of 10 inches below the terminating bus and extend upward to cover all energized parts that are less than 4 inches from the cover.

Note: Brackets and associated hardware used to mount the safety barrier shall not extend into the provided access opening except in the area above the terminating facilities.
 - c. Have a caution sign attached to the barrier reading "**WARNING: THIS BARRIER MUST BE INSTALLED BEFORE REPLACING PULL SECTION COVERS**". Additional caution signs shall be attached to the exterior of each pull section cover reading "**DO NOT REPLACE PULL SECTION COVERS UNTIL SAFETY BARRIER IS IN PLACE**".
12. The termination height (x) varies for different applications. See note 14 for application references.
13. The access opening dimension (W) is measured between the inside edges of the left and right side return flanges.
14. References:
 - a. For additional clearance and installation requirements in pull boxes and pull sections, see pages 2-10, 2-16, 2-18, 2-22, 3-44 and 3-46.
 - b. For installation and clearance requirements in pull sections rated 2400 volts through 4800 volts, see page 4-18.
 - c. For installation and clearance requirements in pull sections rated 34500 volts, see page 4-34.

UNDERGROUND PULL BOX WITHOUT CABLE TERMINATING FACILITIES

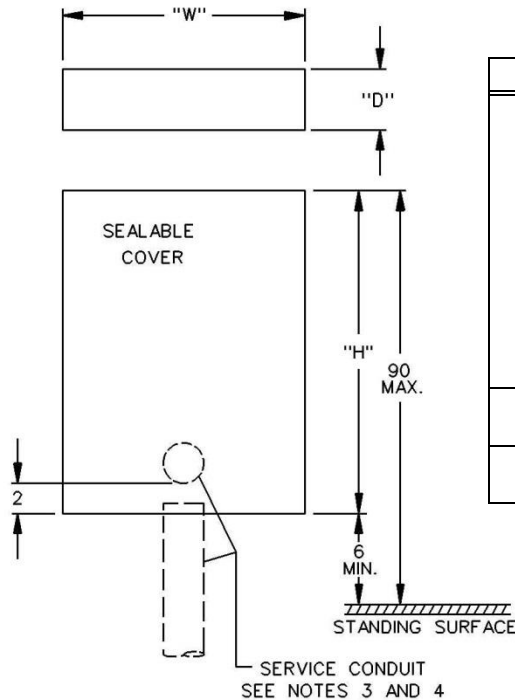

CONDUIT SIZE	"W"	"H"	"D"	AMPACITY
3"	10"	12"	4"	0-200A
	8"	18"	4"	
	12"	16"	6"	
	8"	18"	6"	
4"	18"	30"	10"	0-400A
5"	24"	36"	11"	

NOTES:

1. The pull box illustrated is for use when only a single set of service entrance conductors enter the pull box. When more than one set of service entrance conductors are installed, or Y-splices are required to join the Department-installed conductors and the customer-installed conductors, install a pull box with terminating facilities.
2. Extend service entrance conductors at least 1-1/2 times the long dimension of the pull box.
3. The service supply conduit shall enter the end or the back within 2 inches of the end but shall not enter the side. When the service supply conduit enters the end of a pull box, the opposite end shall not be less than 24 inches from obstructions projecting more than the depth of the box from the surface on which the pull box is mounted.
4. References:
 - a. For pull box with cable terminating facilities, see page 2-16.
 - b. For sealing requirements, see page 2-9.
 - c. For lifting handle requirements, see page 2-9.
 - d. For general requirements, see page 2-8.

**UNDERGROUND PULL BOX WITH CABLE TERMINATING FACILITIES
1200 AMPERES MAXIMUM**

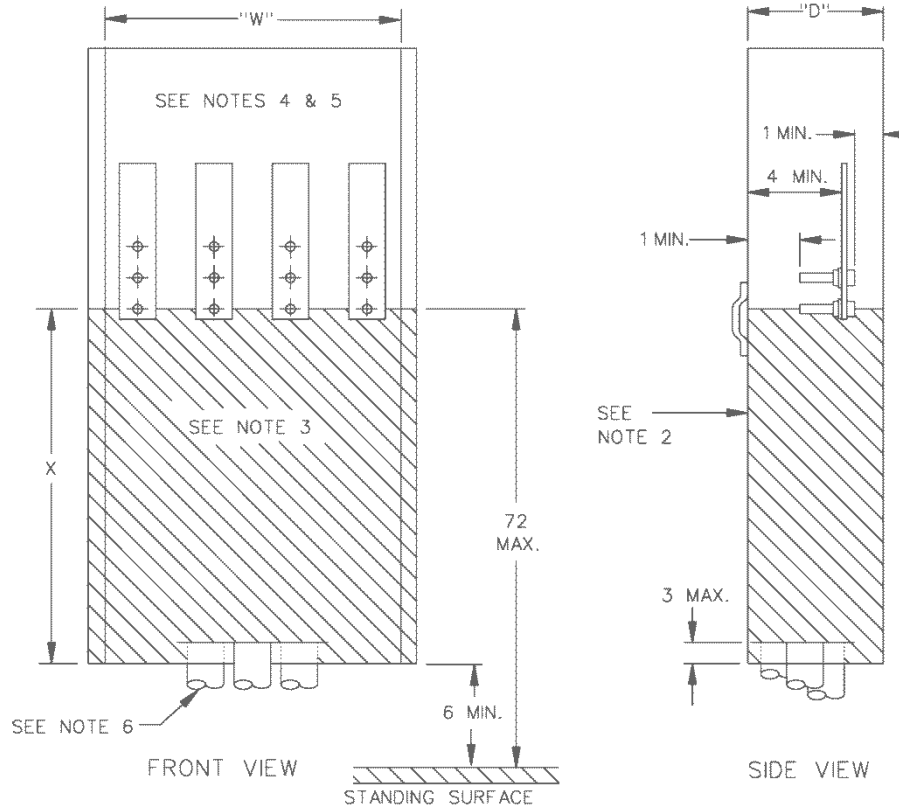

MINIMUM PULL BOX DIMENSIONS

PULL BOX RATING (AMPERES)	"W" (SEE NOTE 1)		"D"	"X"
	3-WIRE	4-WIRE		
0 - 400	10-1/2"	14"	6"	22"
401 - 800	16-1/2"	22"	11"	26"
801 - 1200	22-1/2"	30"	11"	26"

NOTES:

1. The minimum access opening dimension (W) is measured between the inside edges of the left and right side return flanges.
2. Pull box access covers shall be:
 - a. Independent of other service equipment and removable without disturbing adjacent panels.
 - b. Sealable, provided with lifting handles, and limited to 9 square feet in area with a maximum width or height of 5 feet.
3. The area below the terminating facilities (shaded space) is reserved for the Department's service supply conductors.

UNDERGROUND PULL BOX WITH CABLE TERMINATING FACILITIES (Cont.)

4. Customer-installed (service entrance) conductors shall leave the pull box in the area above the terminating facilities.
5. Service supply conduits shall enter the bottom of the pull box.
6. References:
 - a. For cable terminating facility requirements, see page 2-12.
 - b. For sealing requirements, see page 2-9.
 - c. For lifting handle requirements, see page 2-9.
 - d. For general requirements, see page 2-8.

**COMBINATION PULL BOX WITH SERVICE MAIN DISCONNECT
FOR MULTIPLE-METER SERVICES
1200 AMPERES MAXIMUM**

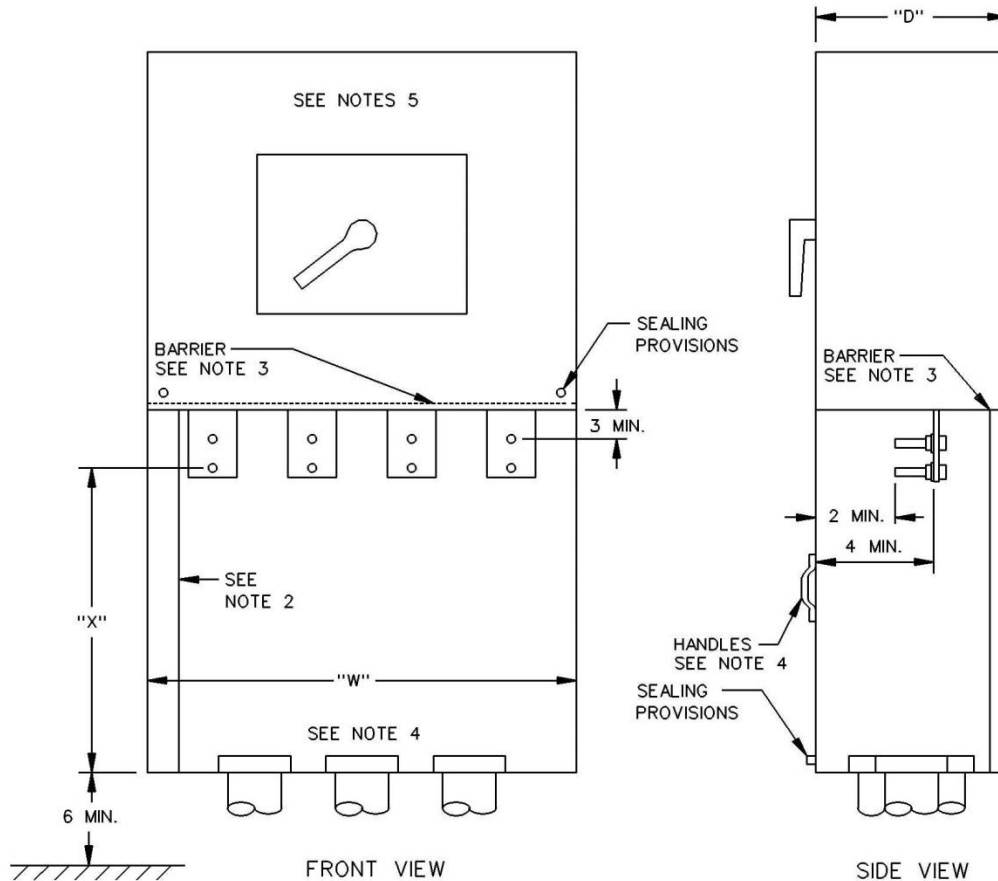

MINIMUM PULL BOX DIMENSIONS

PULL BOX RATING (AMPERES)	"W" (SEE NOTE 6)		"D"	"X"
	3-WIRE	4-WIRE		
0 - 400	10-1/2"	14"	6"	22"
401 - 800	16-1/2"	22"	11"	26"
801 - 1200	22-1/2"	30"	11"	26"

NOTES:

1. A vertical clearance of 3-inches minimum shall be maintained between the centerline of the top bolts of the terminating facilities to any obstruction.
2. A fully-enclosed, factory-installed wireway shall be provided by the manufacturer for installation of the ground electrode conductor. The wireway shall not intrude into the required termination working space or reduce any other specified clearances.
3. A full width and depth insulated, rigid barrier shall be provided to separate the pull box area from the service main disconnect compartment.

COMBINATION PULL BOX WITH SERVICE MAIN DISCONNECT (Cont.)

4. The pull section cover shall be:
 - a. Independent of other equipment and removable without disturbing adjacent panels.
 - b. Sealable, provided with two lifting handles and limited to a maximum of 9 square feet in area.
5. The main disconnect cover shall be sealable.
6. The minimum access opening dimension (W) is measured between the inside edges of the left and right side return flanges.
7. References:
 - a. For cable terminating facility requirements, see page 2-12.
 - b. For sealing requirements, see page 2-9.
 - c. For lifting handle requirements, see page 2-9.
 - d. For general requirements, see page 2-8.
 - e. For service main disconnect requirements, see page 2-7.

**COMBINATION PULL BOX AND METER SOCKET WITH SERVICE DISCONNECT
FOR SINGLE-FAMILY RESIDENTIAL SERVICES
225 AMPERES MAXIMUM, 0-600 VOLTS 1Ø 3-WIRE**

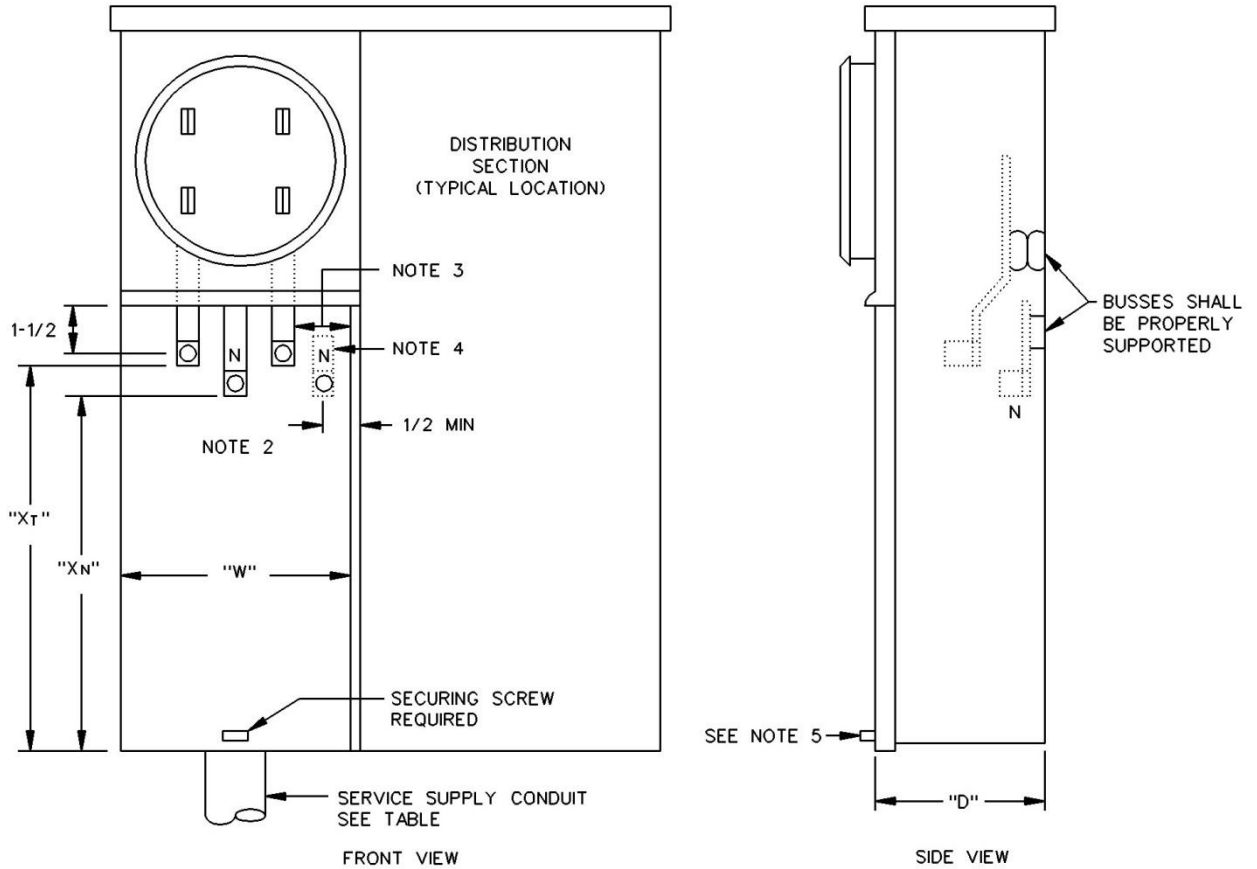

MINIMUM PANEL DIMENSIONS

PANEL RATING (AMPERES)					CONDUIT RANGE SEE NOTE 6
	"W"	"D"	"XT"	"XN"	
125	6-1/2"	4"	8"	6"	1-1/4" - 2-1/2"
225	6-1/2"	5"	11"	8-1/2"	1-1/2" - 3"

Note: the "W" dimension is the minimum pull section access opening.

NOTES:

1. This equipment may be constructed for underground service supply only or as a combination panel allowing either overhead/underground service supply applications.
2. Only one set of terminating facilities shall be provided and located as shown for both underground and overhead service supply applications. The terminating facilities for the service conductors shall be aluminum-bodied, pressure-type lugs with a range of No. 6 AWG through 1/0 AWG for the 125 ampere device and 1/0 AWG through 250 KCMIL for the 225 ampere device.

COMBINATION PULL BOX AND METER SOCKET WITH SERVICE DISCONNECT (Cont.)

3. A minimum radial clearance of 1-1/2 inches is required between energized bus terminals and between energized bus terminals and grounded or neutral surfaces.

Exception: The minimum clearance to the enclosure wall behind a terminating facility may be reduced to 1-inch.

Note: Clearances given are minimum for the bus configuration shown. Alternate configurations require Department approval and shall not reduce the minimum working clearances shown.

4. Provide a bonding jumper or screw if the neutral terminal is insulated from the enclosure.
5. The pull section cover shall be sealable from the front and provided with a securing screw.
6. Underground service supply conduit shall enter the bottom of the terminating pull section.
7. References:
- a. For sealing requirements, see page 2-9.
 - b. For general requirements, see page 2-8.

Date: 05-02-24

SERVICE AND METERING EQUIPMENT, 0 - 600 VOLTS

EUSERC DWG. 302A

ALL DIMENSIONS SHOWN ARE IN INCHES

**COMBINATION PULL BOX AND METER SOCKET WITH SERVICE DISCONNECT
FOR SINGLE-FAMILY RESIDENTIAL SERVICES
400 AMPERES (CLASS 320), 120/240 VOLTS 1Ø 3-WIRE**

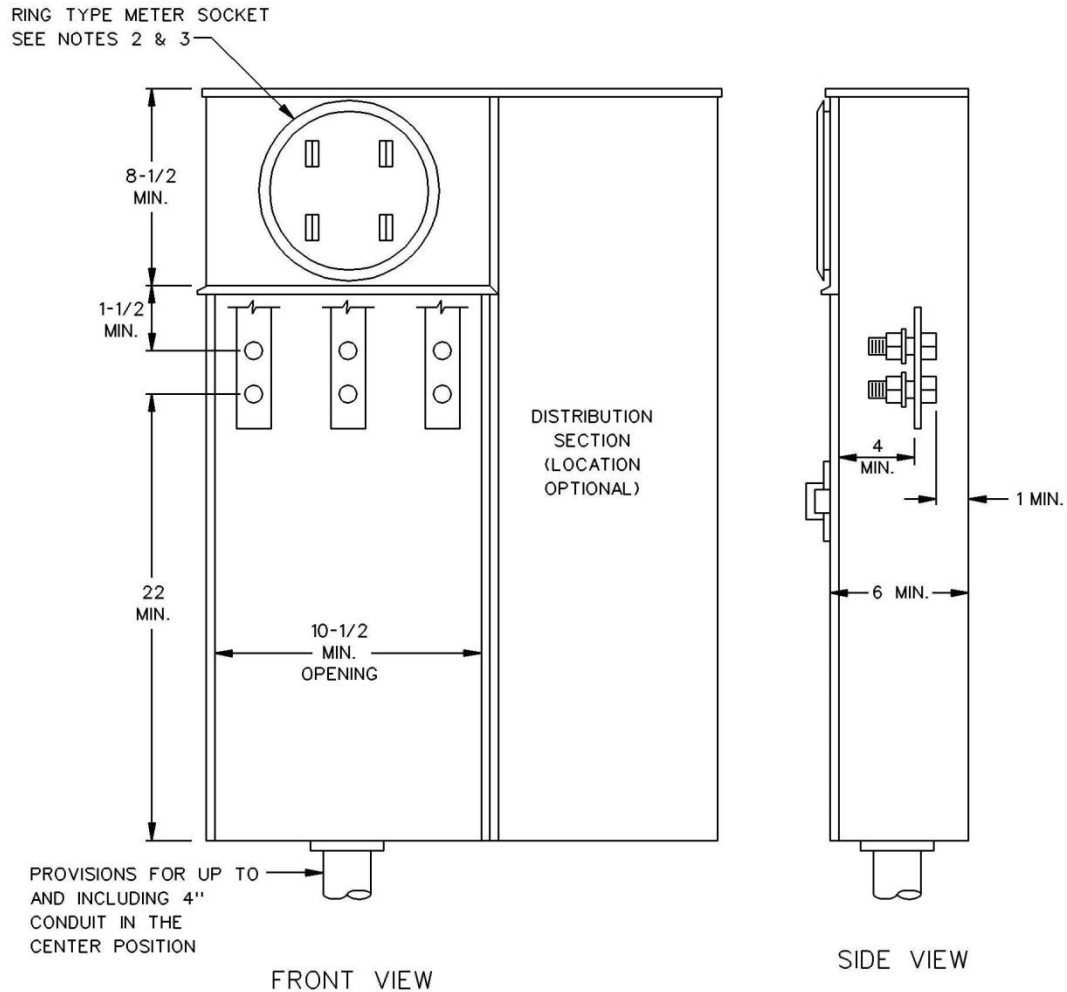
**NOTES:**

1. Meter panel shall be labeled with a 320 ampere continuous-duty rating.
2. Ringless type sockets are not permitted.
3. Socket type bypass devices of any type are not acceptable.
4. Pull box cover panels shall be removable, sealable and provided with a securing screw and lifting handles.
5. References:
 - a. For cable terminating facilities requirements, see page 2-12.
 - b. For sealing requirements, see page 2-9.
 - c. For lifting handle requirements, see page 2-9.
 - d. For general requirements, see page 2-8.

**THIS PAGE LEFT
INTENTIONALLY BLANK**

**TYPICAL PULL BOX ARRANGEMENTS WITH MULTI-METER PANELS
FOR RESIDENTIAL SERVICES (6 METERS MAXIMUM)
200-600 AMPERES, 1Ø 3-WIRE**

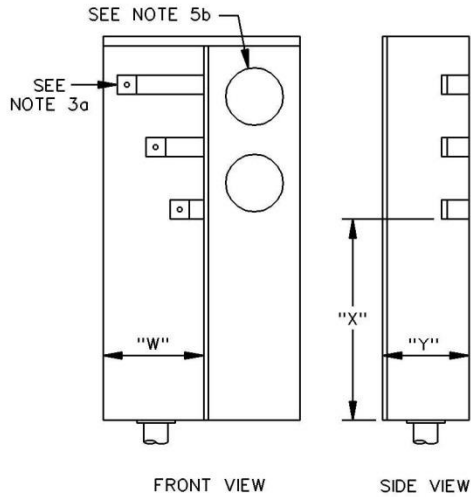

FIG. 1

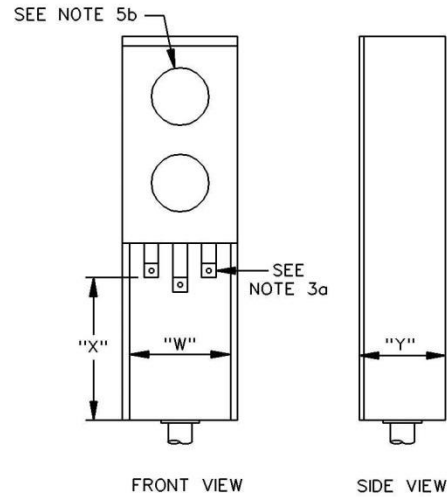

FIG. 2

TYPICAL SERVICE TERMINATING ARRANGEMENTS, 2 METERS (200 AMPERES)

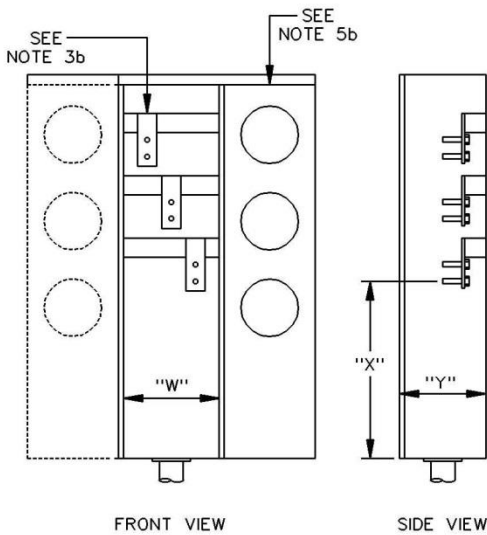

FIG. 3

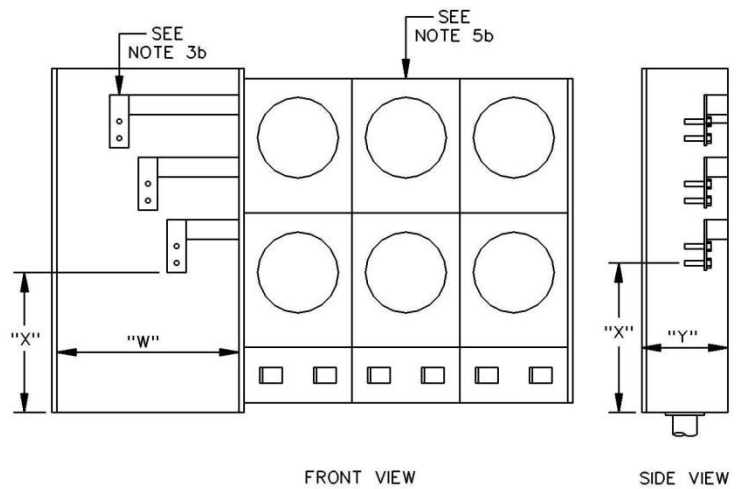

FIG. 4

TYPICAL SERVICE TERMINATING ARRANGEMENTS, 3-6 METERS (201-600 AMPERES)

SERVICE AND METERING EQUIPMENT, 0 - 600 VOLTS

Date: 05-02-24

TYPICAL PULL BOX ARRANGEMENTS WITH MULTI-METER PANELS (Cont.)

EQUIPMENT RATING (AMPERES)	"W" SEE NOTE 2	"Y"	"X"
			SEE NOTES 3c AND 3d
0 - 200	6-1/2"	5-1/2"	11"
201 - 600	10-1/2"	6	22"

NOTES:

1. Pull section covers shall be removable without disturbing adjacent panels, provided with lifting handles, sealable and limited in area to 9 square feet in area.
2. The minimum pull section access opening (W) is measured between the left side and right side return flanges.
3. Terminating facilities for service supply conductors shall be provided as follows:
 - a. For equipment rated 200 amperes (continuous), terminations shall be aluminum-bodied, mechanical lugs with a range of 1/0 AWG through 250 KCMIL. See page 2-20 for termination details and clearance requirements
 - b. For equipment rated 201-600 amperes (continuous), terminations shall be two 1/2-inch steel bolts with washers and nuts. See page 2-12 for termination details and clearance requirements.
 - c. The neutral terminating position shall be identified. A bonding screw or jumper shall be provided if the neutral terminal is insulated from the enclosure.
 - d. The neutral terminating position height may be reduced to 8-1/2 inches for equipment rated 200 amperes.
4. Cross-bussing of a different phase or potential installed behind or below any terminating position shall be fully insulated or barriered. Insulating barriers shall be a rigid, nonflammable material rated for the serving voltage, resistant to ARC tracking, resistant to puncture or damage by impact, and attached with non-conducting fasteners.
5. Additional references:
 - a. For meter socket clearance and panel requirements, see page 3-36.
 - b. For sealing requirements, see page 2-9.
 - c. For lifting handle requirements, see page 2-9.
 - d. For general requirements, see page 2-8.

Date: 01-01-09

SERVICE AND METERING EQUIPMENT, 0 - 600 VOLTS

EUSERC DWG. 304 AND 305

ALL DIMENSIONS SHOWN ARE IN INCHES

**SAFETY-SOCKET METER PANEL
100 AND 200 AMPERES**

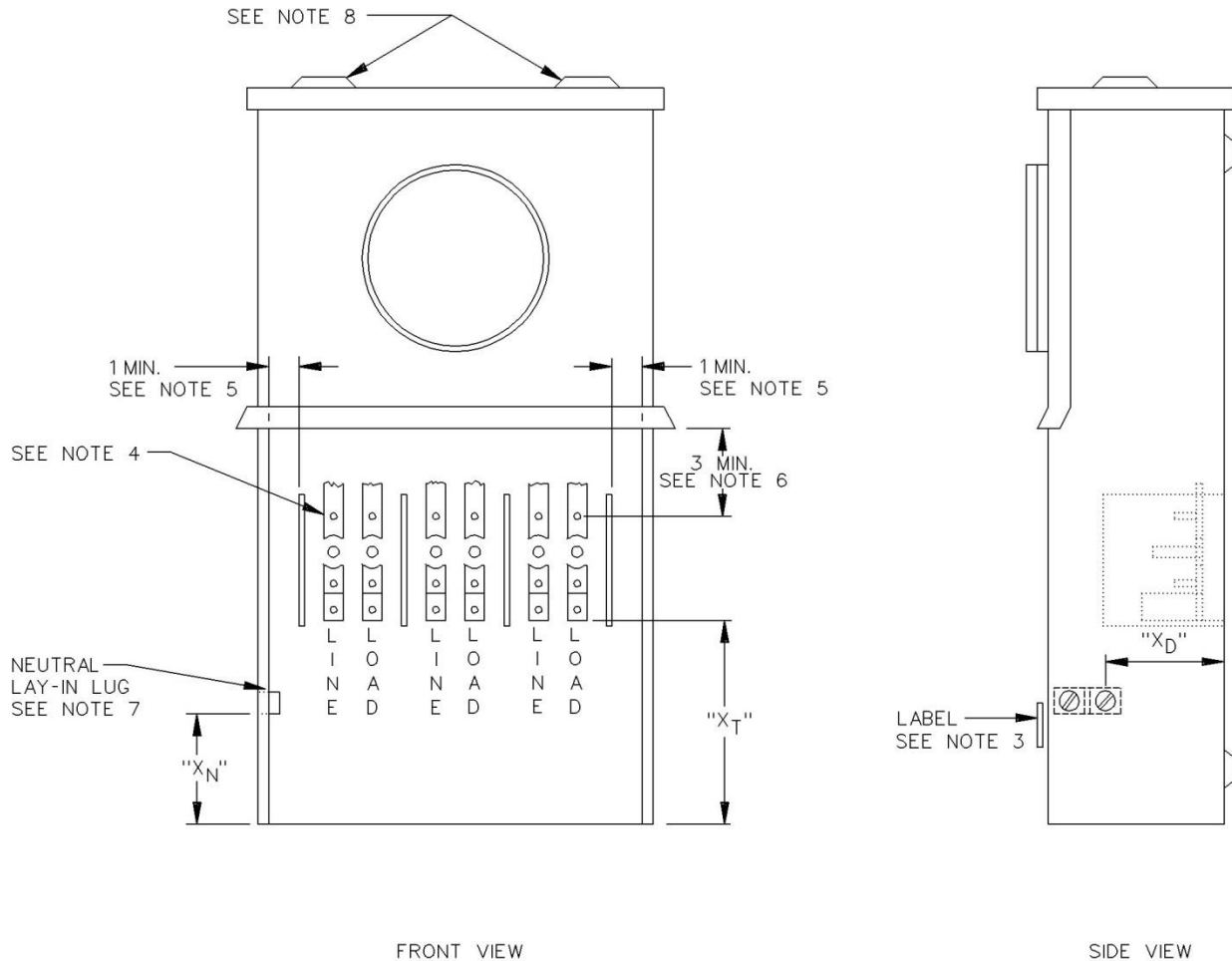

TABLE - MINIMUM DIMENSIONS

PANEL TYPE	PANEL RATING* (AMPERES)	"X _T "	"X _N "	"X _D "
STANDARD	100	8"	5"	2" - 3"
HEAVY-DUTY	200	11"	8"	3" - 3-1/2"

NOTES:

1. Meter sockets shall be mounted on a rigid support and attached to the meter socket panel.
2. All panels shall be removable without disturbing adjacent panels.
3. Test-bypass compartment cover panel shall be sealable, and provided with a permanent label reading "DO NOT BREAK SEALS - NO FUSES INSIDE".

SAFETY-SOCKET METER PANEL (Cont.)

4. Test-bypass blocks with rigid insulating barriers shall be furnished, installed, and bussed or wired to the meter socket by the manufacturer as follows:
 - a. For 1 \emptyset , 3-wire, provide two test-bypass blocks mounted in the outer positions and a 4-jaw socket. For 120/208 volts, 1 \emptyset 3-wire, provide two test-bypass blocks mounted in the outer positions and a 5-jaw socket. Connect the 5th jaw of the meter socket to the neutral lug with a white No. 12 AWG (minimum) copper wire.
 - b. For 3 \emptyset , 3-wire, provide three test-bypass blocks and a 5-jaw meter socket - connect the line and load poles together at the top of the center position test-bypass block with a bus section and connect the bus to the 5th jaw of the meter socket with a No. 12 AWG (minimum) copper wire. Color used to identify the wire shall not be either white, gray, green or orange.
 - c. For 3 \emptyset , 4-wire, provide three test-bypass blocks and a 7-jaw socket - connect the 7th jaw of the meter socket to the neutral lug with a white No. 12 AWG (minimum) copper wire. For 120/240 volts, 4-wire delta, the right hand test-bypass block shall be the power leg (measures 208 volts-to-ground) and shall be identified with an orange color.
 - d. Test-bypass block connection sequence shall be LINE-LOAD from left to right and shall be clearly identified in 3/4-inch minimum block letters.
 - e. Cable terminals shall be aluminum-bodied mechanical lugs with a range of no. 6 AWG through 1/0 AWG for the 100 ampere test-bypass block and no. 1/0 AWG through 250 KCMIL for the 200 ampere test-bypass block.

Note: Test-bypass compartment is not approved for use as pull box for terminating Department supply conductors.
5. One-inch (minimum) dimension measured from the edge of the compartment access opening to the test-bypass block rigid insulating barrier.
6. 3-inch (minimum) dimension measured from the upper test connector stud (stud "A") to the socket meter cover.
7. A double insulated, bondable, vertical lay-in lug for the neutral conductor shall be provided, on either side wall, in the test-bypass compartment.
8. Knockouts for the service supply conduit may be cut in the locations shown at the top of the panel.
9. Wiring requirements:
 - a. The contractor shall install and connect all line and load conductors not supplied by the manufacturer.

Note: No other customer-owned wiring or conduits may be routed through the meter or bypass compartments.
 - b. No more than one set of load conductors shall exit the compartment and all load conductors shall exit below the test-bypass blocks.
10. References:
 - a. For test-bypass block construction details, see page 2-32.
 - b. For socket meter jaw arrangements, see page 2-5.
 - c. For sealing requirements, see page 2-9.

SAFETY-SOCKET METER PANEL WITH SERVICE DISCONNECT
100 AND 200 AMPERES

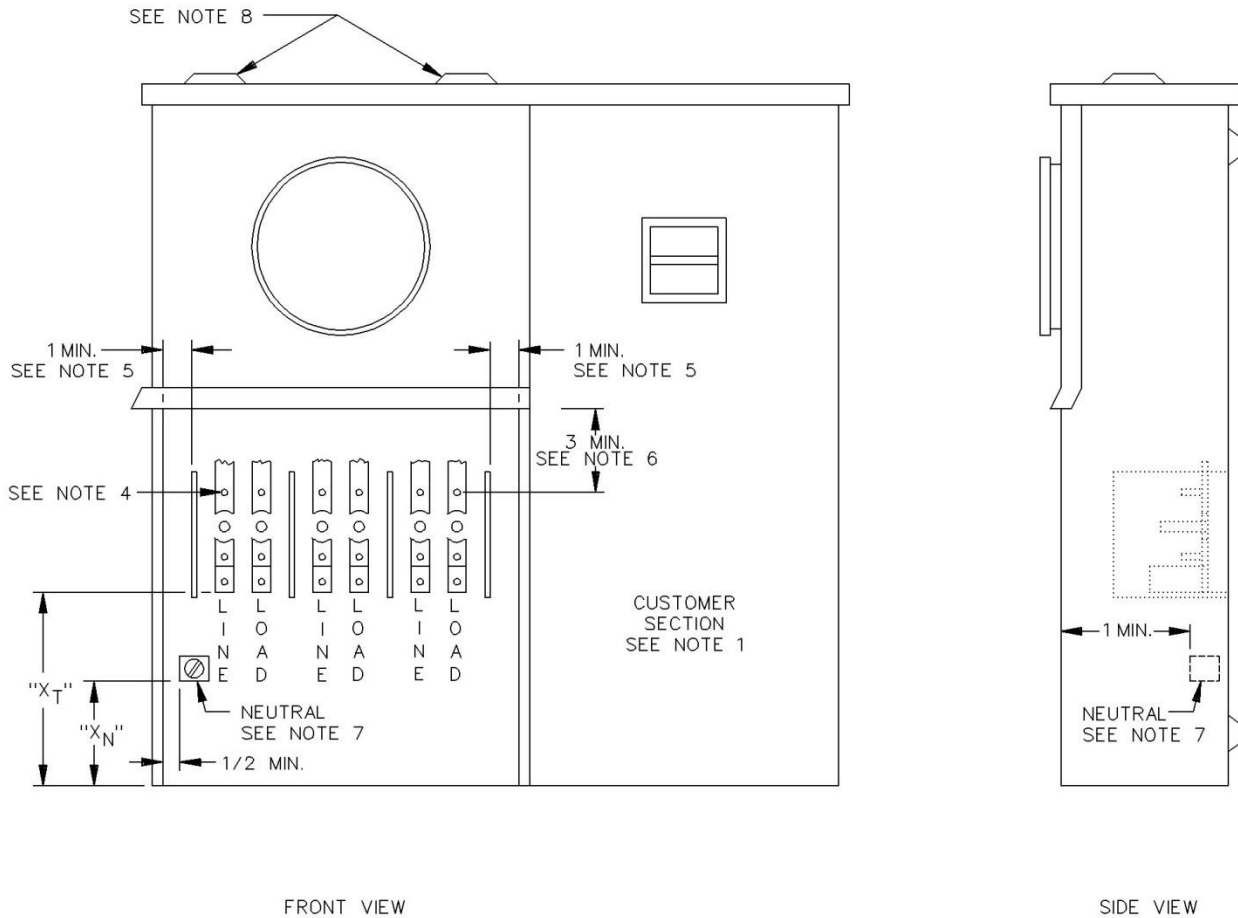

TABLE - MINIMUM DIMENSIONS

PANEL TYPE	PANEL RATING* (AMPERES)	"XT"	"XN"
STANDARD	100	8"	5"
HEAVY-DUTY	200	11"	8"

NOTES:

1. The panel shown above is typical with the customer's distribution section located to the side of the metering compartment. The distribution section may also be located below the test-bypass compartment (overhead supply only) or above the meter panel.
2. Meter socket shall be mounted on a rigid support and attached to the meter socket panel. Test-bypass compartment cover shall be sealable.
3. All panels shall be removable without disturbing adjacent panels.

SERVICE AND METERING EQUIPMENT, 0 - 600 VOLTSDate: 01-01-10

SAFETY-SOCKET METER PANEL WITH SERVICE DISCONNECT (Cont.)

4. Test-bypass blocks with rigid insulating barriers shall be furnished, installed, and bussed or wired to the meter socket by the manufacturer as follows:
 - a. For 1 \emptyset , 3-wire, provide two test-bypass blocks mounted in the outer positions and a 4-jaw socket. For 120/208 volts, 1 \emptyset 3-wire, provide two test-bypass blocks mounted in the outer positions and a 5-jaw socket - connect the 5th jaw of the meter socket to the neutral lug with a white No. 12 AWG (minimum) copper wire.
 - b. For 3 \emptyset , 3-wire, provide three test-bypass blocks and a 5-jaw meter socket - connect the line and load poles together at the top of the center position test-bypass block with a bus section and connect the bus to the 5th jaw of the meter socket with a No. 12 AWG (minimum) copper wire. Color used to identify the wire shall not be either white, gray, green or orange.
 - c. For 3 \emptyset , 4-wire, provide three test-bypass blocks and a 7-jaw socket - connect the 7th jaw of the meter socket to the neutral lug with a white No. 12 AWG (minimum) copper wire. For 120/240 volts, 4-wire delta, the right hand test-bypass block shall be the power leg (measures 208 volts-to-ground) and shall be identified with an orange color.
 - d. Test-bypass block connection sequence shall be LINE-LOAD from left to right and shall be clearly identified in 3/4-inch minimum block letters.
 - e. Cable terminals shall be aluminum-bodied mechanical lugs with a range of no. 6 AWG through 1/0 AWG for the 100 ampere test-bypass block and no. 1/0 AWG through 250 KCMIL for the 200 ampere test-bypass block.

Note: Test-bypass compartment is not approved for use as pull box for terminating Department supply conductors.
5. One-inch (minimum) dimension measured from the edge of the compartment access opening to the test-bypass block rigid insulating barrier.
6. 3-inch (minimum) dimension measured from the upper test connector stud (stud "A") to the socket meter cover.
7. The neutral terminal may be provided as follows:
 - a. A single mechanical lug or lay-in lug, located on either side wall. The lug shall be mounted on a neutral bus bar extending into, and terminating in, the customer section.
 - b. Two mechanical lugs or lay-in lugs, located on either side wall. The neutral conductor provided from one of the lugs to the neutral bus in the customer section may be factory or field installed.
 - c. Overhead supply only - a single insulated, bondable, vertical, lay-in lug located on either side wall with the neutral conductor installed unbroken through the lug and terminating on the neutral bus in the customer section.
8. Knockouts for the service supply conduit may be cut in the locations shown at the top of the panel.
9. Wiring requirements:
 - a. The contractor shall install and connect all line and load conductors not supplied by the manufacturer.

Note: No other customer-owned wiring or conduits may be routed through the meter or bypass compartments.

SAFETY-SOCKET METER PANEL WITH SERVICE DISCONNECT (Cont.)

10. References:

- a. For test-bypass block construction details, see page 2-32.
- b. For socket meter jaw arrangements, see page 2-5.
- c. For sealing requirements, see page 2-9.

**THIS PAGE LEFT
INTENTIONALLY BLANK**

Date: 01-01-04

SERVICE AND METERING EQUIPMENT, 0 - 600 VOLTS

EUSERC DWG. 311

ALL DIMENSIONS SHOWN ARE IN INCHES

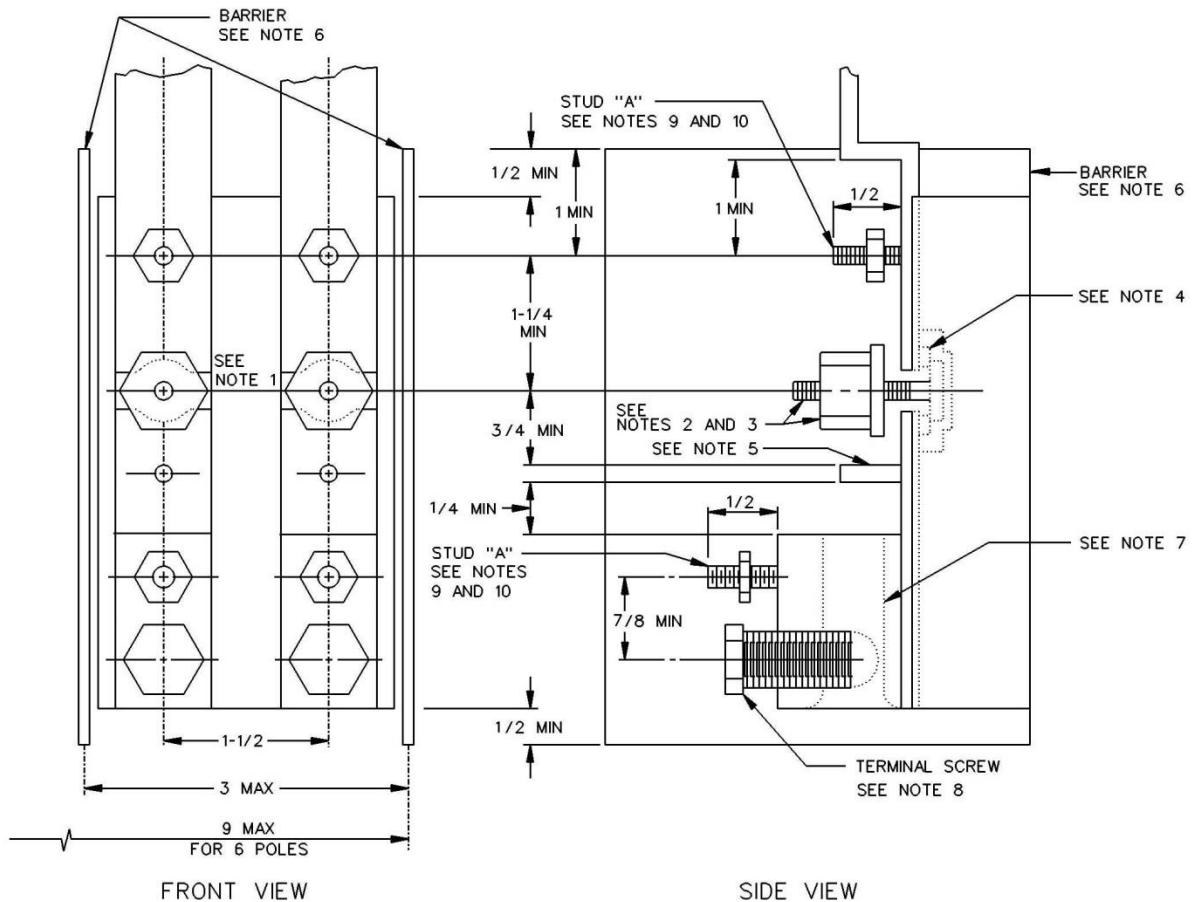
TEST-BYPASS BLOCKS FOR SAFETY SOCKETS
100 AND 200 AMPERES**NOTES:**

1. The strike distance between upper and lower bus sections shall not be less than 1/4-inch when the circuit-closing nut is backed off.
2. The circuit-closing nut shall be a hex nut, measuring 5/8-inch across flats, with an attached plated copper washer and have threads counter-bored at the bottom of the nut to allow easy re-installation of the nut. The circuit-closing bolt shall be secured to prevent the bolt from turning or backing out.
3. The circuit-closing nut and bolt assembly shall maintain the applied contact pressure between the plated copper washer and the bus sections of the test-bypass block.
4. The insulating washer shall be made from dimensionally stable material resistant to ARC tracking and shall provide a minimum of 1/8-inch creep distance between the bolt and the bus section. Bus sections shall be plated.
5. The wire stops shall extend from the bus to the center of, or beyond, the terminal opening provided for the cable.

TEST-BYPASS BLOCKS FOR SAFETY SOCKETS (Cont.)

6. Rigid insulating barriers shall project at least 1/4-inch beyond any energized parts when the maximum wire size is installed.
7. Cable terminals shall be aluminum-bodied, mechanical lugs. The hole in the terminal body for the cable shall extend through the terminal body. If the hole opening is round, the opening shall be chamfered for ease of installation of the largest wire size.
8. The terminal screw may be of the allen type, measuring 3/16-inch across the flats, for the 100 ampere test-bypass block and 5/16-inch across the flats for the 200 ampere test-bypass block.
9. The test connector studs ("A") shall be a 12-24 stud with a hex nut measuring 1/2 inch across the flats.
10. The test connector studs ("A") shall be provided in both the upper and lower positions as shown. In the lower position, the studs may be located either on the terminal body, on the bus member between the circuit-closing nut and the wire stop or incorporated as part of the wire stop.
11. References:
 - a. For test-bypass block applications, see pages 2-26, 2-28, 2-44 and 3-34.

Date: 06-11-13

SERVICE AND METERING EQUIPMENT, 0 - 600 VOLTS

EUSERC DWG. 339

ALL DIMENSIONS SHOWN ARE IN INCHES

**METER SOCKET PANEL WITH TEST SWITCH MOUNTING PLATE
FOR INSTRUMENT-TRANSFORMER METERING INSTALLATIONS**

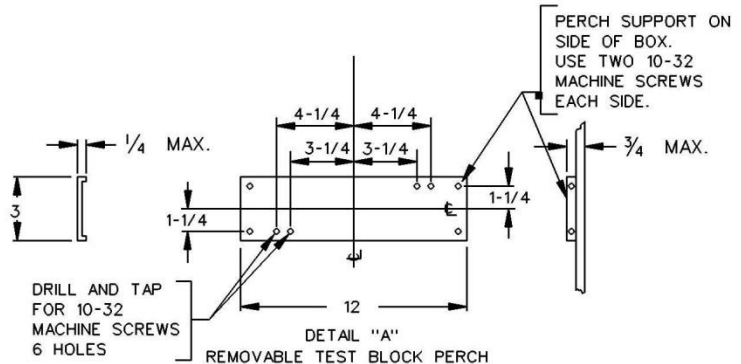
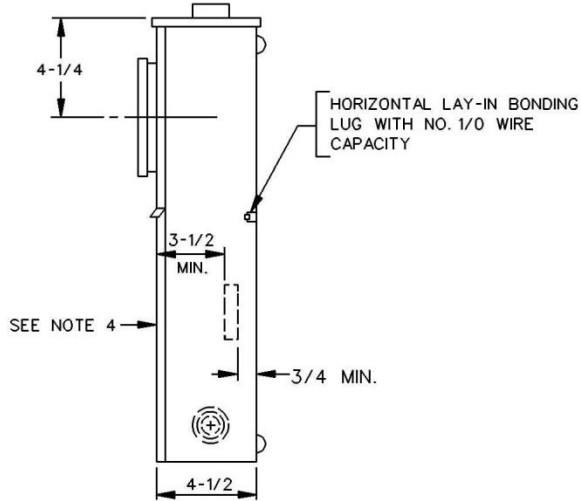
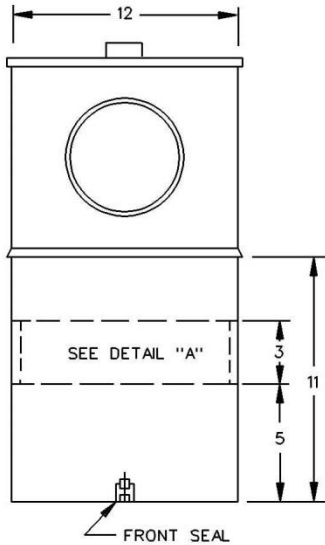

NOTES:

1. This panel is for use with instrument-transformer metering installations requiring remote meter provisions.
2. Instrument-transformer rated sockets shall be designed for front connection.
3. All section covers shall be removable without disturbing adjacent covers.
4. The meter socket panel shall not be removable when the meter is in place.
5. Test switch compartment cover panel shall be sealable and provided with a label reading "DO NOT BREAK SEAL, NO FUSES INSIDE".
6. The meter panel may be either surface mounted or semi-flush mounted.
7. References:
 - 1) For meter socket jaw arrangements, see page 2-5.
 - 2) For sealing requirements, see page 2-9.

**THIS PAGE LEFT
INTENTIONALLY BLANK**

**CURRENT-TRANSFORMER BOX WITH METER SOCKET PANEL
FOR UNDERGROUND SERVICE (See Note 1)
400 - 800 AMPERES**

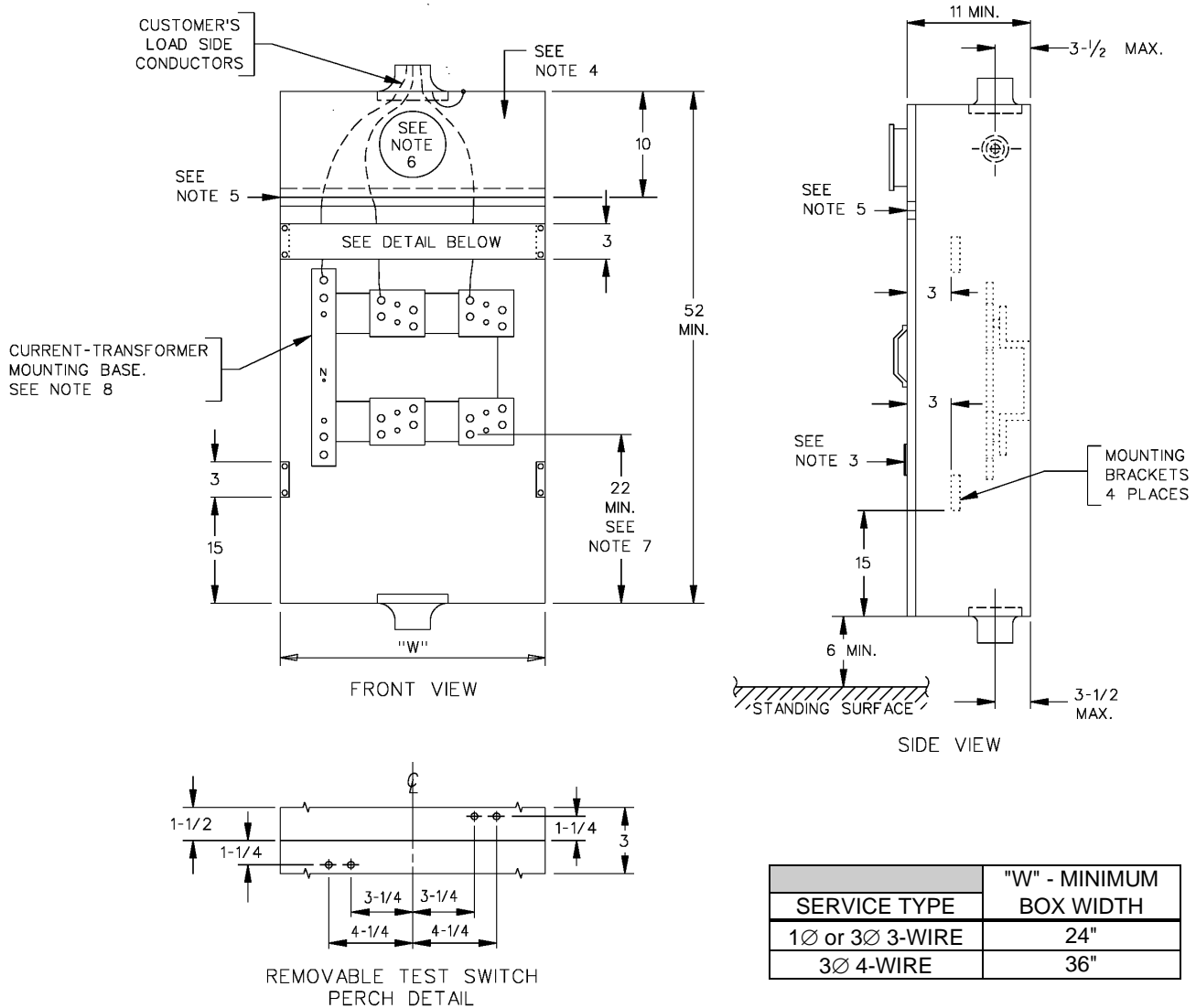

NOTES:

1. This device may be used as a terminating pull box for an underground service (**400 amperes maximum**). For 401-800 amperes, a separate underground terminating enclosure shall be required.
2. The box shall be weatherproof.
3. The current-transformer compartment cover panel(s) shall be limited to 9 square feet in area, be sealable and equipped with lifting handles and have a label reading "DO NOT BREAK SEAL - NO FUSES INSIDE".
4. The meter socket panel shall be sealable and furnished with a meter ring, meter socket and sealing ring.

CURRENT-TRANSFORMER BOX WITH METER SOCKET PANEL (Cont.)

5. A panel support bracket shall be provided as shown for the meter and current-transformer compartment panels. The meter panel shall be attached to the bracket with securing screws to prevent the panel from pulling out when the meter is removed from the socket.
6. Meter socket shall be front connected.
7. The neutral termination height may be reduced to 20 inches.
8. The current-transformer mounting base shall be furnished and installed by the customer.
9. Wiring requirements:
 - a. The customer's load conductors shall leave the box in the area above the current-transformer mounting base.
 - b. No conduits, conductors or devices other than those shown shall be installed in, or routed through, the box.
 - c. No other meters may be supplied from the box.
10. References:
 - a. For meter socket jaw arrangements, see page 2-5.
 - b. For current-transformer mounting base details, see pages 2-40 and 2-42.
 - c. For sealing requirements, see page 2-9.
 - d. For lifting handle requirements, see page 2-9.

**CURRENT-TRANSFORMER BOX WITH METER SOCKET PANEL
FOR OVERHEAD SERVICE (See Note 1)
400 - 800 AMPERES**

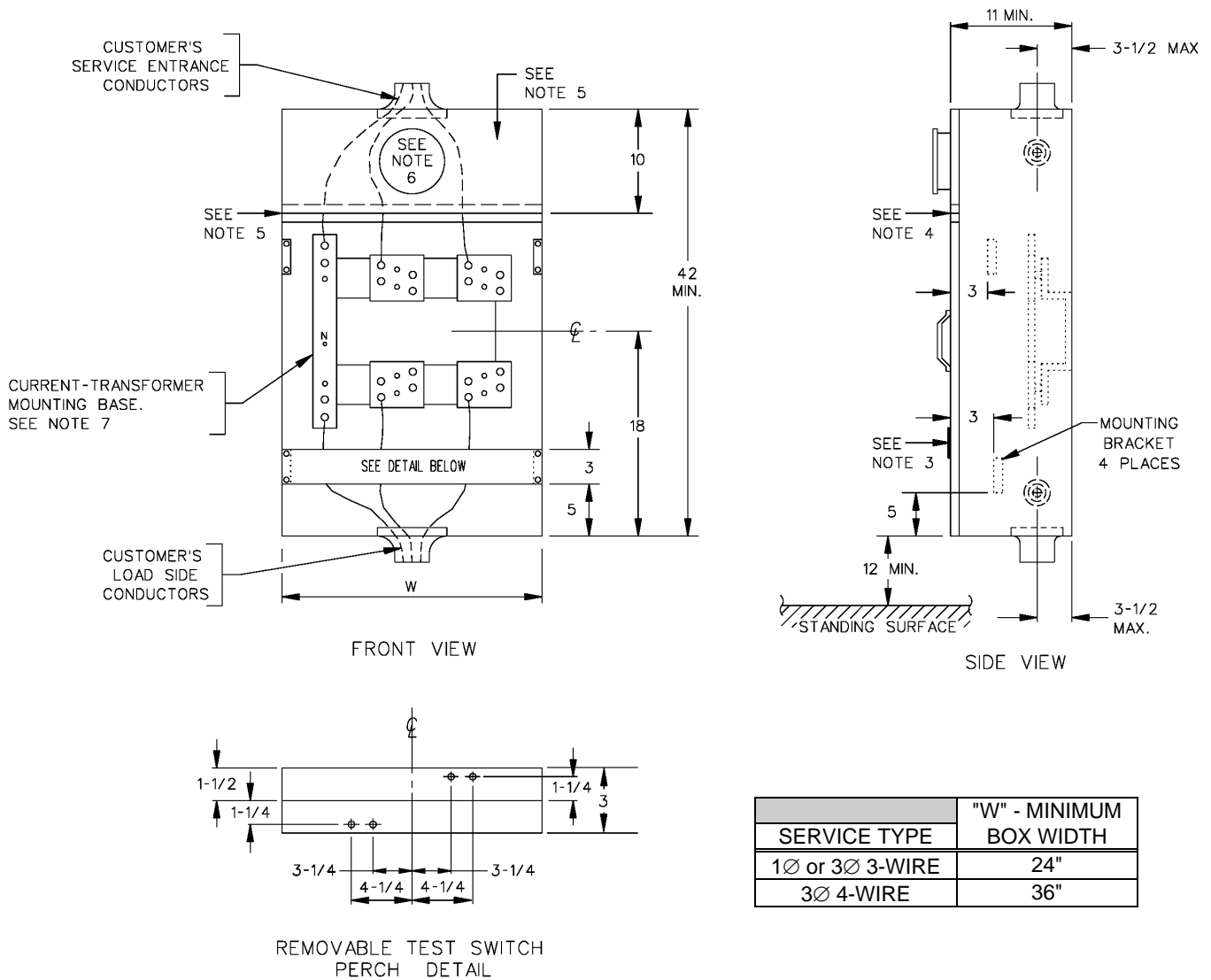

SERVICE TYPE	"W" - MINIMUM BOX WIDTH
1Ø or 3Ø 3-WIRE	24"
3Ø 4-WIRE	36"

NOTES:

1. This device may be used for an underground service when supplied from a separate underground terminating enclosure.
2. The enclosure shall be weatherproof.
3. The current-transformer compartment cover panels shall be limited to 9 square feet in area, be sealable and equipped with lifting handles, and have a label reading "DO NOT BREAK SEAL - NO FUSES INSIDE".

CURRENT-TRANSFORMER BOX WITH METER SOCKET PANEL (Cont.)

4. A panel support bracket shall be provided as shown for the meter socket and current-transformer compartment cover panels. The meter panel shall be attached to the bracket with securing screws to prevent the panel from pulling out when the meter is removed from the socket.
5. Meter socket panel shall be sealable and furnished with a meter ring, meter socket and sealing ring.
6. Meter socket shall be front connected.
7. The current-transformer mounting base shall be furnished and installed by the customer.
8. Wiring requirements:
 - a. The customer's service entrance wires shall enter the box at one end and the load wires shall leave the box at the other end.
 - b. No conduits, conductors or devices other than those shown shall be installed in, or routed through, the box.
 - c. No other meters may be supplied from the box.
9. References:
 - a. For meter socket jaw arrangements, see page 2-5.
 - b. For current-transformer mounting base details, see pages 2-40, 2-41, 2-42 and 2-43.
 - c. For sealing requirements, see page 2-9.
 - d. For lifting handle requirements, see page 2-9.

Date: 10-31-18

SERVICE AND METERING EQUIPMENT, 0 - 600 VOLTS

EUSERC DWG. 328A

ALL DIMENSIONS SHOWN ARE IN INCHES

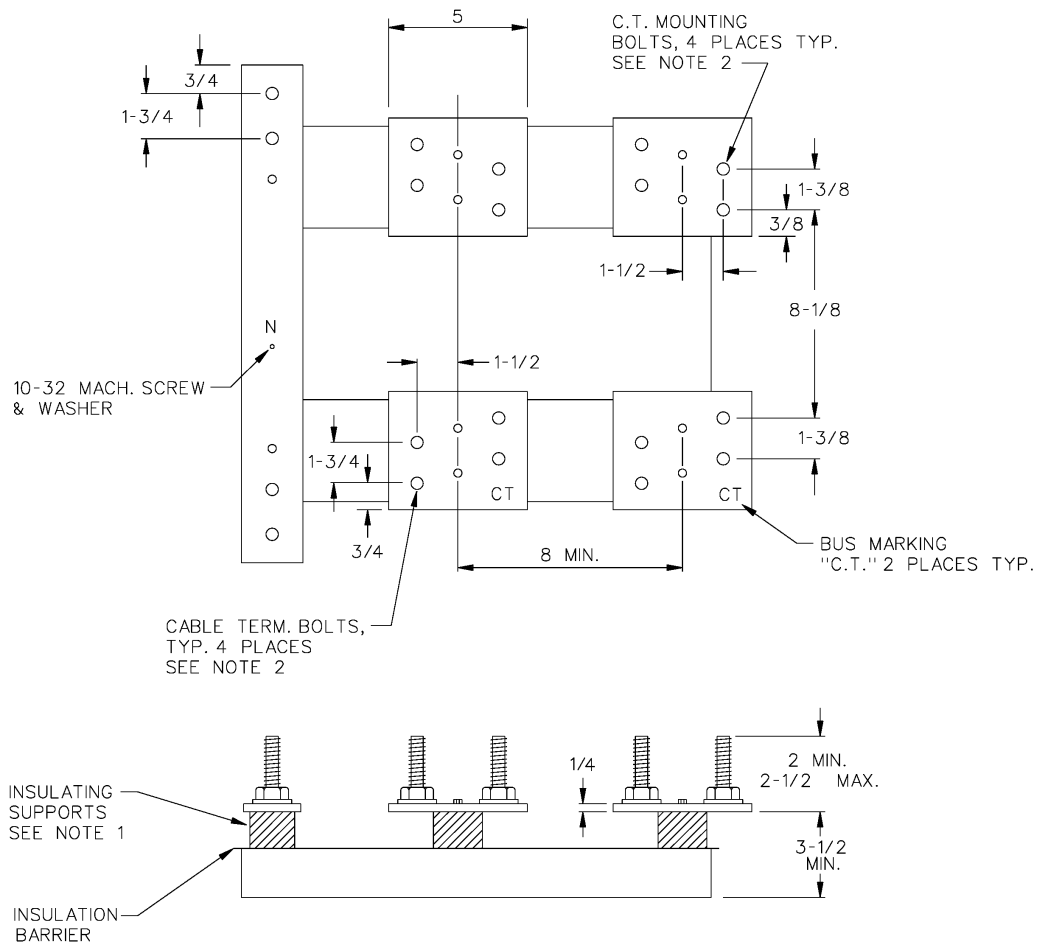
CURRENT-TRANSFORMER MOUNTING BASE
400 - 800 AMPERES, 1Ø 3-WIRE AND 3Ø 3-WIRE

NOTES:

1. Insulating supports shall be rated for the serving voltage and have sufficient mechanical strength for the application.
2. Two 1/2-inch steel bolts shall be provided for each current-transformer mounting position and cable terminating position. Each bolt shall be furnished with a spring washer and a nut. The spring washer may be either splitting washer installed with a flat washer or a conical (Belleville) washer. Bolts shall be secured in place and spaced as shown. All parts shall be plated to prevent corrosion.

Note 1: When conical washers are used, the manufacturer shall provide a readily visible label in the compartment clearly identifying the recommended torque setting for the bolt assemblies used with the washers.

Note 2: When the line or load conductors are installed by the customer, mechanical lugs may be provided in place of the studs specified above for cable terminations.

3. References:

- a. For applications, see pages 2-36 and 2-38.

CURRENT-TRANSFORMER MOUNTING BASE (OVERHEAD SUPPLY)
400 - 800 AMPERES, 1Ø 3-WIRE AND 3Ø 3-WIRE

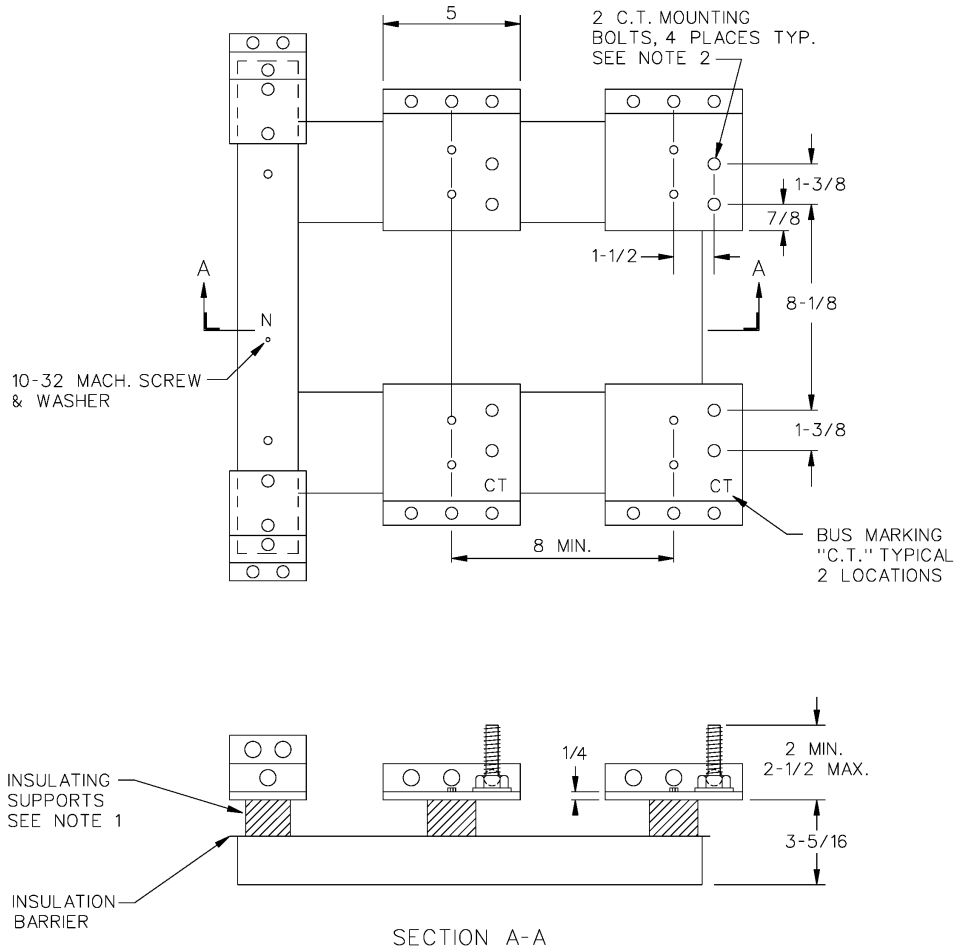

NOTES:

1. Insulating supports shall be rated for the serving voltage and have sufficient mechanical strength for the application.
2. Two 1/2-inch steel bolts shall be provided for each current-transformer mounting position. Each bolt shall be furnished with a spring washer and a nut. The spring washer may be either split-ring washer installed with a flat washer or a conical (Belleville) washer. Bolts shall be secured in place and spaced as shown. All parts shall be plated to prevent corrosion.

Note: When conical washers are used, the manufacturer shall provide a readily visible label in the compartment clearly identifying the recommended torque setting for the bolt assemblies used with the washers.

3. Terminating positions for both load and line side conductors shall be aluminum-bodied mechanical lugs and shall be sized to accept the conductor sizes required to supply the service.
4. References:
 - a. For applications, see page 2-38.

Date: 10-31-18

SERVICE AND METERING EQUIPMENT, 0 - 600 VOLTS

EUSERC DWG. 329A

ALL DIMENSIONS SHOWN ARE IN INCHES

CURRENT-TRANSFORMER MOUNTING BASE
400 - 800 AMPERES, 3Ø 4-WIRE

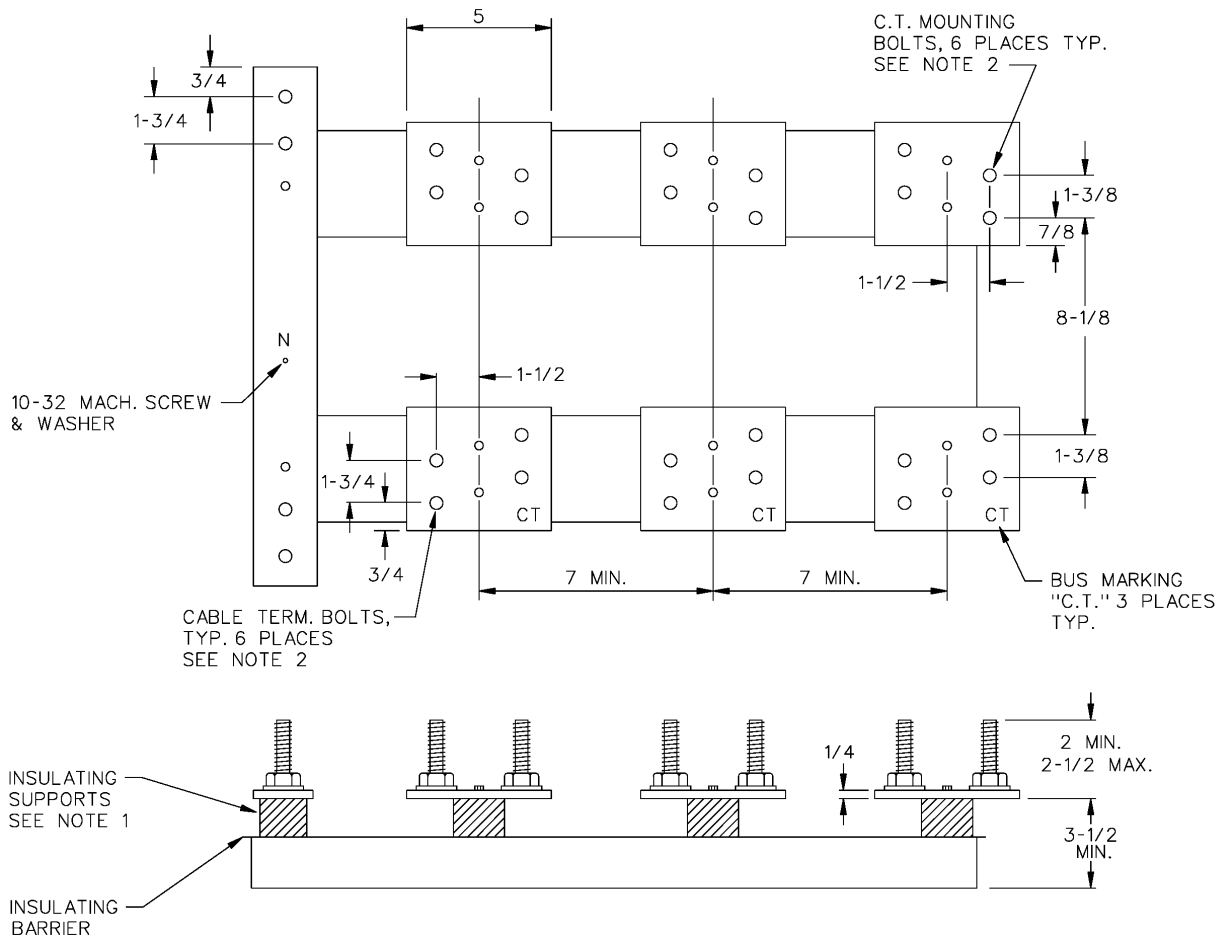

NOTES:

1. Insulating supports shall be rated for the serving voltage and have sufficient mechanical strength for the application.
2. Two 1/2-inch steel bolts shall be provided for each current-transformer mounting position and cable terminating position. Each bolt shall be furnished with a spring washer and a nut. The spring washer may be either splitting washer installed with a flat washer or a conical (Belleville) washer. Bolts shall be secured in place and spaced as shown. All parts shall be plated to prevent corrosion.

Note 1: When conical washers are used, the manufacturer shall provide a readily visible label in the compartment clearly identifying the recommended torque setting for the bolt assemblies used with the washers.

Note 2: When the line or load conductors are installed by the customer, mechanical lugs may be provided in place of the studs specified above for cable terminations.

3. References:

- a. For applications, see pages 2-36 and 2-38.

CURRENT-TRANSFORMER MOUNTING BASE (OVERHEAD SUPPLY)
400 - 800 AMPERES, 3Ø 4-WIRE

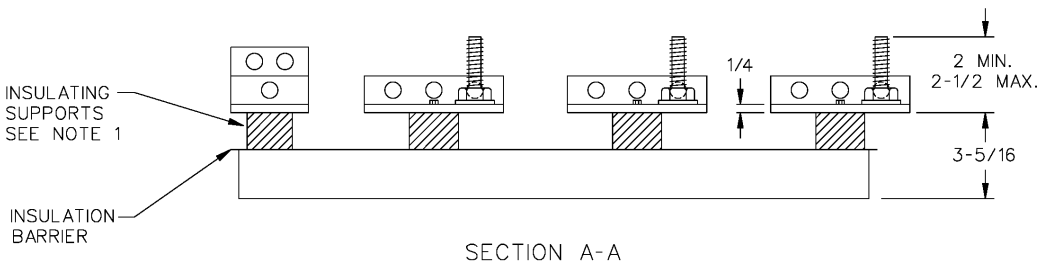
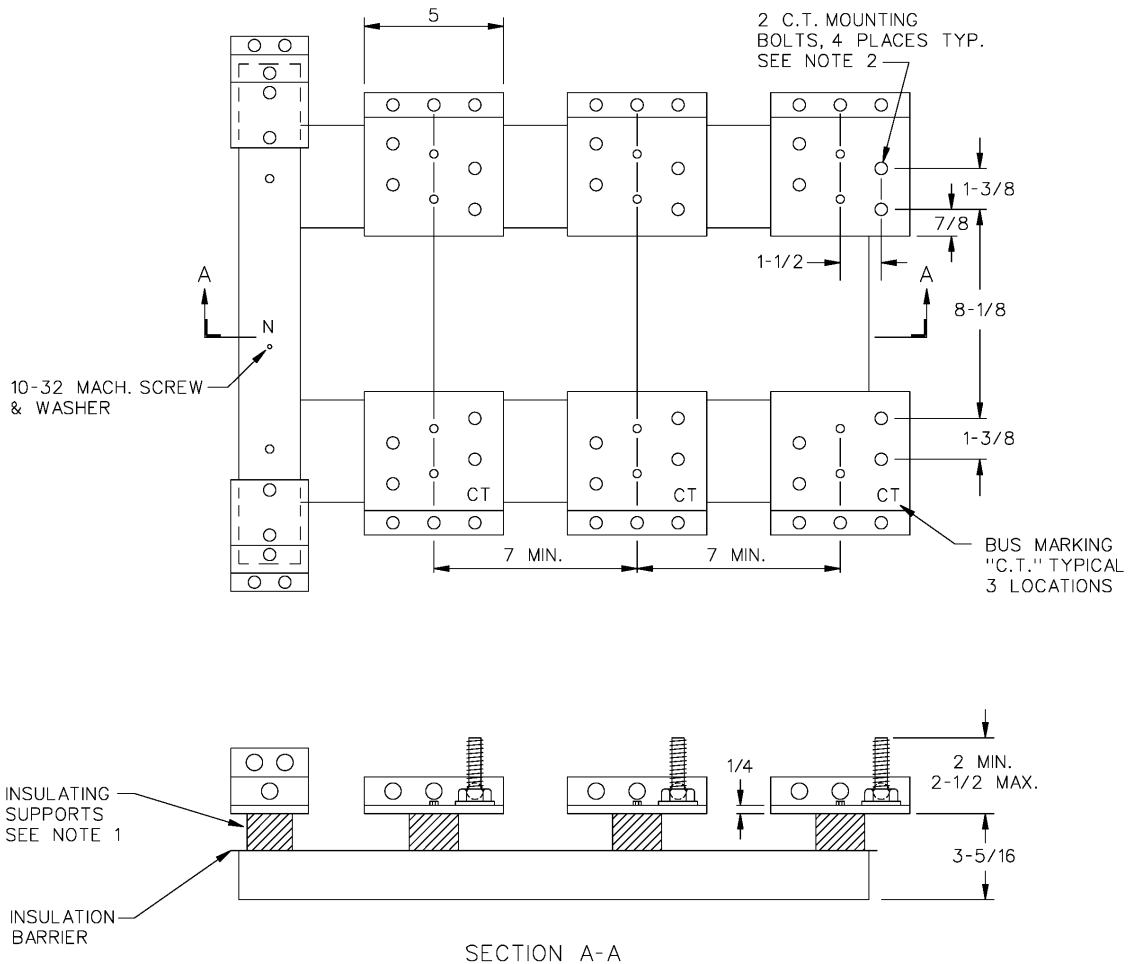

NOTES:

1. Insulating supports shall be rated for the serving voltage and have sufficient mechanical strength for the application.
2. Two 1/2-inch steel bolts shall be provided for each current-transformer mounting position. Each bolt shall be furnished with a spring washer and a nut. The spring washer may be either split-ring washer installed with a flat washer or a conical (Belleville) washer. Bolts shall be secured in place and spaced as shown. All parts shall be plated to prevent corrosion.
Note : When conical washers are used, the manufacturer shall provide a readily visible label in the compartment clearly identifying the recommended torque setting for the bolt assemblies used with the washers.
3. Terminating positions for both load and line side conductors shall be aluminum-bodied mechanical lugs. The number and size of the mechanical lugs provided shall be sufficient to supply the service.
4. References:
 - a. For applications, see page 2-38.

**SERVICE AND METER PEDESTAL FOR COMMERCIAL SERVICES
200 AMPERES MAXIMUM**

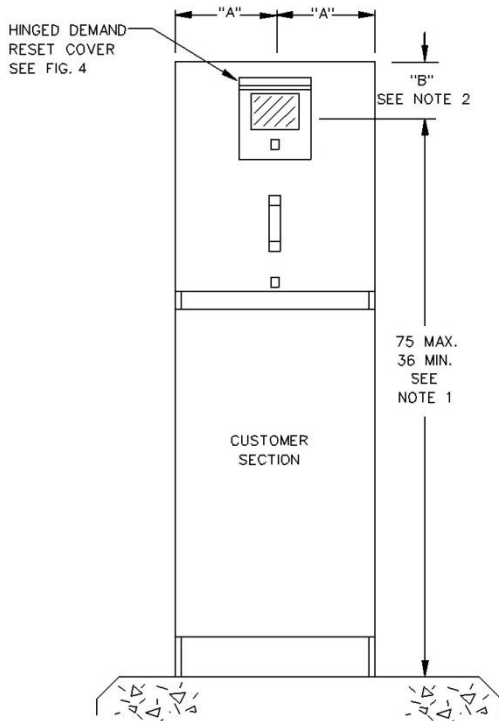

FRONT VIEW
FIG. 1

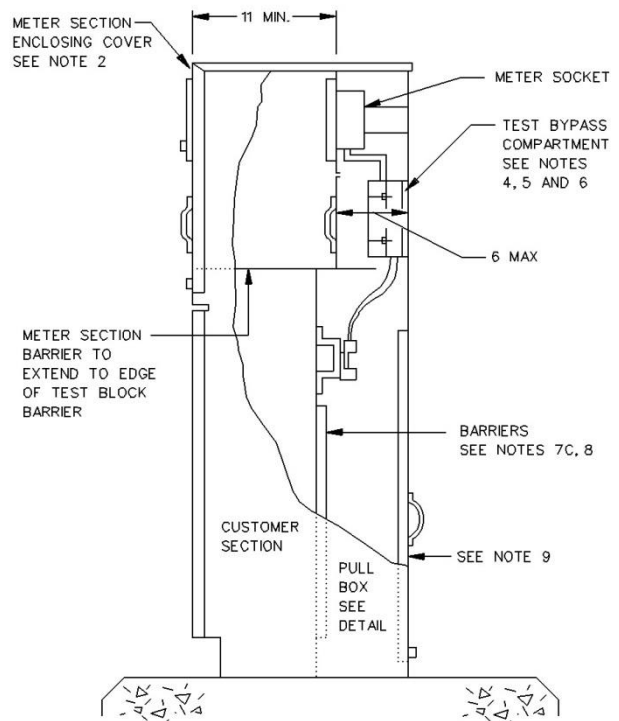

SIDE VIEW
FIG. 2

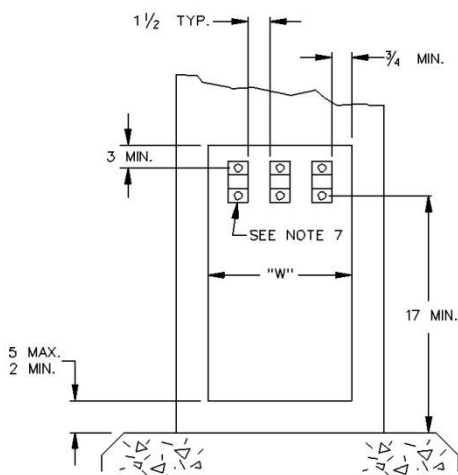

PULL SECTION DETAIL
SEE NOTES 6 AND 7
FIG. 3

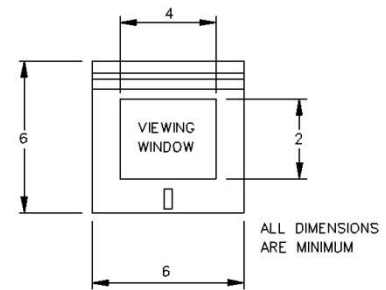

HINGED DEMAND RESET COVER DETAIL
WITH POLYCARBONATE VIEWING WINDOW
FIG. 4

MINIMUM DIMENSIONS

SERVICE TYPE	"W" SEE NOTE 7a	"A" SEE NOTE 2	"B" SEE NOTE 2
1Ø 3-WIRE			
3Ø 3-WIRE	10-1/2"	10"	4-1/2"
3Ø 4-WIRE	12-1/2"	10"	4-1/2"

SERVICE AND METER PEDESTAL FOR COMMERCIAL SERVICES (Cont.)**NOTES:**

1. The meter panel shall be provided with a sealing ring and the meter socket shall be rigidly mounted on a support and shall be attached to the meter panel. Meter height is measured from the center of the meter socket.
2. The meter shall be enclosed and the enclosing cover shall be:
 - a. Hinged to allow the top and front to be rotated back as one unit to expose the metering compartment. The "A" dimension applies when the meter compartment side panels are fixed in place and obstruct the meter socket side clearance. The lifting force to open the cover shall not exceed 25 pounds.
 - b. Equipped with a lifting handle.
 - c. Sealable and lockable with a padlock having a 5/16-inch lock shaft.
 - d. Provided with a demand reset cover with a viewing window (see Fig. 4). The reset cover shall be sealable and lockable with a padlock having a 5/16-inch lock shaft.
3. Test-bypass compartment covers shall be sealable and provided with a lifting handle. Covers exceeding 16 inches in width shall have two handles.
4. Test-bypass blocks with rigid insulating barriers shall be bussed or wired to the meter socket by the manufacturer and provided as follows:
 - a. For 1 \emptyset , 3-wire, provide two test-bypass blocks mounted in the outer positions and a 4-jaw socket. For 120/208 volts, 1 \emptyset 3-wire, provide two test-bypass blocks mounted in the outer positions and a 5-jaw meter socket - connect the 5th jaw of the meter socket to the insulated neutral terminal (see note 6) with a white No. 12 AWG (minimum) copper wire.
 - b. For 3 \emptyset , 3-wire, provide three test-bypass blocks and a 5-jaw meter socket - connect the line and load poles together at the top of the center position test-bypass block with a bus section and connect the bus to the 5th jaw of the meter socket with a No. 12 AWG (minimum) copper wire. The color used to identify the wire shall not be either white, gray, green or orange.
 - c. For 3 \emptyset , 4-wire, provide three test-bypass blocks and a 7-jaw meter socket - connect the 7th jaw of the meter socket to the insulated neutral terminal (see note 6) with a white No. 12 AWG (minimum) copper wire. For 120/240 volts, 4-wire delta, the right side test-bypass block shall be the power leg (measuring 208 volts-to-ground) and shall be identified with an orange color.
 - d. Test-bypass block connection sequence shall be LINE-LOAD from left to right and clearly labeled using 3/4-inch (minimum) block letters.
5. Test-bypass blocks shall be installed with the following minimum clearances:
 - a. 3-inches of vertical clearance from the upper test connector stud to the upper compartment access opening and 3 inches from the center of the cable terminal screw to the lower compartment access opening.
 - b. 1-1/2 inches of side clearance from the outer rigid insulating barriers to the compartment sides and 1-inch to the compartment access opening.

Date: 05-02-24

SERVICE AND METERING EQUIPMENT, 0 - 600 VOLTS**SERVICE AND METER PEDESTAL FOR COMMERCIAL SERVICES (Cont.)**

6. An insulated neutral terminal shall be provided behind the test-bypass cover panel for 1Ø 3-wire and 3Ø 4-wire meter sockets. The terminal shall be readily accessible when the cover panel is removed and shall be connected to the neutral terminating position in the pull section with a minimum size No. 8 AWG copper wire.
7. The terminating pull section shall:
 - a. Comply with the minimum dimensions shown in the table on sheet 1, be equipped with lifting handles, and accept a minimum 3-inch conduit. The "W" dimension is measured between the access opening return flanges.
 - b. Be equipped with aluminum-bodied, pressure-type lugs with range of No. 6 AWG through 250 KCMIL for termination of the service supply conductors. Insulated cable or bus shall be provided between the terminating lugs and the test-bypass facilities.
 - c. Have a protective metal barrier (16 gauge minimum) installed between the pull section and the customer section. The barrier shall provide a 1/4-inch minimum clearance between the customer section wall and the barrier to prevent damage by screws and bolts projecting into the pull section area.
8. The internal barrier between the pull section and customer section shall be constructed of metal (12 gauge minimum) and shall extend down to the concrete foundation. The barrier shall not be removable from the customer section.
9. The pull section cover shall be equipped with a lifting handle and be sealable and lockable with a padlock having a 5/16-inch lock shaft.
10. Photoelectric sensors and similar customer-owned devices shall not be installed in the pull section or metering compartment.
11. The pedestal shall be permanently labeled with the numeric portion of the address, in 1-inch high (minimum) numbers, on the exterior face of the meter cover or front portion of the pedestal.
12. Pedestal shall be mounted on a substantial concrete foundation.
13. For dual-socket pedestal designs, the ampacity of each service disconnect (meter switch) shall not exceed 100 amperes.
14. References:
 - a. For test-bypass blocks, see page 2-32.
 - b. For meter socket jaw arrangements, see page 2-5.
 - c. For sealing requirements, see page 2-9.
 - d. For lifting handle requirements, see page 2-9.
 - e. For general requirements, see page 2-8.

**THIS PAGE LEFT
INTENTIONALLY BLANK**

Date: 01-01-06

SERVICE AND METERING EQUIPMENT, 0 - 600 VOLTS

EUSERC DWG. 307

ALL DIMENSIONS SHOWN ARE IN INCHES

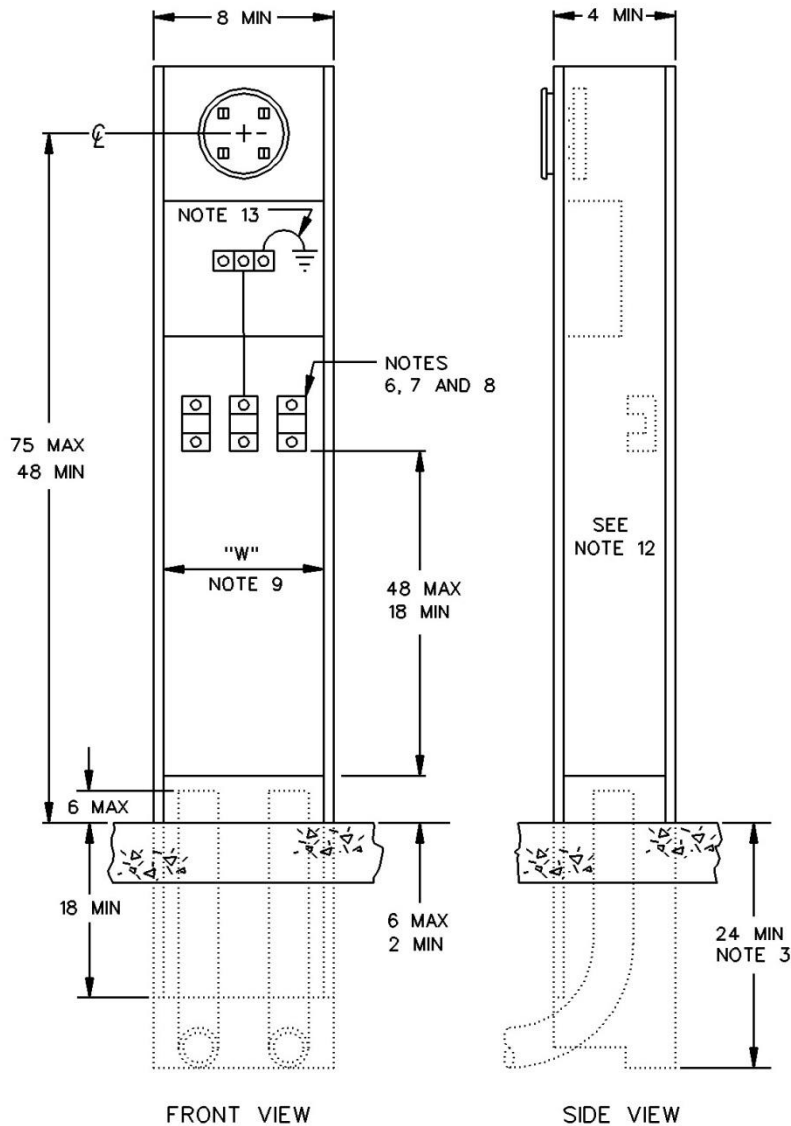
SERVICE AND METER POST FOR MOBILE HOME (TRAILER) SERVICES
200 AMPERES MAXIMUM, 240 VOLTS MAXIMUM 1Ø 3-WIRE

NOTES:

1. The meter socket shall have a minimum rating of 100 amperes and be provided with a complete rim and sealing ring. The meter socket shall be mounted on a support and be attached to the meter panel.
2. Factory installed conductors shall be provided from the meter socket to the cable terminating facilities and shall be connected in the terminating lugs independently of the service supply conductors.
3. The minimum depth of the post in the ground shall be 24 inches with openings at the base to permit the service supply conduit to sweep into the post from the front (meter side).
4. The fixed panel shall extend 2 inches minimum to 6 inches maximum above grade and 18 inches minimum below grade.
5. The meter disconnect and power outlet section shall be barred to prevent access to unmetred conductors.
6. The service supply cable terminating facilities shall be No. 2 AWG through No. 350 KCMIL aluminum-bodied, pressure-type lugs. Terminating lugs may be positioned either in line or staggered and access shall be unobstructed when all service conductors are in place.
7. A minimum clearance of 1-1/2 inches shall be provided between lugs, from lugs to any grounded surface, or from lugs to the panel above. Rigid insulated barriers are required and shall project a minimum of 1/4 inch beyond any energized parts when these clearances are reduced.
8. The neutral terminating facility shall be identified.
9. The pull section access opening (W) shall be a minimum of 7-1/2 inches in width.
10. The pull section cover shall be sealable and shall extend from the top of the fixed panel to the bottom of the power outlet section.

SERVICE AND METER POST FOR MOBILE HOME(TRAILER) SERVICES (Cont.)

11. No customer load conductors or grounding conductors shall be installed in, or pass through, the pull section.
12. The pedestal shall be installed vertically and plumb.
13. An accessible equipment grounding lug shall be provided.
14. References:
 - a. For sealing requirements, see page 2-9.
 - b. For lifting handle requirements, see page 2-9.

Date: 01-01-04

SERVICE AND METERING EQUIPMENT, 0 - 600 VOLTS

**THIS PAGE LEFT
INTENTIONALLY BLANK**

LOW-VOLTAGE SWITCHBOARDS, 0 - 600 VOLTSDate: 05-02-24

CONTENTS

	<u>PAGE</u>
A. Manufacturer's Drawings for Approval	3-3
B. Switchboard Service Sections	3-3
1. General	3-3
2. Instrument-Transformer Compartments	3-4
3. Meter Panels	3-4
4. Barriers	3-4
C. Meter Sockets	3-5
1. General	3-5
2. Customer-Installed Protective Devices	3-5
D. Totalized Metering	3-6
E. Meter Wiring Raceway	3-6
F. Meter Sequence	3-6
G. Service Disconnects	3-7
1. Meter Switches	3-7
a. General	3-7
b. Locking Provisions	3-7
2. Service Main Switches for Multiple-Metering	3-8
a. General	3-8
b. Locking Provisions	3-8
3. Permissible Ampacity	3-8
a. Single-Phase Service	3-8
b. Three-Phase Service	3-8
H. Underground Service Terminating Pull Sections	3-9
a. General	3-9
b. Locations and Working Space	3-9
I. Lifting Handles	3-10
J. Sealing Requirements	3-10
K. Grounding and Bonding	3-10
L. Labeling Requirements	3-11
M. Ventilation Openings	3-11
Illustrations:	
Standard Switchboard Service (Metering) Section with Instrument-Transformer Compartment	3-12
Standard Switchboard Service (Metering) Section with Instrument-Transformer Compartment and Filler Panel	3-14
15-inch Hinged Meter Panel	3-16
30-inch Hinged Meter Panel for Totalized Switchboard installations	3-18

CONTENTS (Cont.)

	<u>PAGE</u>
Instrument-Transformer Compartments:	
1Ø, 3-Wire, 400-1000 Amperes	3-20
3Ø, 3-Wire and 4-Wire, 400-1000 Amperes	3-22
1Ø, 3-Wire, 240 Volts, 1001-3000 Amperes	3-24
3Ø, 3-Wire and 4-Wire, 1001-3000 Amperes	3-26
3Ø, 3-Wire and 4-Wire, Exceeding 3000 Amperes	3-28
Removable Link with Current-Transformer Support for:	
Single- Bolt Mounting Pattern for 4-inch Bus	3-30
Two-Bolt Mounting Pattern for 5-inch Bus	3-32
Self-Contained Meters with Test-Bypass Blocks in Switchboards	3-34
Required Clearances on Typical Residential Multiple-Metering Arrangement	3-36
Outdoor or Raintight Enclosures for Switchboards	3-38
Typical Switchboard Termination Arrangements for Overhead Supply	3-40
Typical Switchboard Termination Arrangements for Underground Supply	3-42
Standard Terminating Pull Section, Bottom Entry	3-44
Nonstandard Terminating Pull Section for Below Ground Level Installations	3-46
Busway Service Heads	3-48

LOW-VOLTAGE SWITCHBOARDS, 0 - 600 VOLTSDate: 10-01-25

A. MANUFACTURER'S DRAWINGS FOR APPROVAL

1. Customers are required to consult the Department regarding all new switchboard installations and changes in metering due to load additions or modifications to existing services.
2. The Department recommends that manufacturers submit drawings for any proposed switchboard sections to the Department for review to determine whether the proposed equipment is correctly designed for the application committed to the customer. **However, manufacturers shall submit equipment drawings to the Department before fabricating the following equipment:**
 - a. All **standard** switchboard service sections manufactured to meet the Department's current published requirements (See pages 3-12 and 3-14 for typical metering arrangements).
Exception: Service sections rated up to 800 amperes that are mass produced and sold as warehouse items do not require a switchboard drawing submittal.
 - b. All **non-standard** (not specifically covered in these requirements) switchboard metering sections and pull sections.
Note: Submittals by manufacturers for approval of non-standard service equipment arrangements shall be clearly identified as requests for variance. The areas of non-compliance shall be clearly identified along with justifications for the variance request.
 - c. All busway service heads (See page 3-48 for construction details).
3. Drawings shall provide the following information:
 - a. Job Address (not delivery address).
 - b. Manufacturer's contact with email address, telephone and fax number.
 - c. Voltage, ampacity and short-circuit rating information.
 - d. Details of the equipment with panel layout, sectional view layout and dimensions; meter socket arrangements, and appropriate ESR or EUSERC page references. Single-line type drawings are not acceptable.
 - e. Any other information deemed necessary for approval of the drawing.
4. Email copies of the switchboard drawings to the Service Planning, Customer Station Design, Electric Vehicle Design or PV/BESS Design office (Attention: Switchboard Review) located in the area where the service is to be supplied. See page 1-4 for office locations, telephone numbers, and PAGE 1-5 for service planning area boundaries. Note: Customer Station, Electric Vehicle, and PV/BESS Design groups do not have area maps and handle projects throughout the City and in the Owens Valley.
5. Questions regarding drawing status should be made to the Service Planning office where the drawings are submitted.
6. Switchboard approvals shall remain in effect for no more than 18 months after which time new drawings shall be resubmitted for approval.

B. SWITCHBOARD SERVICE SECTIONS**1. GENERAL**

- a. A standard switchboard service section is a floor standing, metal enclosure intended for the termination of the service entrance conductors or station supply conductors. It shall be provided with panels for meters and secondary test switches, an instrument-transformer compartment and may contain the meter switch.
- b. Service entrance conductors and station service supply conductors shall normally enter the top of the section and shall leave below the bottom of the instrument-transformer compartment.

B. SWITCHBOARD SERVICE SECTIONS (Cont.)**1. GENERAL (Cont.)**

- c. No conductors other than the standard service bussing specified in these requirements shall be installed in, or routed through, the instrument-transformer compartment.

2. INSTRUMENT-TRANSFORMER COMPARTMENTS

- a. An instrument-transformer compartment is required when:
 - (1) The meter switch exceeds 400 amperes for residential services.
 - (2) The meter switch exceeds 200 amperes for commercial and industrial services.
 - (3) The service voltage exceeds 600 volts.
- b. Instrument-transformer compartments shall have provisions for the installation of current-transformers, test switches and meters. For bus arrangements and dimensions, see pages 3-12 through 3-14.
- c. Except for factory-installed cross bussing and service entrance conductors supplying instrument-transformer compartments, no other conductors or devices shall be installed in, or routed through, any instrument-transformer compartment or in the sealed area above the compartment.

3. METER PANELS**a. SELF-CONTAINED METERS**

Meter panels as shown on Pages 3-34 and 3-36 will be provided. The removable panel and channel for test-bypass blocks may be omitted for residential multi-meter services where each occupancy is separately metered.

b. METERS WITH INSTRUMENT TRANSFORMERS

- (1) Hinged meter panels with provisions for the installation of socket type meters and secondary test switches shall be furnished by the switchboard manufacturer as specified on Pages 3-16 and 3-18.
- (2) Hinged meter panels shall be capable of being opened to 90 degrees with the meter and test switch in place. The following clearances shall be provided from the socket meter panel to any obstruction:
 - (a) 11 inches at the meter socket.
 - (b) 4 inches at the test switch slot.

4. BARRIERS

- a. When more than one switchboard section is installed, each service section shall be completely barriered from other service sections, pull sections or service switches. Barriers may have openings to allow passage of un-metered conductors between sections.

Note: The clearance between bus bars and glastic barrier shall be a maximum of 3 inches. No barrier shall be required between individual phase busses and the neutral bus.

LOW-VOLTAGE SWITCHBOARDS, 0 - 600 VOLTSDate: 05-02-24

B. SWITCHBOARD SERVICE SECTIONS (Cont.)

- b. Barriers used to separate customer sections from utility sections (i.e., pull sections and metering sections) and sections containing unmetered conductors or bus shall be constructed from 16-gauge (minimum) steel and shall be secured with devices (carriage bolts or equivalent) that are not removable from either the customer sections or the exterior of the switchboard.

Exception: The barrier between sealed utility metering sections and the terminating pull section may be 1/8" minimum glastic or equivalent.

- c. Where an instrument-transformer compartment is supplied by cabling provided from an adjacent pull section, an opening shall be provided in the barrier between the sections above the instrument-transformer compartment. The bottom edge of the opening shall be rolled to protect the conductors from damage.
- d. Where a load wireway is equipped with unmetered cross bussing the cross bussing shall be barriered to isolate the bus from the customer's load conductors.

C. METER SOCKETS**1. GENERAL**

- a. Every new switchboard installation shall be equipped with a meter socket (without bypass devices) and an approved sealing ring. Sockets shall have the jaw arrangement specified for the voltage and phase to be metered. See page 2-5 for socket jaw arrangements.
- b. Meter sockets shall be provided with jaws or clips of beryllium copper, be listed by Underwriters Laboratories (UL) and conform to ANSI Standard C12.7.
- c. Self-contained meters shall be attached to a rigid stationary support and be attached to the meter panel to assure alignment of the socket ring to the socket jaws and to prevent removal of the panel with the meter installed.
- d. Instrument-transformer rated sockets shall be designed for back connection. Sockets shall be installed with machine screws so the socket can be easily interchanged or replaced.
Note: Screws used to mount cast meter sockets to meter panels shall provide a 1/8" minimum clearance between the screw head and the back of the meter socket ring.
- e. Ringless or gasketed type metered sockets are not permitted.
- f. All meter fittings shall be mounted on a substantial support in a true vertical position.
- g. For commercial and industrial multi-meter installations, no more than two meters may be mounted on a single removable panel unless the design permits replacement of individual meter sockets without disturbing adjacent meters secured with sealing or locking rings.
- h. For residential multi-meter installations, no more than one meter may be mounted on a single removable panel unless the design permits replacement of individual meter sockets without disturbing adjacent meters secured with sealing or locking rings.
- i. Meter sockets in multi-meter installations shall be clearly and permanently identified with the address it serves, as specified by the Department.

2. CUSTOMER-OWNED DEVICES

Customer-owned adapters, automatic or manual transfer switches, surge-arrestors, fuses, breakers or other devices shall not be installed between the meter socket and the Department's electric meter.

Date: 05-02-24

LOW-VOLTAGE SWITCHBOARDS, 0 - 600 VOLTS

D. TOTALIZED METERING

1. While the Department is not required to provide totalized metering for the customer's convenience, requests for totalizing will be considered on an individual basis. Totalizing is limited to instrument-rated switchboard installations.
2. Where the Department provides totalized metering for the customer's convenience, the customer shall reimburse the Department for the Department's estimated cost of the totalized service exceeding the cost of a standard (not totalized) metering installation.
3. Metering sections to be totalized shall be in the same room or at an adjacent location with access provided through a doorway not less than 30 inches wide and 6 feet - 6 inches high.
4. Each metering section to be totalized shall be provided with a separate underground terminating enclosure or overhead wiring raceway. For overhead services, see page 7-15, **SERVICE HEADS-LOCATIONS**, for spacing requirements.
5. Metering sections to be totalized shall be provided with a secondary wiring enclosure between the sections. See **METER WIRING RACEWAY** for additional requirements.

E. METER WIRING RACEWAY

1. A wiring raceway shall be installed between:
 - a. A remote meter panel and its related instrument-transformer compartment.
 - b. Instrument-transformer compartments that are to be totalized.
Note: The wiring raceway between metering sections to be totalized shall not exceed 40 feet in length.
2. The wiring raceway shall consist of either a single rigid conduit, or electric metallic tubing of 1-inch (minimum) trade size or a sealable raceway.
3. The wiring raceway shall enter the top of the instrument-transformer compartment within 3 inches of the front of the compartment and within 3 inches of either side of the compartment. Adjacent compartments may be connected by a 1-inch chase nipple at the same level and in front of the upper support bar.
4. A standard doorway shall be provided between totalized instrument-transformer compartments or between an instrument-transformer compartment and its related (remote) meter socket.

F. METER SEQUENCE

1. Every single meter socket shall be installed on the line side of its related meter switch (HOT SEQUENCE).
2. For multiple meter installations where a service main switch is required or permitted on the line side of the meter sockets (COLD SEQUENCE), the switch shall be located adjacent to its related meter sockets.

Exception: For large multi-story buildings or other installations where the Department has approved meters in multiple or remote locations and the Permitting Authority has required a (controlling) service disconnect device at the source location to protect the service entrance conductors, the adjacent disconnect device at the remote meter location is not required provided:

LOW-VOLTAGE SWITCHBOARDS, 0 - 600 VOLTSDate: 05-02-24

F. METER SEQUENCE (Cont.)

- a. The meter switch or service main switch for the metering equipment shall control all electric load to a specific area and is labeled to indicate the controlled area (i.e., occupancy, load served, etc.)
 - b. The metering equipment is located in a publicly accessible area and is labeled to clearly identify the controlling service switch and its location.
 - c. The controlling service switch is capable of being locked in the open position.
3. To prevent energy diversion, unmetred runs of service entrance conductors supplying remote meter location shall be enclosed in an unbroken conduit run. The Department reserves the right to inspect these conduit runs during and subsequent to the installation.

Exception: Pull boxes, condulets and LB condulets when required by the permitting agency for cable support or pulling needs shall be installed in meter rooms, sealable, clearly identified and readily accessible. Lifting handles shall be provided where required by the Department. Condulets and LB condulets installed in other locations require approval of the Department prior to installation.

G. SERVICE DISCONNECTS**1. METER SWITCHES****a. GENERAL**

- (1) The customer shall furnish and install a service disconnect device (meter switch) such as a circuit breaker, fused switch or other approved disconnect device with overcurrent protection on the load side of each and every meter (HOT SEQUENCE).
- (2) The meter switch shall control all of, and only, the energy registered by the meter.
- (3) When separate switchboard service sections are totalized, a meter switch will be required for each service section.
- (4) When approved by the AHJ, the meter switch may consist of a group of up to six separate disconnect devices grouped at a single location. See "Rating" page 2-6.
- (5) The meter switch shall be fully accessible and located directly adjacent to its associated meter unless otherwise approved by the Department.

Note: For single family residences and duplexes, the meter switch shall also be located outdoors.

b. LOCKING PROVISIONS

Meter switches provided for instrument-transformer compartments shall be capable of being locked in the open (off) position using a standard Department padlock having a 5/16-inch lock shaft and a 1-inch locking clearance. Locking provisions shall consist of:

- (1) A lockout device that is incorporated as an integral part of each meter switch, or
- (2) A lockable cover for each meter switch where the lock prevents operation of the switch and prevents removal of the cover, or
- (3) A lockable cover for multiple meter switches supplied from a single instrument-transformer compartment where the lock prevents operation of the switch and prevents removal of the cover.

Note: Each of the alternate locking provisions described above may be accomplished up to two (2) padlocks per meter switch. Where two padlocks are required to lock a meter switch in the open position, the locking points shall be readily identifiable.

Date: 11-18-24

LOW-VOLTAGE SWITCHBOARDS, 0 - 600 VOLTS

G. SERVICE DISCONNECTS (Cont.)

- (4) For fused switches, the fuse access cover shall be lockable when the switch is locked in the open (off) position.

Exception: Switches that do not allow access from the fuse compartment to the energized (hot) side of the switch.

2. SERVICE MAIN SWITCHES FOR MULTIPLE METERING**a. GENERAL**

- (1) A service main switch shall consist of either a circuit breaker, fused disconnect, or other approved disconnecting means located on the line side (COLD SEQUENCE) of its group of related meters.

Note: A main service switch shall not be installed on the line side of a single meter socket.

- (2) Auxiliary equipment related to the service main switch shall be fully located within the switch cabinet or compartment and only equipment required by the AHJ for Code compliance shall be approved. The devices will need to be barriered such that they are not contained in the utility sealed section and maintenance can be done without needing to open the utility sealed section. Power supplies for auxiliary equipment shall be fed from a metered source.

- (3) A service main switch shall be located in a meter room or meter area, unless otherwise approved by the Department.

b. LOCKING PROVISIONS

- (1) The service main switch shall be required to be lockable in the open (off) position when:
- (a) The service main disconnect is not adjacent to (i.e., within reasonable proximity and line of sight) its related group of meters, or
 - (b) Otherwise specified by the Department.
- (2) Locking provisions shall consist of:
- (a) A lockout device that is incorporated as an integral part of each meter switch, or
 - (b) A lockable cover for the service switch where the lock prevents operation of the switch and prevents removal of the cover.

3. PERMISSIBLE AMPACITY**a. SINGLE-PHASE SERVICE**

A single-phase service shall not supply a service switch in excess of 600 amperes, 120/240 volt, three-wire. Where a switch of greater ampacity is required, the Department's approval must be obtained as to the required number of sets of service entrance conductors, load balance, and related metering facilities prior to supplying service.

b. THREE-PHASE SERVICE

In general, there is no limit to the ampacity of a service switch for a three-phase service. Only a single service with a single set of metering equipment for the entire load will be permitted at any service location. When the anticipated load requires a switch exceeding 5000 amperes, the Department shall be consulted for engineering information prior to designing the installation.

H. UNDERGROUND SERVICE TERMINATING PULL SECTIONS**1. GENERAL**

- a. Underground service supply conduits installed from the Department's underground electric system (or pole dips from the overhead electric system) to the customer's metering equipment shall terminate in an approved underground terminating enclosure. For approved terminating enclosure arrangements, see pages 2-13, 2-14, 3-44 and 3-46.

CAUTION: Service supply conduits shall not enter any terminating enclosure above either the cable terminating facilities or other energized bussing. Terminating enclosures shall be located so that any moisture entering the enclosure from the service conduits will not enter the customer's service equipment.

- b. For services rated up to 2000 amperes, the service supply conduits may enter either the bottom or back of the switchboard pull section - see page 3-46 for details and restrictions on back-entry conduit. For services exceeding 2000 amperes, the service supply conduits shall enter the bottom.

Note: Special termination enclosure arrangements must be approved by the Department before installing any facilities.

- c. Except for the Department's service supply conductors and the customer's service entrance conductors, no other conductors or devices (i.e., fuses, surge arrestors, current-transformers and other customer-owned wiring or devices) shall be installed in, or routed through, any underground pull section enclosure.

2. LOCATIONS AND WORKING SPACE

- a. The service terminating pull section shall be readily accessible and located on the exterior wall of a building or other approved permanent structure, in an approved meter room on the first floor or basement parking level or other locations as the Department may designate.

Note: When it is necessary to locate the service below grade level and it is fed by either a substructure or a pole, a double terminated pull section shall be required at grade level to prevent water intrusion into the electrical room. A means of service disconnect shall not be allowed with this pull section unless it is also located adjacent to its related meter socket(s). Consult the Department for specific requirements.

- b. Pull section locations prohibited:

- (1) In any meter room, storage room or basement area in any single-family dwelling.

Note: Pull sections shall be located to be accessible without entering any building.

- (2) In any occupancy of any multiple-tenant building.

- (3) In any rest, bath, toilet, shower, dressing room or in any room accessed through such areas.

- (4) In any hazardous location.

- (5) In any other location judged unacceptable to the Department.

- c. Pull sections shall be provided with a level, unobstructed working space in front of the entire pull section. The minimum required working space shall be 3 feet in width, extend 3 feet from the front of the pull section, and extend to the top of the section but not less than 6 feet - 6 inches.

Date: 05-05-24

LOW-VOLTAGE SWITCHBOARDS, 0 - 600 VOLTS

I. LIFTING HANDLES

1. Removable cover panels shall be equipped with a lifting handle. Cover panels in excess of 3 square feet shall require two lifting handles. The handles shall be located so as to provide control and balance while the panel is being removed.
2. Hinged meter panels shall be equipped with a handle on the side opposite the hinges.
3. Handles shall be sized for full-hand grasping, securely attached, and have strength to withstand handling stresses of not less than 75 pounds. Folding or hinged handles are not acceptable.

J. SEALING REQUIREMENTS

1. All removable panels providing access to compartments containing unmetred conductors shall be sealable including customer load wireways. No removable panel or cover requiring sealing shall be located behind any other panel, cover or door (except raintight enclosure doors).
2. Sealable latches, captive stud assemblies, or sealing screws may be used for sealing and shall be installed so as to prevent a sealed cover from being opened or removed without breaking the seal.
3. Non-hinged removable covers shall be sealed with captive stud assemblies on opposite sides of the cover. Alternate sealing methods may be used if the removable cover is self-supporting with the securing screws and sealing provisions removed.
4. Hinged covers or panels shall be sealed on the side opposite the hinges.
5. Captive stud assemblies shall consist of a 1/4-inch-20 (minimum) stud, and associated wing-nut, each drilled 0.0635 inch (minimum) for sealing purposes. The stud shall be securely attached so as to not loosen or back out when being fastened.

K. GROUNDING AND BONDING**1. GROUNDING**

- a. Manufacturers shall not provide a termination lug for the customer's grounding conductor in any compartment sealed or locked by the Department.

Exceptions: A grounding terminal is permitted in a main service switch compartment or, when required by the permitting agency for services supplied overhead, in a sealed wireway used to supply more than one meter socket.

- b. Where busway having an integral or internal ground is used to supply an instrument-transformer compartment, a ground bus (not cable) shall be permitted to pass through the compartment for connection to the busway grounding provision provided it is located at the side or rear of the compartment and does not infringe on any of the specified bus or working space clearances.
- c. The grounding electrode conductor shall not be installed in, or routed through, any compartment sealed or locked by the Department.

LOW-VOLTAGE SWITCHBOARDS, 0 - 600 VOLTSDate: 05-02-24

K. GROUNDING AND BONDING (Cont.)**2. BONDING**

- a. Ground bus units installed by manufacturers to provide bonding between equipment sections are permitted in compartments sealed or locked by the Department. Ground bus units provided in underground terminating pull sections shall be located in the rear of the compartment. See item 1 under "Grounding" regarding placement of the terminal lug for the customer's ground conductor.
- b. Conduit bonding jumpers shall be terminated at the closest available point where the conduit to be bonded enters an underground terminating enclosure or metering compartment.

L. LABELING REQUIREMENTS (Manufacturer)

1. Meter and service equipment shall be provided with a manufacturer's label identifying the metered voltage, phase, ampacity and rated short-circuit duty (when applicable).
2. Meter and service equipment shall be provided with a label identifying the nationally recognized testing laboratory (NRTL) that has tested and listed the equipment.
3. Multi-voltage rated service and metering equipment shall be identified with the metered voltage.

M. VENTILATION OPENINGS

1. Ventilation openings in weatherproof (NEMA-3R) rated panel covers with provision for utility seals shall be protected by internal intrusion resistant metal barriers that are secured with devices that may not be removed from the outside.
2. Filters for ventilation openings (if so equipped) shall be serviceable by the customer without the need to remove utility locks or break utility seals.

**STANDARD SWITCHBOARD SERVICE SECTION
WITH INSTRUMENT-TRANSFORMER COMPARTMENT**

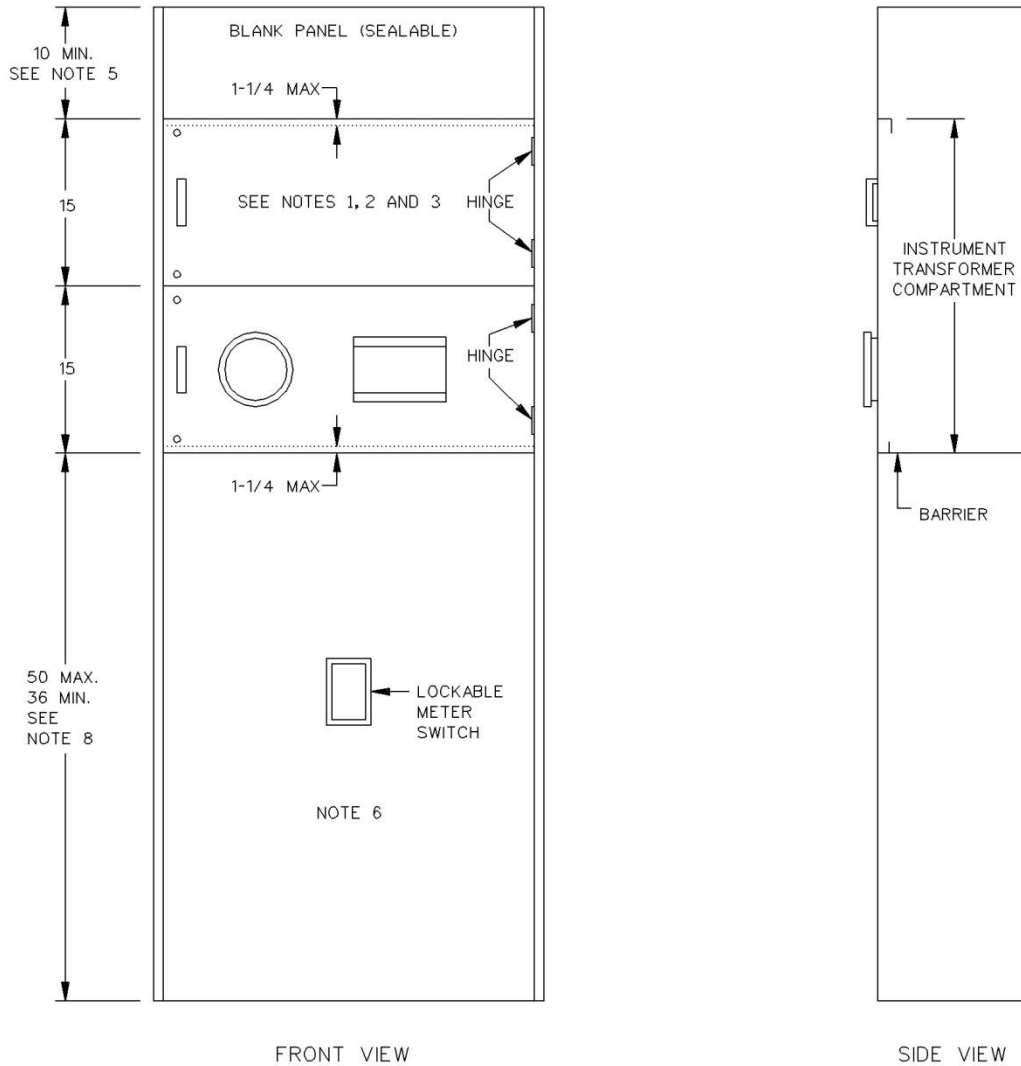

NOTES:

1. The socket meter panel and the blank panel shall be hinged on the same side, either left or right, so they open in the same direction.
Note: The meter socket panel shall be provided by the manufacturer hinged on the test switch side.
2. Hinges shall be readily interchangeable to either the left side or right side access opening return flanges.
3. Hinged panels shall be equipped with stops to prevent inward swinging beyond the surface of the service section.

STANDARD SWITCHBOARD SERVICE SECTION (Cont.)

4. Removable or hinged panels enclosing unmetered bus or cable shall be sealable.
5. Dimension may be reduced if the service section is supplied from horizontal cross bussing or bus duct.
6. Compartment may be used as an underground pull section for termination of the Department's service supply conductors in a bottom feed service section.
7. The customer's grounding connection shall be located in the customer's load section. No grounding conductor or conduit shall be routed through the instrument-transformer compartment or in the pull section when constructed as a bottom-feed service section.
8. Dimension measured from the top surface of the horizontal barrier.
9. References:
 - a. For instrument-transformer compartments:
 - (1) 1 \emptyset and 3 \emptyset , 3-wire: 400-1000 amperes, see page 3-20.
1001-3000 amperes, see page 3-24.
 - (2) 3 \emptyset , 3-wire and 4-wire: 400-1000 amperes, see page 3-22.
1001-3000 amperes, see page 3-26.
3001 amperes and above, see page 3-28.
 - b. For sealing requirements, see page 3-10.
 - c. For lifting handle requirements, see page 3-10.
 - d. For meter disconnect locking requirements, see page 3-7.
 - e. For socket meter panel requirements, see pages 3-16 and 3-18.
 - f. For weatherproof (NEMA-3R) enclosure requirements, see page 3-38.
 - g. For pull section requirements for a bottom-feed service section, see page 3-44.
 - h. For barrier requirements, see page 3-4.

**STANDARD SWITCHBOARD SERVICE SECTION
WITH INSTRUMENT-TRANSFORMER COMPARTMENT AND FILLER PANEL**

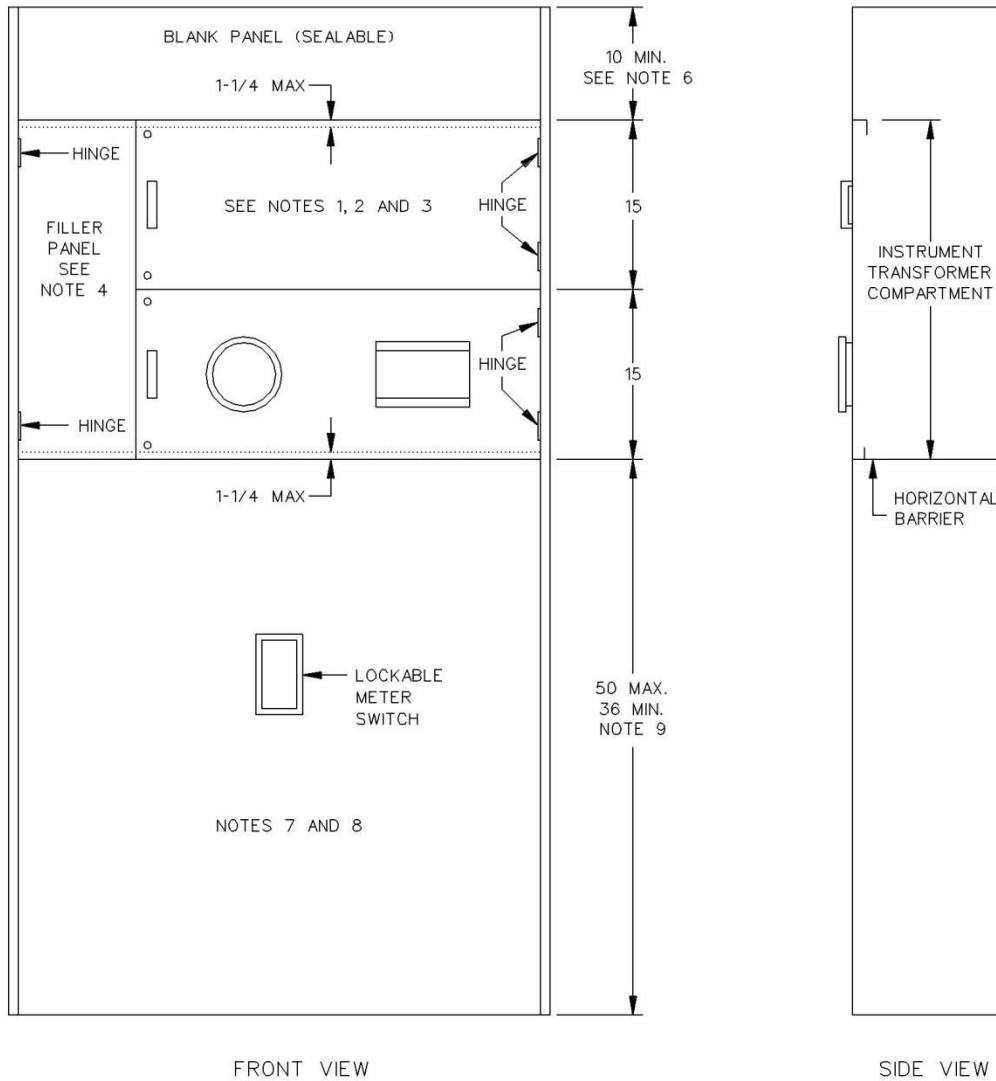

FRONT VIEW

SIDE VIEW

NOTES:

1. The socket meter panel and the blank panel shall be hinged on the same side, either left or right, so they open in the same direction.

Note: The meter socket panel shall be provided by the manufacturer hinged on the test switch side.

2. Hinges shall be readily interchangeable to either the left side or right side access opening return flanges.

3. Hinged panels shall be equipped with stops to prevent inward swinging beyond the surface of the service section.

STANDARD SWITCHBOARD SERVICE SECTION (Cont.)

4. A hinged filler panel is required when the switchboard frame width exceeds the maximum allowable meter panel width. Meter panels, either socket type or blank, shall not be hinged to a hinged filler panel. Non-hinged filler panels shall not intrude into the required instrument-transformer compartment clearances.
5. Removable or hinged panels enclosing unmetered bus or cable shall be sealable.
6. Dimension may be reduced if the service section is supplied from horizontal cross bussing or bus duct.
7. Compartment may be used as an underground pull section for termination of the Department's service supply conductors in a bottom feed service section.
8. The customer's grounding connection shall be located in the customer's load section. No grounding conductor or conduit shall be routed through the instrument-transformer compartment or in the pull section when constructed as a bottom-feed service section.
9. Dimension measured from the top surface of the horizontal barrier.
10. References:
 - a. For instrument-transformer compartments:
 - (1) 1 \emptyset and 3 \emptyset , 3-wire: 400-1000 amperes, see page 3-20.
1001-3000 amperes, see page 3-24.
 - (2) 3 \emptyset , 3-wire and 4-wire: 400-1000 amperes, see page 3-22.
1001-3000 amperes, see page 3-26.
3001 amperes and above, see page 3-28.
 - b. For sealing requirements, see page 3-10
 - c. For lifting handle requirements, see page 3-10.
 - d. For meter disconnect locking requirements, see page 3-7.
 - e. For socket meter panel requirements, see pages 3-16 and 3-18.
 - f. For weatherproof (NEMA-3R) enclosure requirements, see page 3-38.
 - g. For pull section requirements for a bottom-feed service section, see page 3-44.
 - h. For barrier requirements, see page 3-4.

15-INCH HINGED METER PANEL

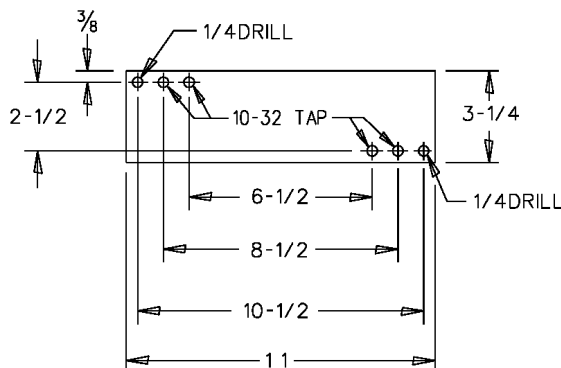
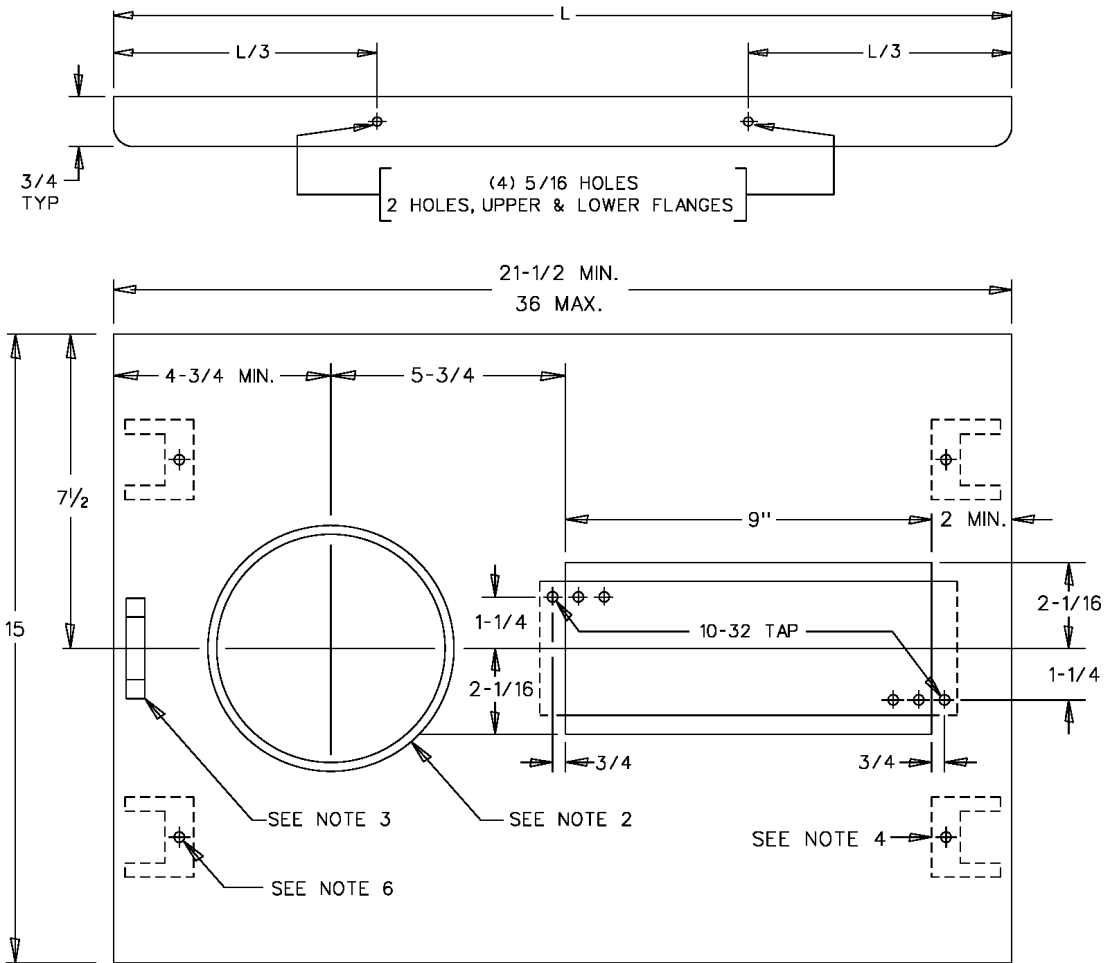

REMOVABLE (TEST SWITCH)
MOUNTING PLATE DETAIL

15-INCH HINGED METER PANEL (Cont.)**NOTES:**

1. A standard metering installation shall consist of a hinged socket meter panel in the lower position and a hinged panel blank (not shown) in the upper position. The panels shall be constructed of 12-gauge (minimum) steel and installed so that both panels open in the same direction.
2. The socket meter panel shall be furnished with a meter ring, meter socket, sealing ring and a slotted opening with a removable plate for installation of a test switch. The plate shall be attached to the rear of the panel with screws that do not protrude through the face of the panel and the edges of the plate and the slotted opening shall be smooth to prevent damage to the meter wiring.
Note: Screws used to mount cast meter sockets to meter panels shall provide a 1/8" minimum clearance between the screw head and the back of the meter socket ring.
3. The panels shall have a handle at the unsupported end. The handle on the socket meter panel shall be readily interchangeable, left to right side, and shall be located not less than 1 inch from the meter socket ring.
4. The hinges shall permit the panels to open to 90-degrees or more. The hinges on the socket meter panel shall be readily interchangeable, left to right side. Clevis or removable pin type hinges shall be removable from the top.
5. The panels shall support a 25-pound force applied at the unsupported end of the panels, when fully opened, with a maximum sag of 1/8 inch.
6. Meter panels shall be sealable on the side opposite the hinges using either sealing screws or stud and wing-nut assemblies.
7. References:
 - a. For meter panel applications, see pages 3-12 and 3-14.
 - b. For meter socket jaw arrangements, see page 2-5.
 - c. For sealing requirements, see page 3-10.
 - d. For lifting handle requirements, see page 3-10.

30-INCH HINGED METER PANEL FOR TOTALIZED SWITCHBOARD INSTALLATIONS (Cont.)

3. The panel shall be furnished with a meter ring, meter socket, sealing ring and a slotted opening with a removable plate for installation of a meter test switch. The plate shall be attached to the rear of the panel with screws that do not protrude through the face of the panel and the edges of the plate and the edges of the slotted opening shall be smooth to prevent damage to meter wiring.

Note: Screws used to mount cast meter sockets to meter panels shall provide a 1/8" minimum clearance between the screw head and the back of the meter socket ring.

4. The panel shall have a handle attached to both sides. The handle shall not be less than 1 inch from the meter socket ring.
5. The hinges shall be readily interchangeable, left to right side, on the panel and permit the panel to open to 90-degrees or more. Clevis or removable pin type hinges shall be removable from the top.
6. The panel shall support a 25-pound force applied at the unsupported end of the panel when fully opened with maximum sag of 1/8 inch.
7. The panel shall be sealable using either sealing screws or stud and wing-nut assemblies.
8. Totalized metering arrangements may no longer be available for new or upgraded services, contact the Department for details.
9. References:
 - a. For meter panel applications, see pages 3-12 and 3-14.
 - b. For meter socket jaw arrangements, see page 2-5.
 - c. For sealing requirements, see page 3-10.
 - d. For lifting handle requirements, see page 3-10.

INSTRUMENT-TRANSFORMER COMPARTMENT FOR SWITCHBOARDS
400-1000 AMPERES, 1Ø 3-WIRE AND 3Ø 3-WIRE (See Note 9)

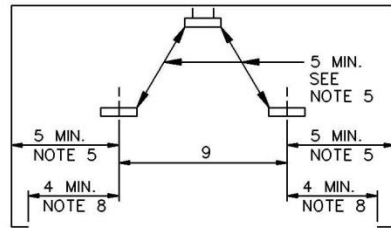

TOP VIEW

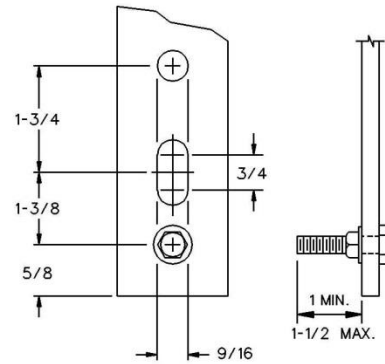

BUS DRILLING DETAIL - TYPICAL 4 LOCATIONS
SEE NOTE 3

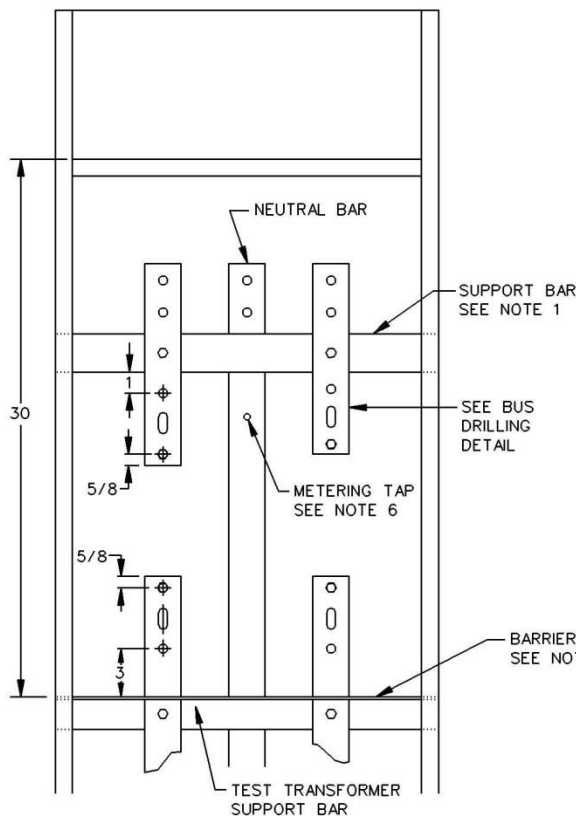

FRONT VIEW

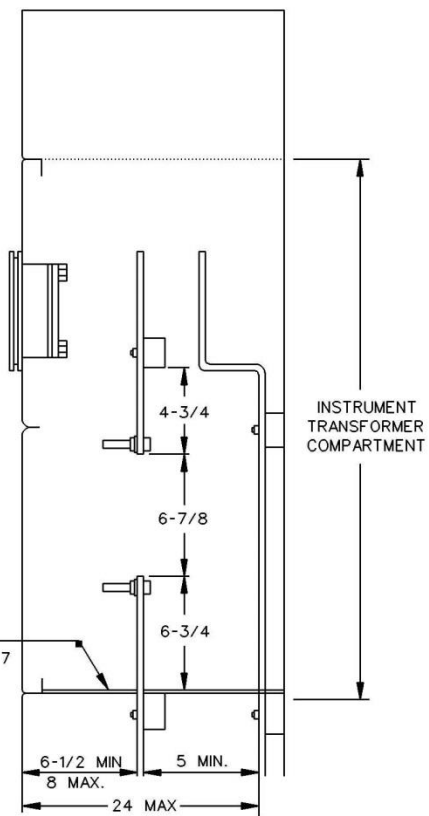

SIDE VIEW

NOTES:

1. Bus arrangements and supports shall be provided as shown, except the neutral bus may be located on either sidewall or at either side. Bus supports shall be constructed of a continuous bar of non-conducting material and shall be rigid to prevent misalignment of the bus units with the cables installed.

LOW-VOLTAGE SWITCHBOARDS, 0 - 600 VOLTSDate: 05-02-24

INSTRUMENT-TRANSFORMER COMPARTMENT FOR SWITCHBOARDS (Cont.)
400-1000 AMPERES, 1Ø 3-WIRE AND 3Ø 3-WIRE

2. The current-transformer bus units may be supplied from either the top or the bottom and shall be anchored to prevent misalignment. The bus units shall be constructed of rectangular bus and when laminated shall have no space between laminations. Bus dimensions shall be provided as follows:

Minimum: 1/4 inch by 2 inches

Maximum: 3/4 inch by 2 inches

3. Bus units shall be provided with fixed studs as shown for mounting the current-transformers. Each stud shall consist of a 1/2-inch steel bolt that is secured in place and provided with a spring washer and a nut. The spring washer may be either a split-ring washer installed with a flat washer or conical (Belleville) washer. All parts shall be plated to prevent corrosion.

Note: When conical washers are used, the manufacturer shall provide a readily visible label in the current-transformer compartment clearly identifying the recommended torque setting for the bolt assemblies used with the washers.

4. Except for bus supplying the instrument-transformer compartment, no other conductors or devices shall be installed in, or routed through, the compartment or the sealed area above the compartment.

Exception: Where busway having an integral or internal ground is used to supply the compartment, a ground bus (not cable) shall be permitted to pass through the compartment for connection to the busway grounding provision provided it is located at the side or rear of the compartment and does not infringe on any of the specified bus or working space clearances.

5. A clear unobstructed workspace shall be provided, as shown, around the current-transformer bus units from the horizontal barrier to the bottom of the upper bus support bar.

6. A 10-32 screw and washer (tap) for meter wiring shall be provided on the neutral bus, as shown, or on the neutral cross-bus supplying the compartment or on a bus bar extension provided from the neutral cross-bus. The tap shall be located a minimum of 1-1/2 inches above the horizontal barrier (Note 7) and centered between the phase bus units, or at either side, and shall be readily accessible under energized conditions and with the Department's current-transformers installed.

Note: For 3Ø 3-wire a tap is required on the BØ bus (neutral) unit.

7. The horizontal barrier shall be constructed of a rigid insulating material resistant to ARC tracking and shall be secured in place with a maximum deflection of 1/2 inch from an applied force of 25 pounds downward. Openings in the barrier (i.e., peripheral gaps around barrier, cutouts around bus bars, and holes provided for ventilation) shall not exceed 3/8 inch. The barrier shall be attached with nonconductive fasteners.

8. Dimension measured between the inside edges of the compartment access opening.

9. References:

- a. For instrument-transformer compartment applications, see pages 3-12 and 3-14.
- b. 3Ø 3-wire is not a standard service voltage. For application limitations, see page 1-25.

INSTRUMENT-TRANSFORMER COMPARTMENT FOR SWITCHBOARDS
400-1000 AMPERES, 3Ø 4-WIRE AND 3-WIRE (See Note 11)

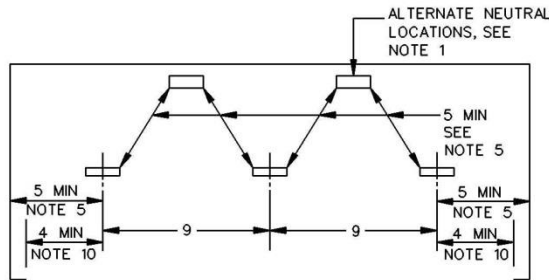

TOP VIEW

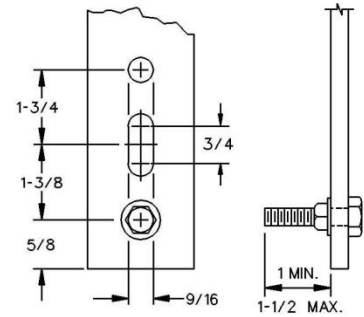

BUS DRILLING DETAIL-TYPICAL 6 LOCATIONS
SEE NOTE 3

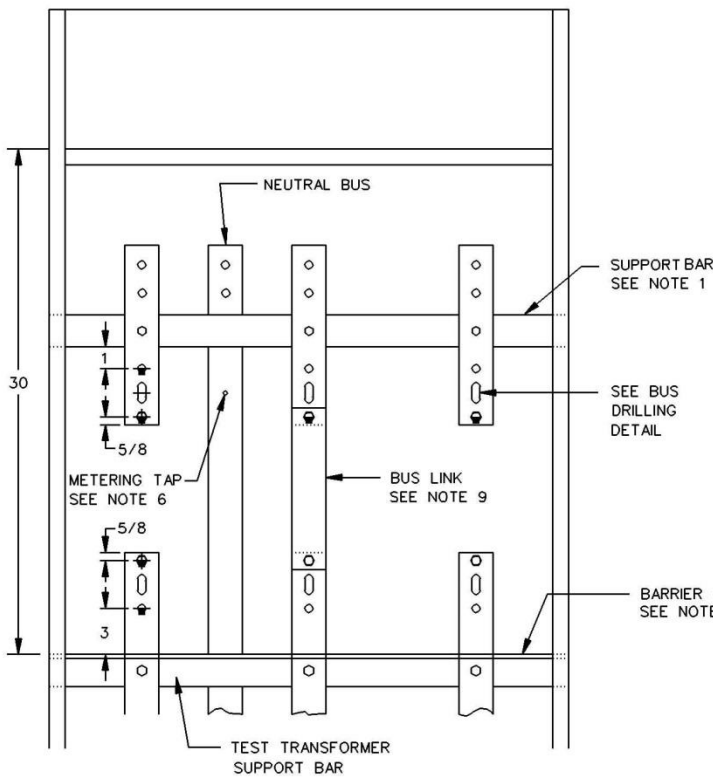

FRONT VIEW

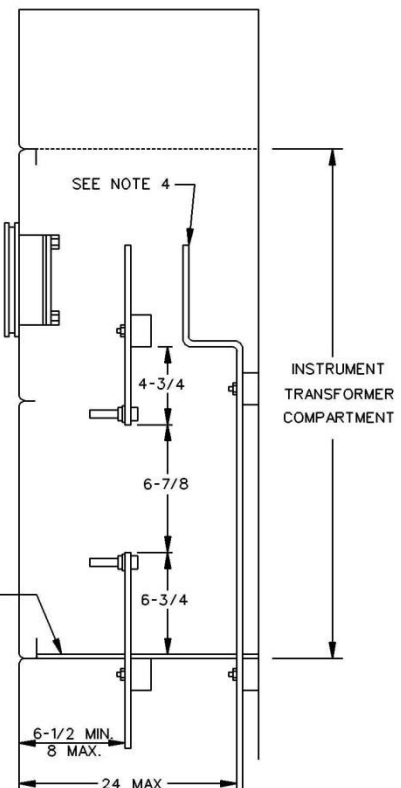

SIDE VIEW

NOTES:

1. Bus arrangements and supports shall be provided as shown, except that the neutral bus may be located on either sidewall or at either side. Bus supports shall be constructed of a continuous bar of non-conducting material and shall be rigid to prevent misalignment of the bus units with the cable in place.

LOW-VOLTAGE SWITCHBOARDS, 0 - 600 VOLTSDate: 05-02-24

INSTRUMENT-TRANSFORMER COMPARTMENT FOR SWITCHBOARDS (Cont.)
400-1000 AMPERES, 3Ø 4-WIRE AND 3-WIRE

2. The current-transformer bus units may be supplied from the top or the bottom and shall be anchored to prevent misalignment. The bus units shall be constructed of rectangular bus and when laminated shall have no space between laminations. Bus dimensions shall be provided as follows:

Minimum: 1/4 inch by 2 inches

Maximum: 3/4 inch by 2 inches

3. Bus units shall be provided with fixed studs as shown for mounting the current-transformers. Each stud shall consist of a 1/2-inch steel bolt that is secured in place and provided with a spring washer and a nut. The spring washer may be either a split-ring washer installed with a flat washer or conical (Belleville) washer. All parts shall be plated to prevent corrosion.

Note: When conical washers are used, the manufacturer shall provide a readily visible label in the current-transformer compartment clearly identifying the recommended torque setting for the bolt assemblies used with the washers.

4. Except for bus supplying the instrument-transformer compartment, no other conductors or devices shall be installed in, or routed through, the compartment or the sealed area above the compartment.

Exception: Where busway having an integral or internal ground is used to supply the compartment, a ground bus (not cable) shall be permitted to pass through the compartment for connection to the busway grounding provision provided it is located at the side or rear of the compartment and does not infringe on any of the specified bus or working space clearances.

5. A clear unobstructed workspace shall be provided, as shown, around the current-transformer bus units from the horizontal barrier to the bottom of the upper bus support bar.
6. A 10-32 screw and washer (tap) for meter wiring shall be provided on the neutral bus unit as shown or on the neutral cross-bus supplying the compartment or on a bus bar extension provided from the neutral cross-bus. The tap shall be located a minimum of 1-1/2 inches above the horizontal barrier (note 7) and centered between the phase bus units, or at either side, and shall be readily accessible under energized conditions and with the Department's current-transformers installed.
7. The horizontal barrier shall be constructed of a rigid insulating material resistant to ARC tracking and shall be secured in place with a maximum deflection of 1/2 inch from an applied force of 25 pounds downward. Openings in the barrier (i.e., peripheral gaps around barrier, cutouts around bus bars, and holes provided for ventilation) shall not exceed 3/8 inch. The barrier shall be attached with nonconductive fasteners.
8. For 120/240 volt 3Ø 4-wire delta services, the power leg (measuring 208 volts-to-ground) bus shall be identified with an orange color, or by tagging or other effective means.
9. For 3Ø 3-wire services, a removable link shall be installed in the center bus unit ("B" phase). The link shall be provided with a 10-32 screw and washer for meter wiring
10. Dimension measured between the inside edges of the compartment access opening.
11. References:
- a. For instrument-transformer compartment applications, see page 3-12 and 3-14.
 - b. 3Ø 3-wire is not a standard service voltage. For application limitations, see page 1-25.

INSTRUMENT-TRANSFORMER COMPARTMENT FOR SWITCHBOARDS
1001-3000 AMPERES, 1Ø 3-WIRE AND 3Ø 3-WIRE (see note 9)

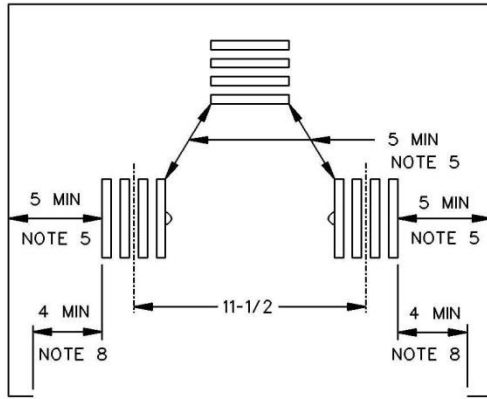

TOP VIEW

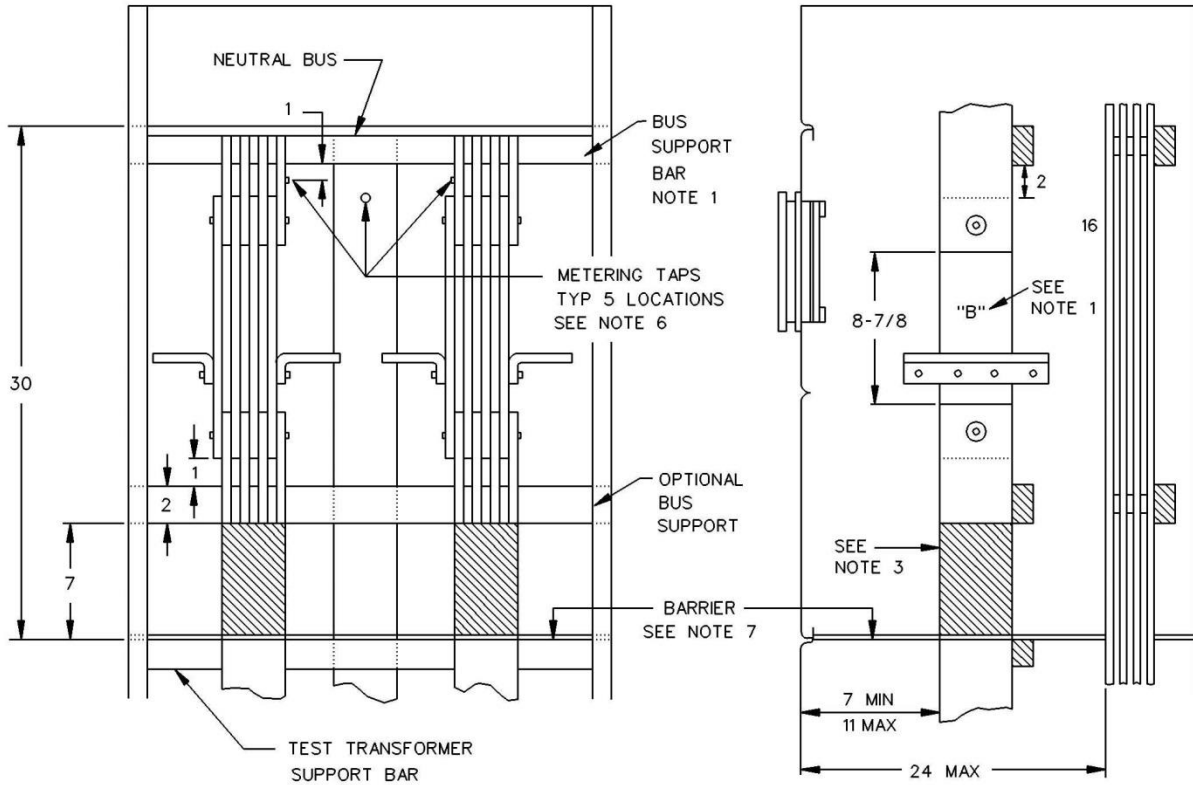

FRONT VIEW

SIDE VIEW

INSTRUMENT-TRANSFORMER COMPARTMENT FOR SWITCHBOARDS (Cont.)
1001-3000 AMPERES, 1Ø 3-WIRE AND 3Ø 3-WIRE**NOTES:**

1. Bus units shall be anchored so that busses will remain in position when the removable bus section ("B") is removed. Bus supports shall be constructed of a continuous bar of non-conducting material.
2. The bus units may be supplied from the top or bottom and shall be constructed of rectangular bus. The maximum allowable bus unit shall not exceed four 1/4 inch by 4 inch bars spaced 1/4 inch.
3. The current-transformer bus units shall be insulated as shown and the insulating material shall be rated for the serving voltage. Bus corners shall be rounded to prevent damage to insulation.
4. Except for bus supplying the instrument-transformer compartment, no other conductors or devices shall be installed in, or routed through, the compartment or the sealed area above the compartment.
Exception: Where busway having an integral or internal ground is used to supply the compartment, a ground bus (not cable) shall be permitted to pass through the compartment for connection to the busway grounding provision provided it is located at the side or rear of the compartment and does not infringe on any of the specified bus or working space clearances.
5. A clear unobstructed workspace shall be provided around the current-transformer bus units from the horizontal barrier to 2 inches above the removable current-transformer bus sections ("B").
6. A 10-32 screw and washer (tap) for meter wiring shall be provided as follows:
 - a. One tap located on each upper phase bus unit for top-feed compartments supplied from the top or on each lower bus unit for compartments supplied from the bottom.
 - b. One tap located on the neutral bus unit shown, or when the compartment is supplied from cross-bussing a tap may be provided from the neutral cross-bus, or on a bus bar extension provided from the neutral cross-bus. Tap locations shall be centered between phase bus units, or at either side, and shall be readily accessible under energized conditions and with the Department's current-transformers installed.
7. The horizontal barrier shall be constructed of a rigid insulating material resistant to ARC tracking and shall be secured in place with a maximum deflection of 1/2 inch from an applied force of 25 pounds downward. Openings in the barrier (i.e., peripheral gaps around barrier, cutouts around bus bars, and holes provided for ventilation) shall not exceed 3/8 inch. The barrier shall be attached with nonconductive fasteners.
8. Dimension measured between the inside edges of the compartment access opening.
9. References:
 - a. For instrument-transformer compartment applications, see pages 3-12 and 3-14.
 - b. For details of the removable bus section and the insulated current-transformer supports, see pages 3-30.
 - c. 3Ø 3-wire is not a standard service voltage. For application limitations, see **SERVICE VOLTAGES** on page 1-25.

INSTRUMENT-TRANSFORMER COMPARTMENT FOR SWITCHBOARDS
1001-3000 AMPERES, 3Ø 4-WIRE AND 3-WIRE (see note 10)

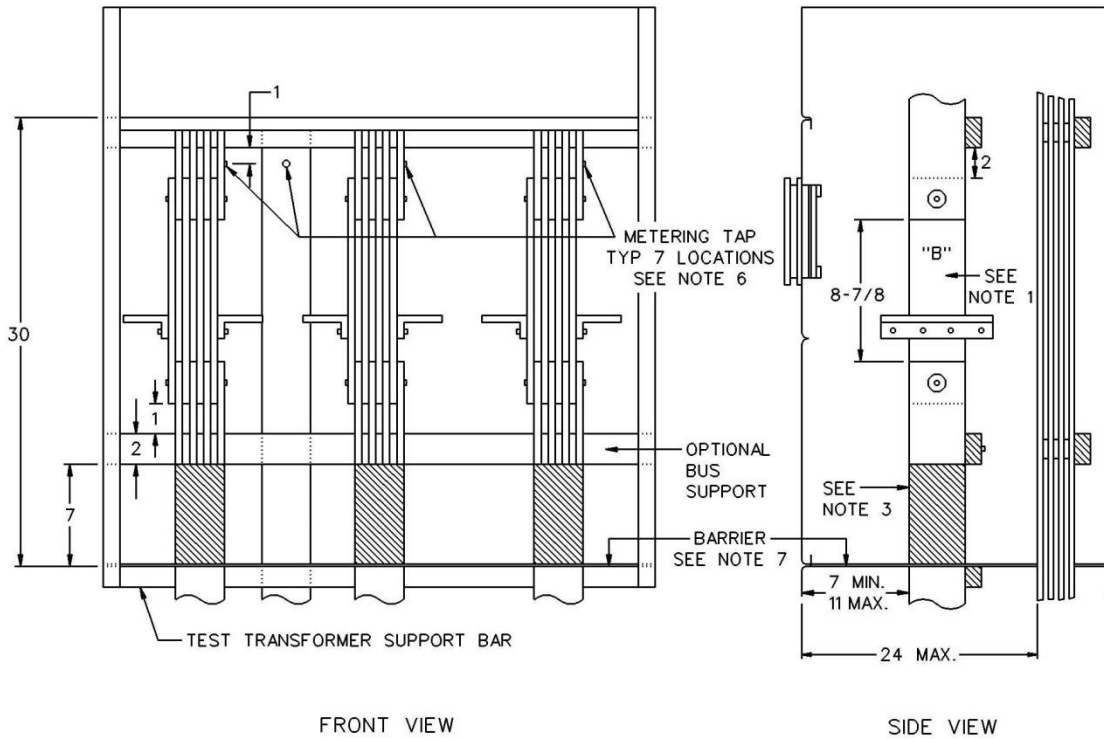
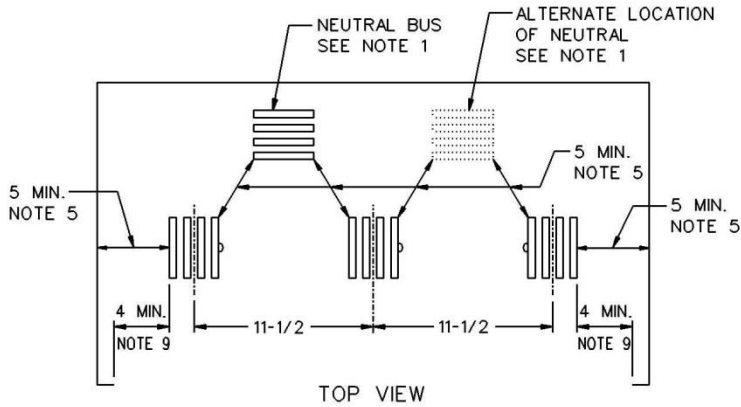

INSTRUMENT-TRANSFORMER COMPARTMENT FOR SWITCHBOARDS (Cont.)
1001-3000 AMPERES, 3Ø 4-WIRE AND 3-WIRE**NOTES:**

1. Bus units shall be anchored so that busses will remain in position when the removable bus section ("B") is removed. Bus supports shall be constructed of a continuous bar of non-conducting material.
2. The bus units may be supplied from the top or bottom, and shall be constructed of rectangular bus. The maximum allowable bus unit shall not exceed four 1/4 inch by 4 inch bars spaced 1/4 inch.
3. Bus units shall be insulated as shown and the insulating material shall be rated for the serving voltage. Bus corners shall be rounded to prevent damage to insulation.
4. Except for bus supplying the instrument-transformer compartment, no other conductors or devices shall be installed in, or routed through, the compartment or the sealed area above the compartment.
Exception: Where busway having an integral or internal ground is used to supply the compartment, a ground bus (not cable) shall be permitted to pass through the compartment for connection to the busway grounding provision provided it is located at the side or rear of the compartment and does not infringe on any of the specified bus or working space clearances.
5. A clear unobstructed workspace shall be provided around the current-transformer bus units from the horizontal barrier to 2 inches above the removable current-transformer bus sections ("B").
6. A 10-32 screw and washer (tap) for meter wiring shall be provided as follows:
 - a. One tap located on each upper phase bus unit for top-feed compartments supplied from the top or on each lower bus unit for compartments supplied from the bottom.
 - b. One tap located on the neutral bus unit shown, or when the compartment is supplied from cross-bussing a tap may be provided from the neutral cross-bus, or on a bus bar extension provided from the neutral cross-bus. Tap locations shall be centered between phase bus units, or at either side, and shall be readily accessible under energized conditions and with the Department's current-transformers installed.
7. The horizontal barrier shall be constructed of a rigid insulating material resistant to ARC tracking and shall be secured in place with a maximum deflection of 1/2 inch from an applied force of 25 pounds downward. Openings in the barrier (i.e., peripheral gaps around barrier, cutouts around bus bars, and holes provided for ventilation) shall not exceed 3/8 inch. The barrier shall be attached with nonconductive fasteners.
8. For 120/240 volt 3Ø 4-wire delta services, the power leg (measuring 208 volts-to-ground) bus shall be identified with an orange color, or by tagging or other effective means.
9. Dimension measured to inside edge of the compartment access opening.
10. References:
 - a. For instrument-transformer compartment applications, see pages 3-12 and 3-14.
 - b. For details of the removable bus section and the insulated current-transformer supports, see pages 3-30.
 - c. 3Ø 3-wire is not a standard service voltage. For application limitations, see **SERVICE VOLTAGES** on page 1-25.

INSTRUMENT-TRANSFORMER COMPARTMENT FOR SWITCHBOARDS
3001 AMPERES AND ABOVE, 3Ø 4-WIRE AND 3-WIRE (see note 9)

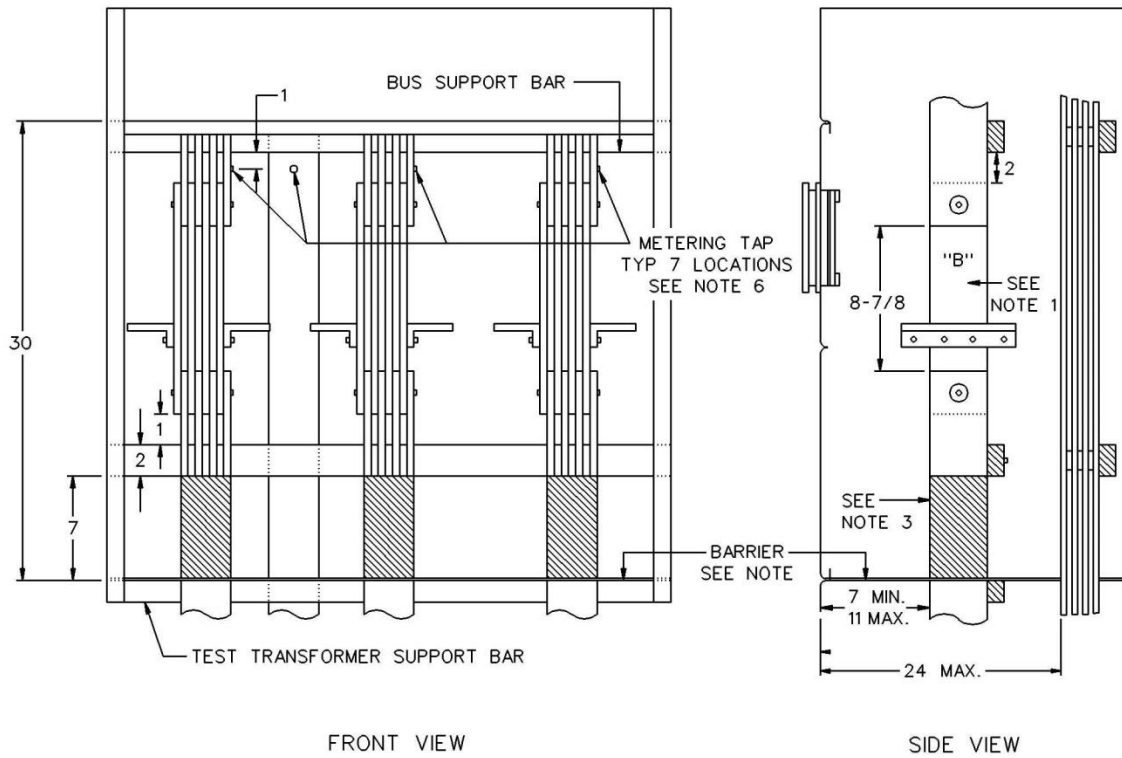
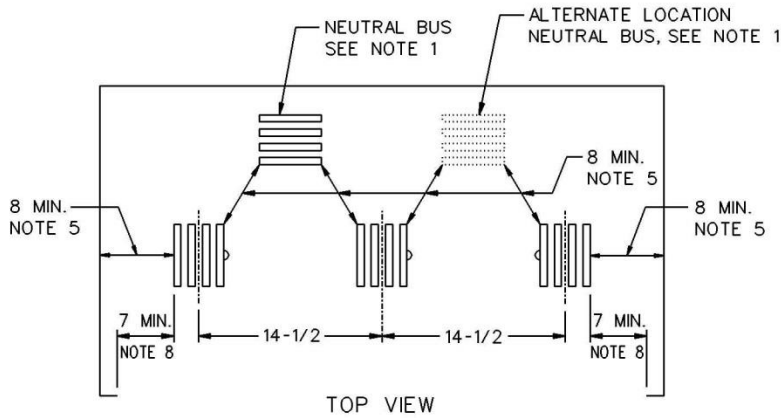

NOTES:

1. Bus units shall be anchored so that busses will remain in position when the removable section ("B") is removed. Bus supports shall be constructed of a continuous bar of non-conducting material.

LOW-VOLTAGE SWITCHBOARDS, 0 - 600 VOLTSDate: 05-02-24

INSTRUMENT-TRANSFORMER COMPARTMENT FOR SWITCHBOARDS (Cont.)
3001 AMPERES AND ABOVE, 3Ø 4-WIRE AND 3-WIRE

2. Current-transformer bus units may be supplied from the top or bottom, and shall be constructed of rectangular bus and shall not exceed the following maximum sizes:

Four 1/4 inch x 4 inch bars spaced 1/4 inch

Six 1/4 inch x 5 inch bars spaced 1/4 inch

Five 3/8 inch x 6 inch bars spaced 3/8 inch

3. Bus units shall be insulated as shown and the insulating material shall be rated for the serving voltage. Bus corners shall be rounded to prevent damage to insulation.

4. Except for bus supplying the instrument-transformer compartment, no other conductors or devices shall be installed in, or routed through, the compartment or the sealed area above the compartment.

Exception: Where busway having an integral or internal ground is used to supply the compartment, a ground bus (not cable) shall be permitted to pass through the compartment for connection to the busway grounding provision provided it is located at the side or rear of the compartment and does not infringe on any of the specified bus or working space clearances.

5. A clear unobstructed workspace shall be provided around the current-transformer bus units from the horizontal barrier to 2 inches above the removable current-transformer bus sections ("B").

6. A 10-32 screw and washer (tap) for meter wiring shall be provided as follows:

- a. One tap located on each upper phase bus unit for top-feed compartments supplied from the top or on each lower bus unit for compartments supplied from the bottom.
- b. One tap located on the neutral bus unit shown, or when the compartment is supplied from cross-bussing a tap may be provided from the neutral cross-bus, or on a bus bar extension provided from the neutral cross-bus. Tap locations shall be centered between phase bus units, or at either side, and shall be readily accessible under energized conditions and with the Department's current-transformers installed.

7. The horizontal barrier shall be constructed of a rigid insulating material resistant to ARC tracking and shall be secured in place with a maximum deflection of 1/2 inch from an applied force of 25 pounds downward. Openings in the barrier (i.e., peripheral gaps around barrier, cutouts around bus bars, and holes provided for ventilation) shall not exceed 3/8 inch. The barrier shall be attached with nonconductive fasteners.

8. Dimension measured to inside edge of the compartment access opening.

9. For 120/240 volt 3Ø 4-wire delta services, the power leg (measuring 208 volts-to-ground) bus shall be identified with an orange color, or by tagging or other effective means.

10. References:

- a. For standard switchboard service sections, see pages 3-12 and 3-14.
- b. For details of the removable bus section and the insulated current-transformer supports, see page 3-30 for 4-inch bus and page 3-32 for 5-inch bus.
- c. 3Ø 3-wire is not a standard service voltage. For application limitations, see **SERVICE VOLTAGES** on page 1-25.

REMOVABLE LINK WITH CURRENT-TRANSFORMER SUPPORT
SINGLE-BOLT MOUNTING PATTERN FOR 4-INCH BUS

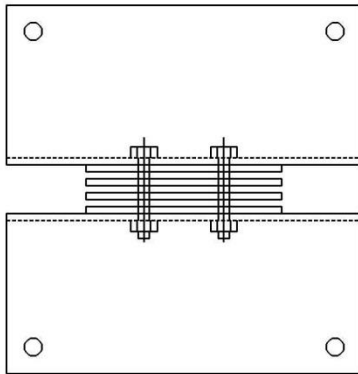

TOP VIEW

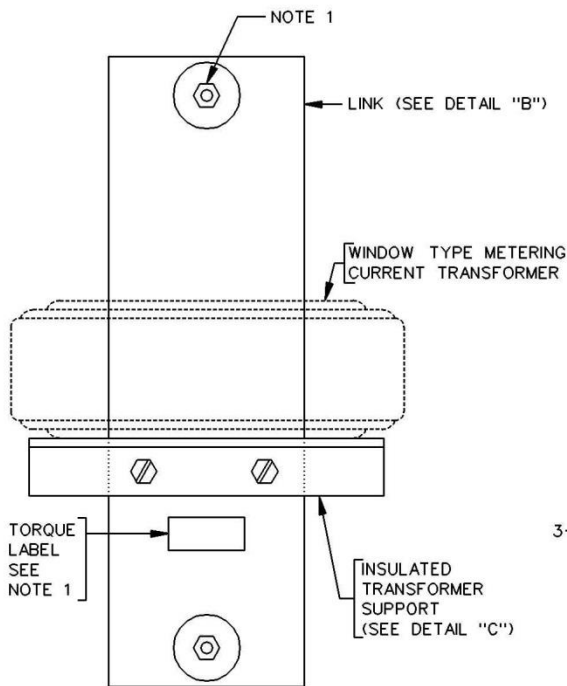

SIDE VIEW

REMOVABLE LINK ASSEMBLY
(FURNISHED BY MANUFACTURER)

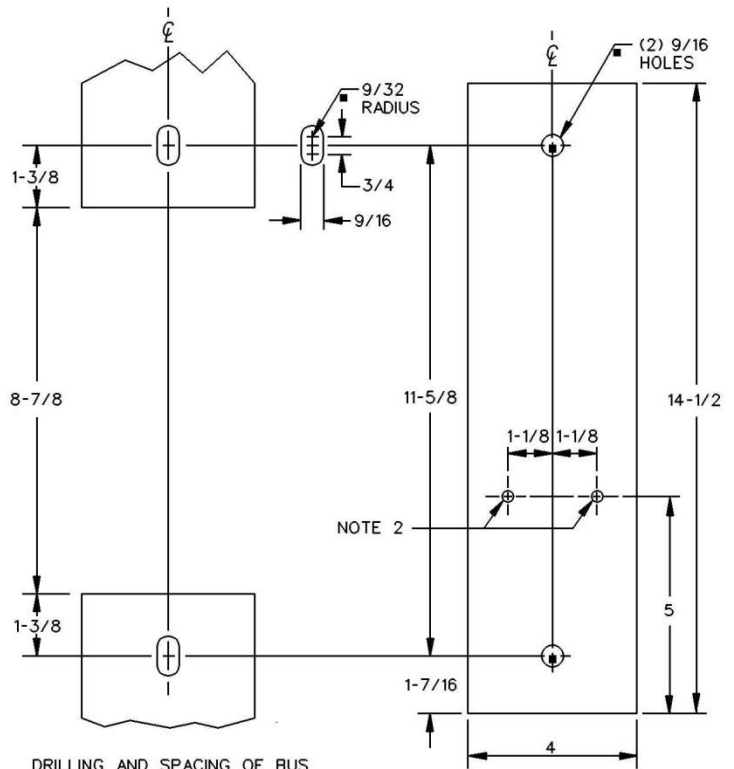

DRILLING AND SPACING OF BUS
DETAIL A

1/4 X 4 REMOVABLE LINK
(SAME MATERIAL AS BUS)
DETAIL B

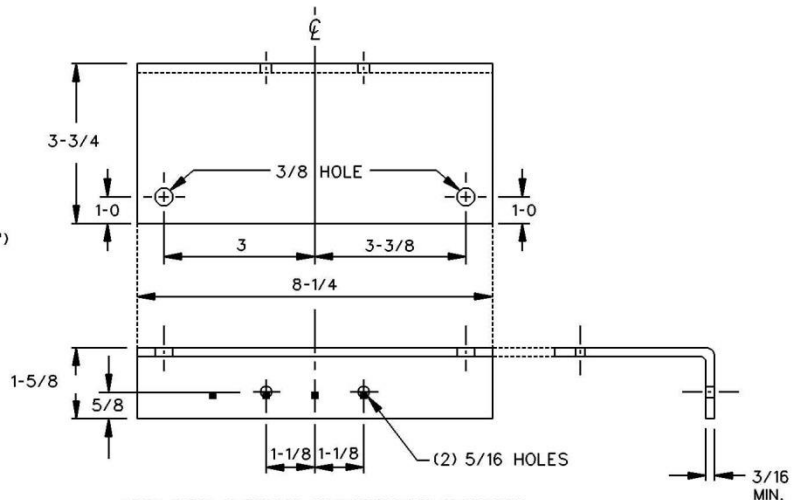

INSULATED CURRENT-TRANSFORMER SUPPORT
(INSULATED, TRACKING RESISTANT MATERIAL)

DETAIL C

REMOVABLE LINK WITH CURRENT-TRANSFORMER SUPPORT (Cont.)**NOTES:**

1. Manufacturer shall secure the removable bus link to the upper and lower current-transformer bus units using 1/2-inch hex-head (grade 5) bolts with spring washers and nuts. Spring washers may consist of either a split-ring washer installed with a 2-1/4-inch minimum diameter flat washer or a 2-1/4-inch minimum diameter conical (Belleville) washer.

Note: When conical washers are used, the manufacturer shall provide a readily visible label in the current-transformer compartment clearly identifying the recommended torque setting for the bolt assemblies used with the washers. The label shall not be installed on removable or hinged access cover panels.

2. Drill and tap two holes as shown on the outer bus units for 1/4-inch x 20 capscrews.
3. References:
 - a. For applications, see pages 3-24, 3-26 and 3-28.

REMOVABLE LINK WITH CURRENT-TRANSFORMER SUPPORT
TWO-BOLT MOUNTING PATTERN FOR 5-INCH BUS

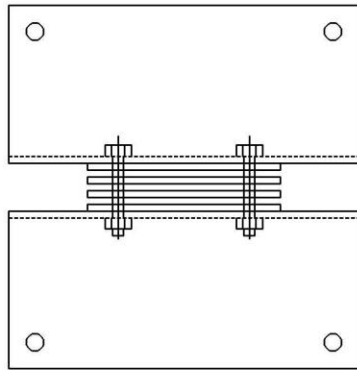

TOP VIEW

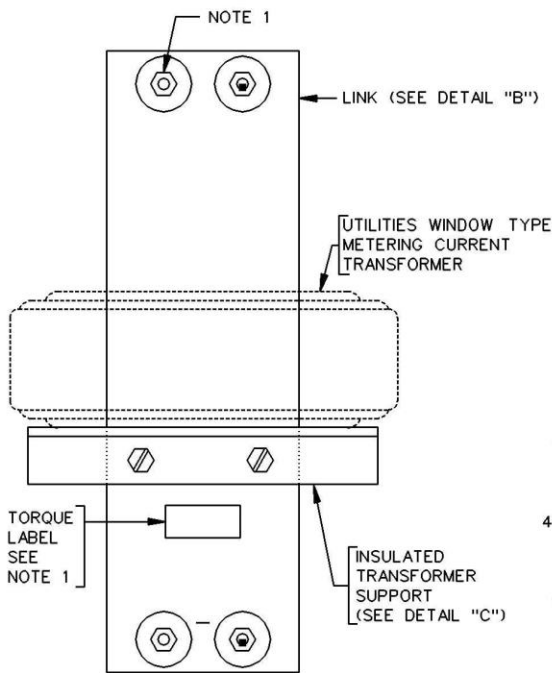

SIDE VIEW

REMOVABLE LINK ASSEMBLY
(FURNISHED BY MANUFACTURER)

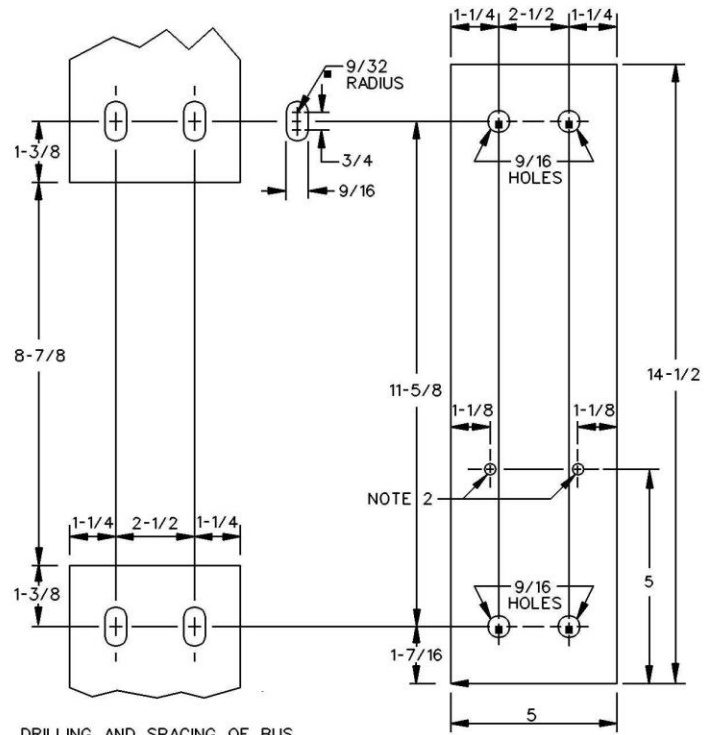

DRILLING AND SPACING OF BUS

DETAIL A

1/4 X 5 REMOVABLE LINK
(SAME MATERIAL AS BUS)

DETAIL B

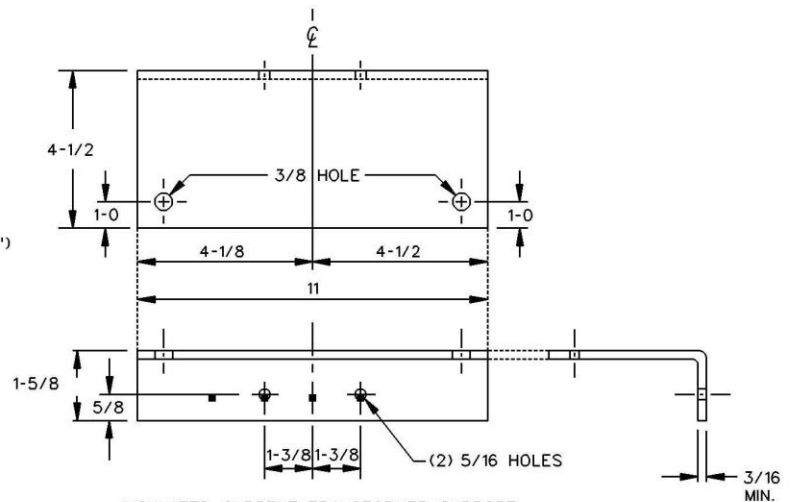

INSULATED CURRENT-TRANSFORMER SUPPORT
(INSULATED, TRACKING RESISTANT MATERIAL)

DETAIL C

REMOVABLE LINK WITH CURRENT-TRANSFORMER SUPPORT (Cont.)**NOTES:**

1. Manufacturers shall secure the removable bus link to the upper and lower current-transformer bus units using 1/2-inch hex-head (grade 5) bolts. Each bolt shall be provided with two 2-1/4 inch minimum diameter conical (Belleville) washers installed on opposite sides of the bus units and a nut.
Note: Manufacturers shall provide a readily visible label in the current-transformer compartment clearly identifying the recommended torque setting for the bolt assemblies used with the washers. The label shall not be installed on removable or hinged access cover panels.
2. Drill and tap two holes as shown on the outer bus units for 1/4-inch x 20 capscrews.
3. References:
 - a. For applications, see page 3-28.

Date: 05-02-24

LOW-VOLTAGE SWITCHBOARDS, 0 - 600 VOLTS

EUSERC DWG. 306

ALL DIMENSIONS SHOWN ARE IN INCHES

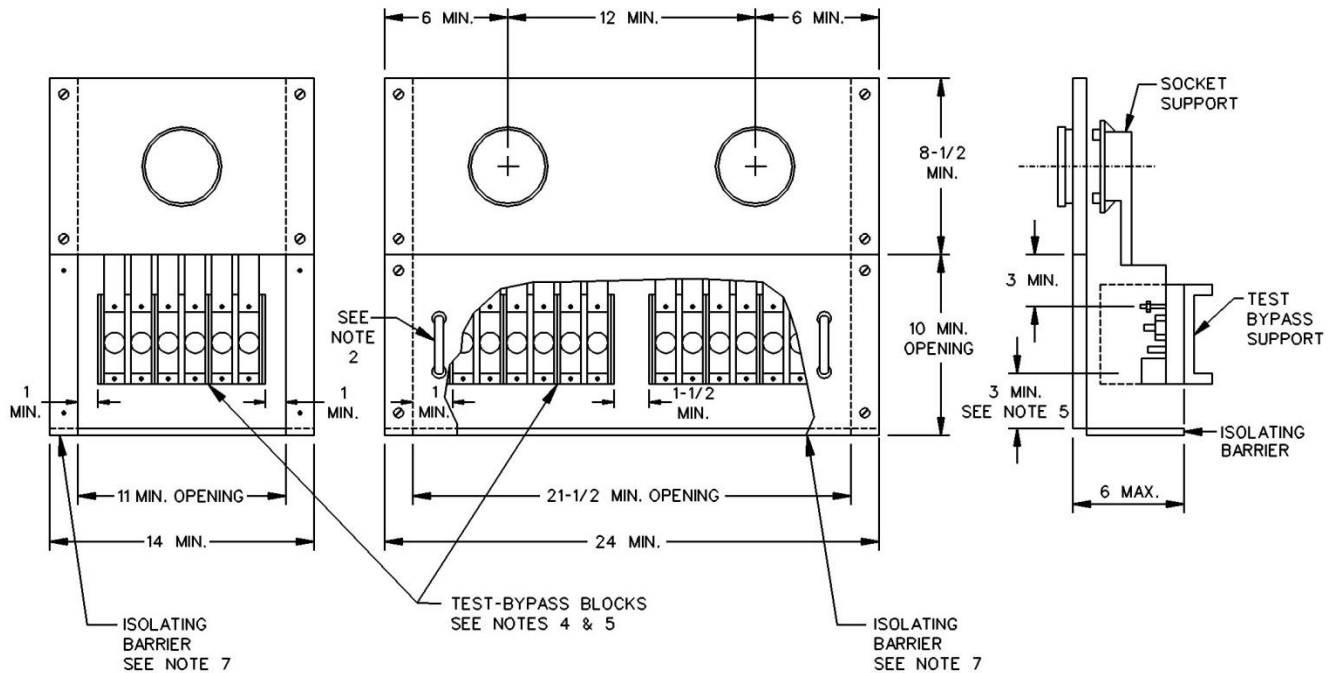
SELF-CONTAINED METERS WITH TEST-BYPASS BLOCKS IN SWITCHBOARDS
200 AMPERES MAXIMUM PER SOCKET

NOTES:

1. Meter panels shall have a maximum of two meter sockets per panel, and shall be not be removable when the meters and sealing rings are in place. The meter sockets shall be supported independent of, and attached to, the meter panel.
2. Test-bypass block compartment cover panels shall have a lifting handle - panels exceeding 16 inches in width require two handles.
3. All panels shall be sealable.
4. Test-bypass blocks with rigid insulating barriers shall be furnished, installed, and wired or bussed to the meter socket by the manufacturer and provided as follows:
 - a. For 1 \emptyset , 3-wire, provide two test-bypass blocks mounted in the outer positions and a 4-jaw socket. For 120/208 volts, 1 \emptyset 3-wire, provide two test-bypass blocks mounted in the outer positions and a 5-jaw meter socket - connect the 5th jaw of the meter socket to the insulated neutral terminal (see note 6) with a white No. 12 AWG (minimum) copper wire.
 - b. For 3 \emptyset , 3-wire, provide three test-bypass blocks and a 5-jaw meter socket - connect the line and load poles together at top of center position test-bypass block with a bus section and connect the bus to the 5th jaw of the meter socket with a No. 12 AWG (minimum) copper wire. Color used to identify the wire shall not be white, gray, green, or orange.

LOW-VOLTAGE SWITCHBOARDS, 0 - 600 VOLTS

Date: 01-01-10

SELF-CONTAINED METERS WITH TEST-BYPASS BLOCKS IN SWITCHBOARDS (Cont.)

- c. For 3 \emptyset , 4-wire, provide three test-bypass blocks and a 7-jaw meter socket - connect the 7th jaw of the meter socket to the insulated neutral terminal (see note 6) with a white No. 12 AWG (minimum) copper wire. For 120/240 volts, 4-wire delta, the right hand test-bypass block shall be the power leg (measures 208 volts-to-ground) and shall be identified with an orange color.
 - d. Test-bypass block connection sequence shall be LINE-LOAD from left to right and shall be clearly identified in 3/4-inch minimum block letters.
5. Test-bypass blocks shall be installed with the following clearances:
 - a. 3-inches of vertical clearance from the upper test connector stud to the upper compartment access opening.
 - b. 3-inches from the center of the cable terminal screw (or lower test connector stud if there is no cable terminal) to the lower compartment access opening. Field installed conductors may require a greater dimension.
 - c. 1-inch of side clearance from the outer rigid insulating barriers to the compartment access openings.
 6. An insulated neutral terminal shall be provided behind each test-bypass cover panel for 1 \emptyset 3-wire and 3 \emptyset 4-wire meter sockets. The terminal shall be readily accessible when the cover panel is removed and shall be individually connected to the neutral bus with a minimum size No. 8 AWG copper wire.
 7. A factory-installed, full-width insulating barrier shall be located at the bottom of each test-bypass compartment. In addition, a full width and depth isolating barrier shall be located below the bottom test-bypass compartments and above the meter disconnect devices. If a factory-installed rear load wireway is provided, the isolating barrier shall extend back to that wireway. Ventilation openings, when provided, shall not exceed a maximum diameter of 3/8 inch. A slot in the isolating barrier provided for the load conductors supplied from the test-bypass blocks shall be a maximum of 3-inches in depth and may extend to the width of the meter disconnect devices. The slot may not be located in the front 6 inches of the test-bypass compartment insulating barrier.
 8. Metered conductors shall not pass through adjacent metering compartments except in enclosed wireways. To insure proper identification of cables in factory cabled equipment, metered cables (except in the test-bypass area) shall be either physically barriered or bundled so as to separate them from unmetered cable or permanently marked and isolated from unmetered cables. Physical barriers will not be required if unmetered conductors are bus.
 9. Separate line and load conductors shall be installed and connected by the contractor or manufacturer for each test-bypass block position.
 10. Meter disconnect devices shall not be installed in front of horizontal cross bussing.
 11. References:
 - a. For meter socket jaw arrangements, see page 2-5.
 - b. For sealing requirements, see page 3-10.
 - c. For lifting handle requirements, see page 3-10.
 - d. For test-bypass block requirements, see page 2-30.

Date: 05-02-24

LOW-VOLTAGE SWITCHBOARDS, 0 - 600 VOLTS

EUSERC DWG. 353

ALL DIMENSIONS SHOWN ARE IN INCHES

REQUIRED CLEARANCES FOR TYPICAL RESIDENTIAL MULTIPLE-METERING ARRANGEMENTS

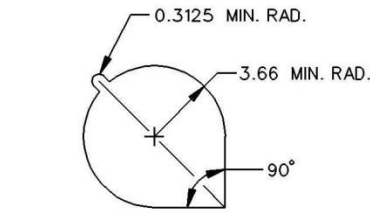

METER CUTOUT DETAIL
FIG. 1

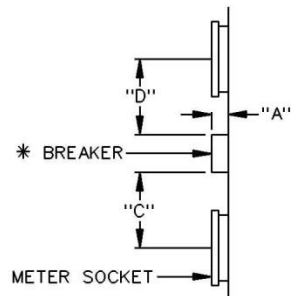

SIDE VIEW DETAIL
FIG. 2

* Alternate breaker position below meter socket. See side view detail for clearance dimensions.

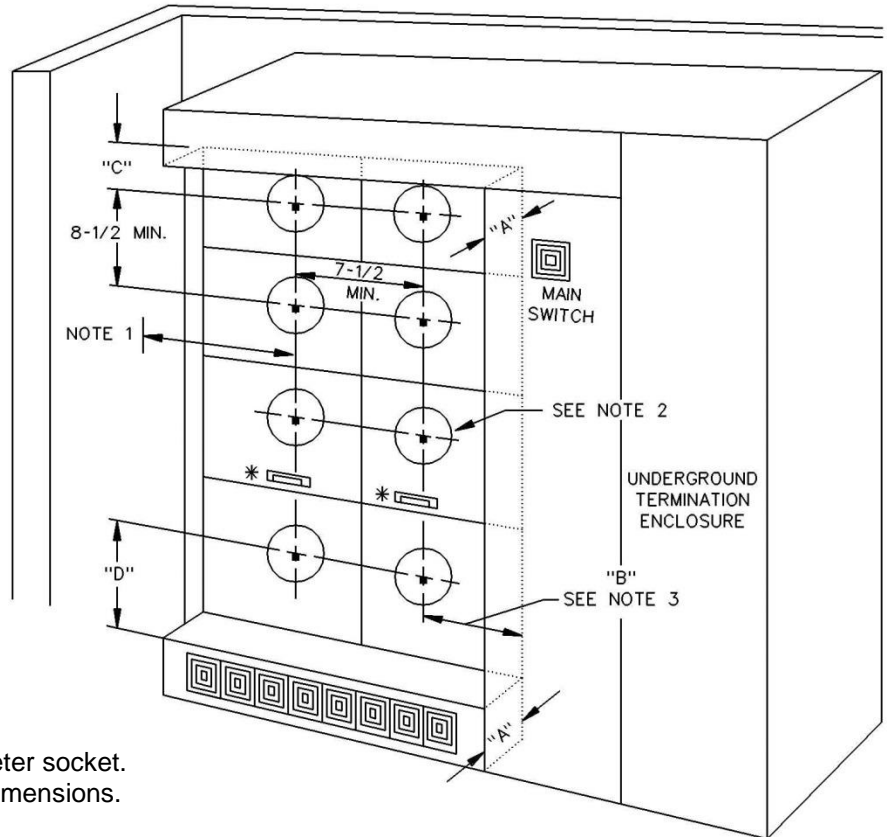

TABLE 1

"A" (Protrusion)	Minimum Dimensions		
	"B"	"C"	"D"
0"	3-3/4"	4"	4-3/4"
Greater than 0" to 1-1/8" max	4-1/4"	4"	4-3/4"
Greater than 1-1/8" to 2" max	4-1/4"	4-1/4"	6-1/4"
Greater than 2" to 4" max	6-1/4"	4-1/4"	8"
Greater than 4" to 11" max.	6-1/4"	10"	8"

NOTES:

1. Where an adjacent wall or other obstruction extends more than 11 inches perpendicular from the face of the meter panel, a minimum side clearance of 10 inches shall be provided from the wall or obstruction to the center of the meter socket(s). For obstructions extending less than 11 inches from the meter panel, the required minimum clearances are specified in Table 1.
2. Panels shall be removable to provide access to the customer's equipment with Department's meters and security sealing or locking rings in place. When more than one meter socket is provided on a single panel, a cutout shall be provided for the meter as shown in Figure 1.

REQUIRED CLEARANCES FOR TYPICAL RESIDENTIAL MULTIPLE-METERING ARRANGEMENTS (Cont.)

3. Dimension "B" shall be increased by the amount that the service main disconnect door (including the operating handle) reduces the clearance when opened 90-degrees. For Protrusions not more than 2 inches in height and which are related specifically to compartment components such as an individual breaker cover, sealing provisions, venting, etc., the minimum "B" clearance can be reduced to 3-3/4 inches.
4. Removable meter panel cover dimensions shall not exceed 6 square feet in area or 5 feet in length or width.
5. Metered conductors shall be either physically barriered, so as to separate them from unmetered conductors, or permanently marked and isolated from unmetered conductors. Physical barriers may not be required if one set of conductors are solid bus and the other set are either bus or cable.
6. References:
 - a. For meter socket jaw arrangements, see page 2-5.
 - b. For meter height and clearance requirements, see page 5-12.

Date: 05-02-24

LOW-VOLTAGE SWITCHBOARDS, 0 - 600 VOLTS

EUSERC DWG. 354

ALL DIMENSIONS SHOWN ARE IN INCHES

OUTDOOR OR RAIN TIGHT ENCLOSURES FOR SWITCHBOARDS

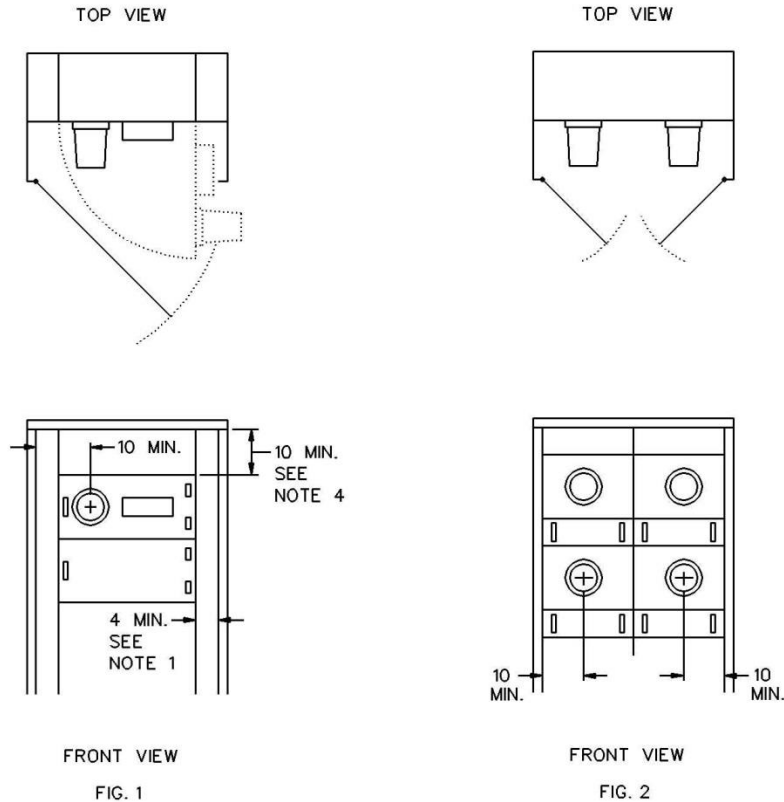
**NOTES:**

1. Hinged meter panels shall be capable of being opened 90-degrees or more with the meter and test switch installed. The following clearances shall be provided from the meter panel to any obstruction:
 - a. 11 inches at the meter socket.
 - b. 4 inches at the test switch slot.
2. Enclosure doors providing access to utility compartments (i.e., metering sections and pull sections) shall be:
 - a. Equipped with durable devices to hold the doors in the open position at 90-degrees or more. The devices shall be permanently attached to either the enclosure or the doors and may be either automatic or manual but shall not require disassembly to operate.
 - b. Secured in the closed position with a full hand grasping, single handle-operated latching system. When provided with a locking means, each door or set of doors, shall be equipped with an approved double locking device, accepting a 5/16-inch lock shaft, to allow access by both the Department and the customer.
3. A level standing and working space shall extend from the face of the enclosure to any property line or obstruction. When in the open position, the doors shall provide a minimum 24-inch access/exit route.

OUTDOOR OR RAIN-TIGHT ENCLOSURES FOR SWITCHBOARDS (Cont.)

4. Dimension may be reduced if the service section is supplied from cross bussing or bus duct.
5. When the meter cabinet is to be locked, the customer shall install either a double locking mechanism or a lock-box. The lock box shall be in a permanent location on the meter cabinet door, on the meter cabinet, or in a readily accessible location adjacent to the meter cabinet. The Department will supply the lock-box.
Note: For lock-box installations, the customer shall provide a key for the meter cabinet door lock to be housed in the lock-box before the electric service will be energized. The key will be used for access by the Department.
6. References:
 - a. For standard switchboard service sections, see pages 3-12 and 3-14.
 - b. For meter panels, see pages 3-4, 3-16, 3-18, 3-34 and 3-36.
 - c. For sealing requirements, see page 3-10.
 - d. For meter height requirements, see page 5-13.

TYPICAL SWITCHBOARD TERMINATION ARRANGEMENTS FOR OVERHEAD SUPPLY

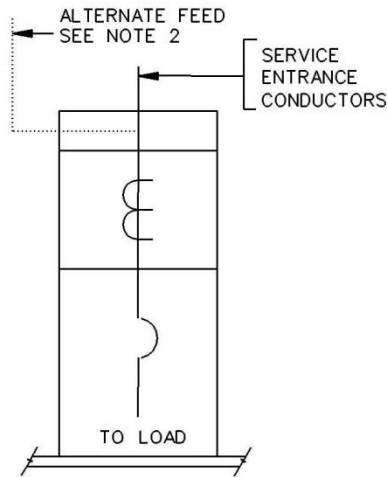

SERVICE SECTION WITH CABLE SUPPLY

FIGURE 1

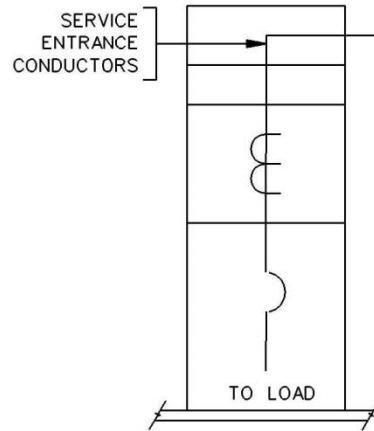

SERVICE SECTION WITH EXTENSION AND CABLE SUPPLY

FIGURE 2

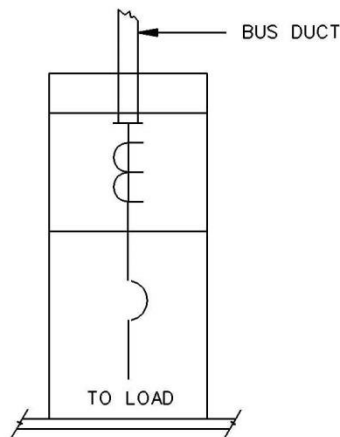

SERVICE SECTION WITH BUS DUCT SUPPLY

FIGURE 3

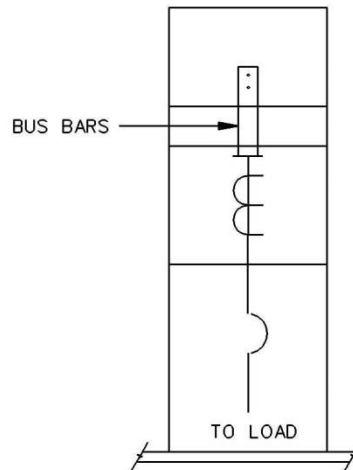

SERVICE SECTION WITH BUSSED EXTENSION

FIGURE 4

NOTES:

1. Service entrance conductors shall be furnished and installed by the customer from the service head to the switchboard service section.

TYPICAL SWITCHBOARD TERMINATION ARRANGEMENTS FOR OVERHEAD SUPPLY (Cont.)

2. Cable conductors should enter through the top (preferred point of entry) of the switchboard service section (figure 1), or through the side or back of a top hat installed above the service section (figure 2) and terminate at the top of the current-transformer bus units. If this is not practical, the conduits may, with Department approval, enter through the side or back (See "alternate feed" in figure 1) in the sealable section above the instrument-transformer compartment - for this type of entry, the top of the conduit shall not be more than three inches from the top of the switchboard service section and the cables shall be installed to prevent turning or misalignment of the current-transformer bus units.

Note: The cables shall not terminate on cross bussing or in any location behind or to the side of the current-transformer mounting area (below the upper bus support bar).

Caution: The number of service entrance conductors permitted is limited at the weatherhead. See **SERVICE ENTRANCE CONDUCTORS**, page 7-14.

3. Bus duct (figure 3) may enter either through the top of the switchboard service section, or at the side or back in the sealable section above the instrument-transformer compartment.
4. A bussed top hat extension (figure 4) with cable terminating facilities is required when the Department installs and terminates the conductors at the switchboard (i.e., typical of Indoor Customer Station installations). Consult the Department regarding extension requirements.
5. Additional references:
- a. For switchboard service section requirements, see pages 3-12 and 3-14.
 - b. For sealing requirements, see page 3-10.
 - c. For lifting handle requirements, see page 3-10.
 - d. For service drop and clearance requirements, see page 7-4.
 - e. For busway service head requirements, see pages 3-48.
 - f. For service drop attachment requirements, see page 7-9.
 - g. For service head requirements, see page 7-14.

TYPICAL SWITCHBOARD TERMINATION ARRANGEMENTS FOR UNDERGROUND SUPPLY

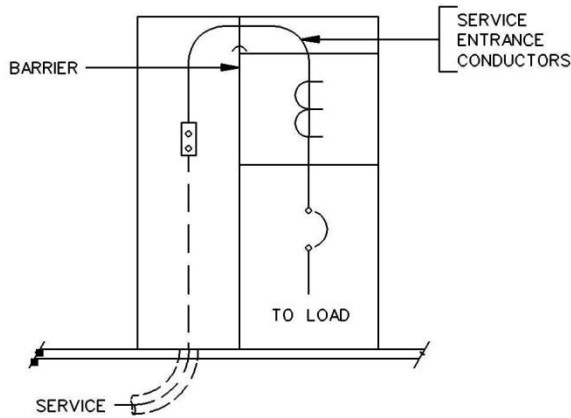

SERVICE SECTION WITH PULL SECTION
800 AMPERES MAXIMUM
SEE NOTES 2,3,4 AND 5

FIGURE 1

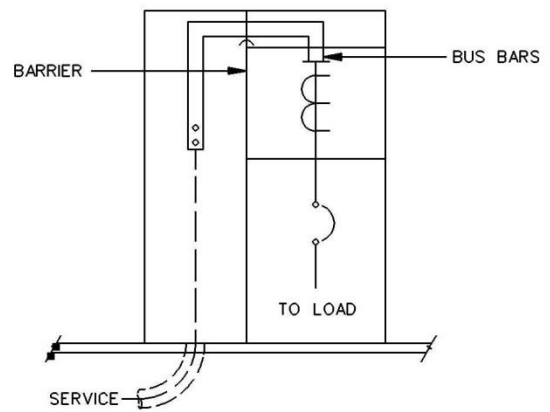

SERVICE SECTION WITH PULL SECTION
OVER 800 AMPERES
SEE NOTES 2,3 AND 5

FIGURE 2

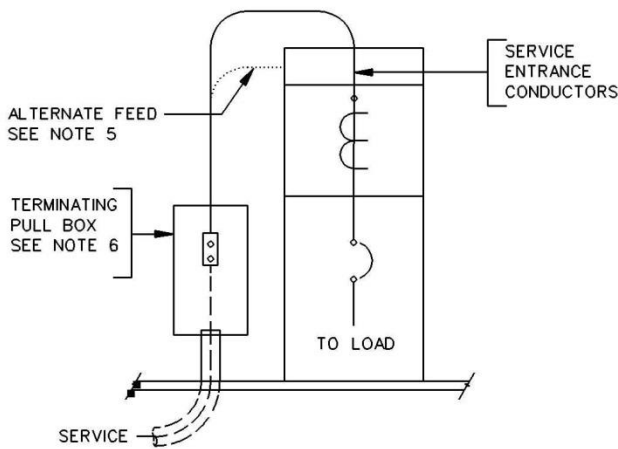

SERVICE SECTION WITH SEPARATE PULL BOX
800 AMPERES MAXIMUM

FIGURE 3

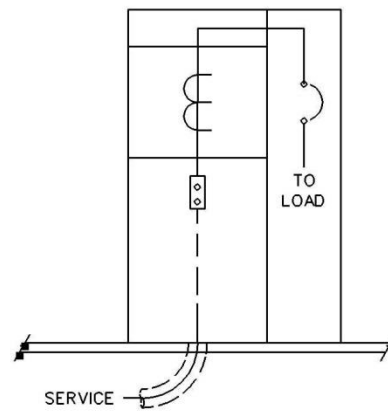

BOTTOM-FEED SERVICE SECTION
2000 AMPERES MAXIMUM
SEE NOTES 3 AND 7
FIGURE 4

NOTES:

1. A switchboard pull section (figures 1 and 2), a separate pull box (figure 3), or a bottom-feed service section (figure 4) shall be provided for underground service.

Note: The bottom-feed section may be either a metering section serving a single-customer or a main service disconnect supplying multiple-metering sections.

TYPICAL SWITCHBOARD TERMINATION ARRANGEMENTS FOR UNDERGROUND SUPPLY (Cont.)

2. Terminating facilities for the Department's service supply conductors shall be provided in all pull sections.
3. The Department's service supply conduits shall be plum, level, square and reasonably centered on terminating facilities.
4. Either bus bars or cables may extend from the pull section terminating facilities into the switchboard service section of switchboards rated up to 800 amperes. Bus bars are required from the pull section into the switchboard service section of switchboards rated above 800 amperes.
5. When the service section is supplied from a pull section, the bus or cable shall enter the side or back of the sealable section above the instrument-transformer compartment as shown in figures 1 and 2. When the service section is supplied by horizontal cross bussing, the bussing may enter the instrument-transformer compartment in the area behind the current-transformer bus and above the compartment horizontal barrier.
6. When the service section is supplied from a separate pull box as shown in figure 3, the conductors shall enter either the top (preferred point of entry) of the switchboard service section or through the side or back of a top hat installed above the switchboard service section. If this is not practical, the conduits may, with Department approval, enter through the side or back (alternate feed) in the sealable section above the instrument-transformer compartment - for this type of entry, the top of the conduit shall not be more than 3 inches from the top of the switchboard service section and the customer shall install the conductors to prevent turning or misalignment of the current-transformer bus units.
Note: The cables shall not terminate on cross bussing or in any location behind or to the side of the current transformer mounting area (below the upper bus support bar).
7. When the service section is supplied from a bottom-feed compartment as shown in figure 4, either bus bars or cables may extend from the service section into the service disconnect section of switchboards rated up to 800 amperes. Bus bars are required from the service section into the service disconnect section of switchboards rated above 800 amperes.
8. References
 - a. For standard switchboard service (metering) section requirements, see pages 3-12 and 3-14.
 - b. For bottom-feed switchboard service sections, see page 3-44.
 - c. For standard pull section requirements, see page 3-44.
 - d. For non-standard pull section requirements, see page 3-46.
 - e. For pull box requirements, see pages 2-13 and 2-14.

Date: 01-01-07

LOW-VOLTAGE SWITCHBOARDS, 0 - 600 VOLTS

EUSERC DWG. 327 AND 345

ALL DIMENSIONS SHOWN ARE IN INCHES

STANDARD TERMINATING PULL SECTIONS, BOTTOM-ENTRY

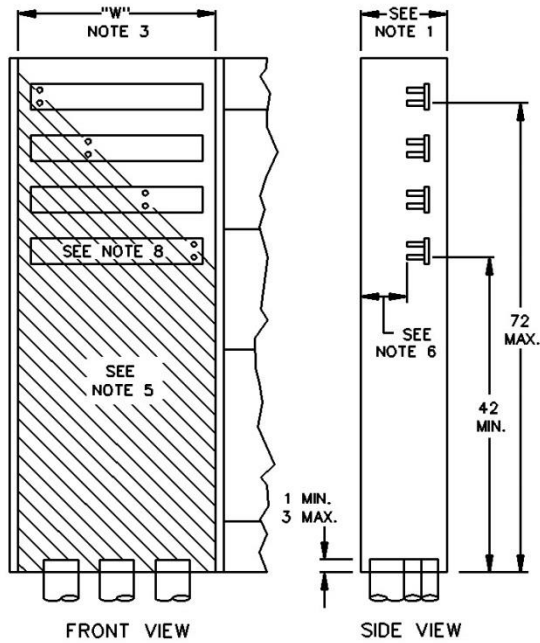

PULL SECTION
FIGURE 1

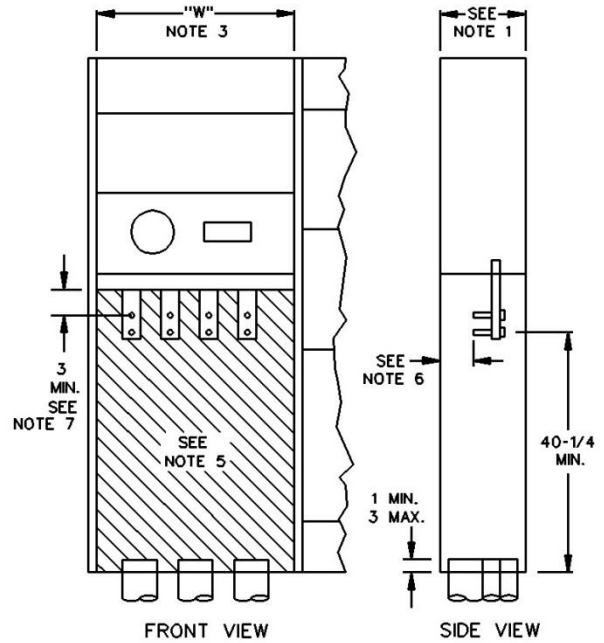

COMBINATION PULL SECTION
AND METERING COMPARTMENT
2000 AMPERES MAXIMUM

FIGURE 2

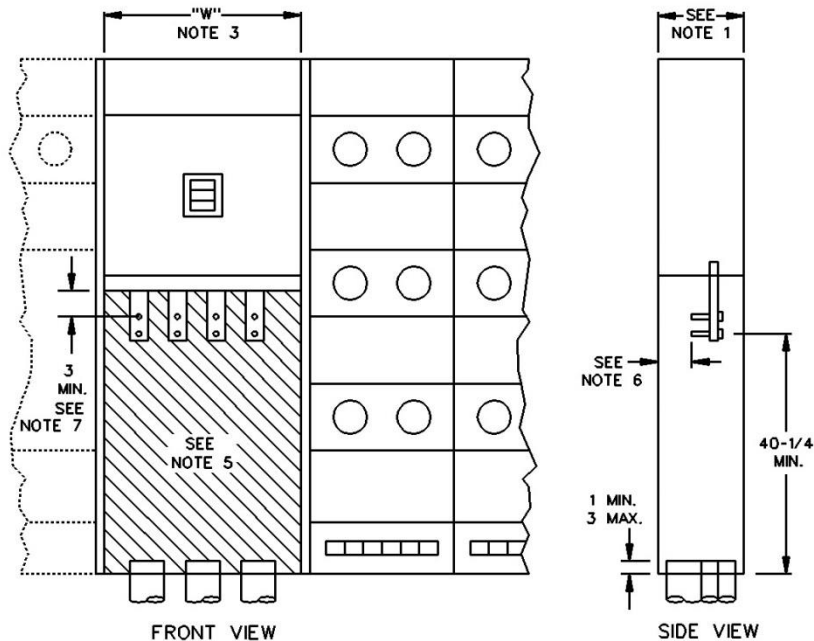

COMBINATION PULL SECTION AND MAIN SERVICE
DISCONNECT FOR MULTI-METER SERVICE
2000 AMPERES MAXIMUM

FIGURE 3

STANDARD TERMINATING PULL SECTIONS, BOTTOM-ENTRY (Cont.)

SWITCHBOARD RATING (AMPERES)	MINIMUM ACCESS OPENING DIMENSION (W) - SEE NOTE 3	
	3-WIRE	4-WIRE
0 - 400	18"	24"
401 - 800	24"	24"
801 - 1200	24"	30"
1201 - 2000	30"	35"
2001 - 3000	35"	42"
3001 - 5000	42"	44"

NOTES:

1. There is no minimum depth dimension specified for the pull section enclosure except that which is required to provide adequate space for conduit entry and maintain the bus and termination clearances. For pull sections exceeding 2999 amperes, the maximum outside depth of the enclosure shall be limited to no more than 54".
2. Pull section access cover panels shall be independent of other service equipment and removable without disturbing adjacent panels; sealable, provided with lifting handles, and limited to 9 square feet in area with a maximum width or length of 5 feet. Brackets or braces, either permanent or removable, used to support or Provide for weatherproofing of the removable access cover panels are not permitted.
3. The minimum access opening dimension ("W") is measured between the inside edges of the left and right side return flanges.
Note: The actual enclosure outside dimension will be larger and will vary between manufacturers.
4. Terminating facilities shall be provided for termination of the Department's service supply conductors.
Note: Terminating facilities shall be supported to prevent misalignment of the current-transformer bus units with the utility cables installed.
5. The shaded area is reserved for the Department's service supply conductors. No conduits or customer wiring shall terminate in, or be routed through, this area including ground connections. No customer-owned devices (i.e., fuses, cable limiters, surge arrestors, current-transformers and other customer-owned devices) shall be installed anywhere in this section.
6. The minimum clearance from any energized part to a removable access cover panel shall be 4 inches. This dimension may be reduced to 1-1/2 inches if a removable safety barrier is provided by the manufacturer.
7. 3 inch dimension measured from the centerline of the top terminating bolt to any obstruction including the exterior cover panel.
8. Cross-bussing of a different phase or potential installed behind or below any terminating position shall be fully insulated or barriered. Insulating barriers shall be a rigid, nonflammable material rated for the serving voltage, resistant to ARC tracking, resistant to puncture or damage by impact, and attached with non-conducting fasteners.
9. Additional references:
 - a. For typical installation arrangements, see page 3-42.
 - b. For sealing requirements, see page 3-10.
 - c. For lifting handle requirements, see page 3-10.
 - d. For bonding and ground requirements, see page 3-10.
 - e. For cable termination facilities, see page 2-12.

**NONSTANDARD TERMINATING PULL SECTIONS
FOR BELOW GROUND LEVEL INSTALLATIONS (SEE NOTE 1)**

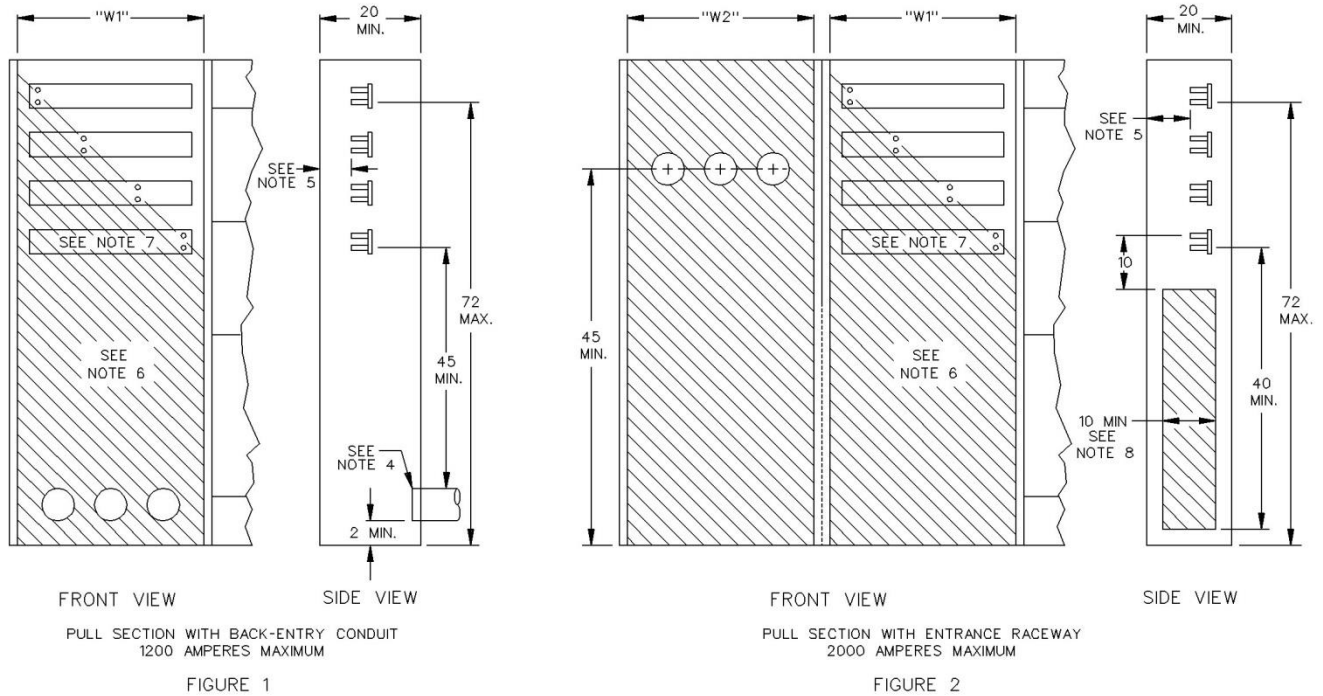

SWITCHBOARD RATING (AMPERES)	MINIMUM ACCESS OPENING DIMENSION - SEE NOTE 3		
	PULL SECTION (W1)		ENTRANCE WIREWAY (W2)
	3-WIRE	4-WIRE	
0 - 400	18	24	18
401 - 800	24	24	
801 - 1200	24	30	24
1201 - 2000	30	35	

NOTES:

1. For the purpose of these requirements, "nonstandard" means that the equipment arrangements represented above are not standard construction and require special ordering from manufacturers.
2. The pull section and entrance wireway access cover panels shall be independent of other service equipment and removable without disturbing adjacent panels; sealable, provided with lifting handles, and limited to 9 square feet in area with a maximum width or length of 5 feet. Brackets or braces, either permanent or removable, used to support or provide for weatherproofing of the removable access cover panels are not permitted.
3. The minimum access opening dimensions ("W1" and "W2") are measured between the inside edges of the left and right side return flanges.

NONSTANDARD TERMINATING PULL SECTIONS (Cont.)

4. For Figure 1 applications the customer must provide the dimension measured from the bottom of the pull section to the top of the highest supply conduit when ordering the pull section to assure proper termination height.
5. The terminating facilities shall be located as far forward (close to the pull section access cover panels) as possible to provide for adequate cable bending radius.
Note: The minimum clearance from any energized part to a removable access cover panel shall be 4 inches. This dimension may be reduced to 1-1/2 inches if a removable safety barrier is provided by the manufacturer.
6. The shaded area is reserved for the Department's service supply conductors. No conduits or customer wiring shall be installed in or routed through this area. No other conductors or ground connections shall be routed through or terminated in this area. No customer-owned devices (i.e., fuses, cable limiters, surge arrestors, current-transformers and other customer-owned devices) shall be installed anywhere in this section.
7. Cross-bussing of a different phase or potential installed behind or below any terminating position shall be fully insulated or barriered. Insulating barriers shall be a rigid, nonflammable material rated for the serving voltage, resistant to ARC tracking, resistant to puncture or damage by impact, and attached with non-conducting fasteners.
8. The edges of the cable window between the entrance raceway and the pull section shall be rounded or otherwise protected to prevent damage to the service supply conductors.
Note: The width of the cable window shall provide direct access to each specified cable terminating position without bending around the window edges.
9. Conduits shall not enter the side of any pull section without the express permission of the Department. Side entry conduits may require a wide pull section enclosure to assure adequate spacing for cable bending radius.
10. Nonstandard terminating pull sections **shall not** be installed in conjunction with on-site transformer pad mount and vault substructures.
Note: When it is necessary to locate the service below grade level and it is fed by either a substructure or a pole, a double terminated pull section shall be required at grade level to prevent water intrusion into the electrical room. A means of service disconnect shall not be allowed with this pull section unless it is also located adjacent to its related meter socket(s). Consult the Department for specific requirements.
11. References:
 - a. For typical installation arrangements, see page 3-42.
 - b. For sealing requirements, see page 3-10.
 - c. For lifting handle requirements, see page 3-10.
 - d. For cable termination facilities requirements, see page 2-12.

BUSWAY SERVICE HEADS
1Ø 3-WIRE AND 3Ø 4-WIRE and 3-WIRE (See Note 8)

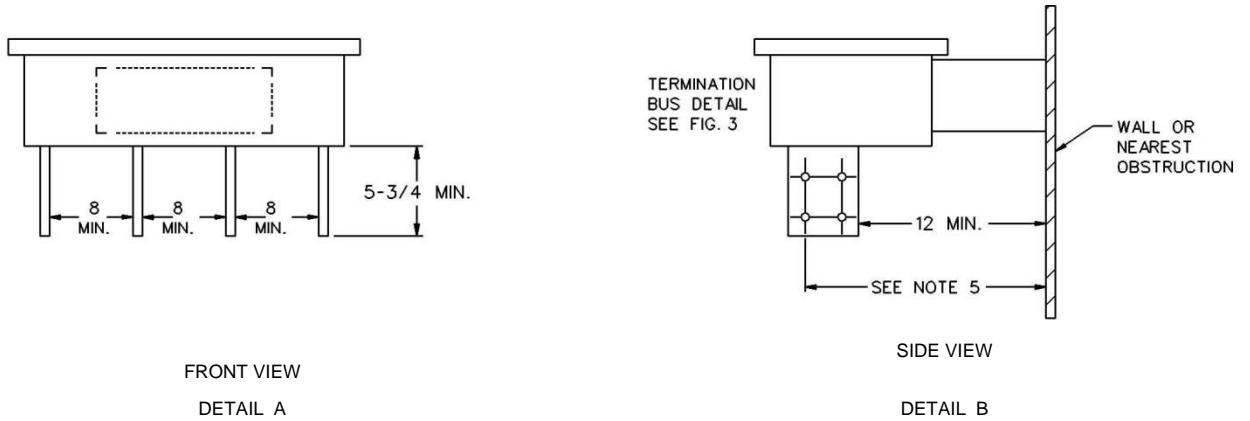

FIGURE 1

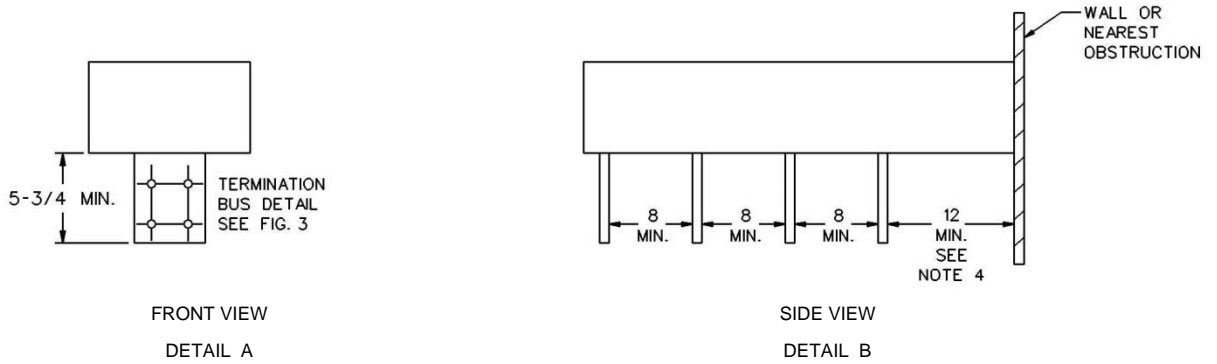
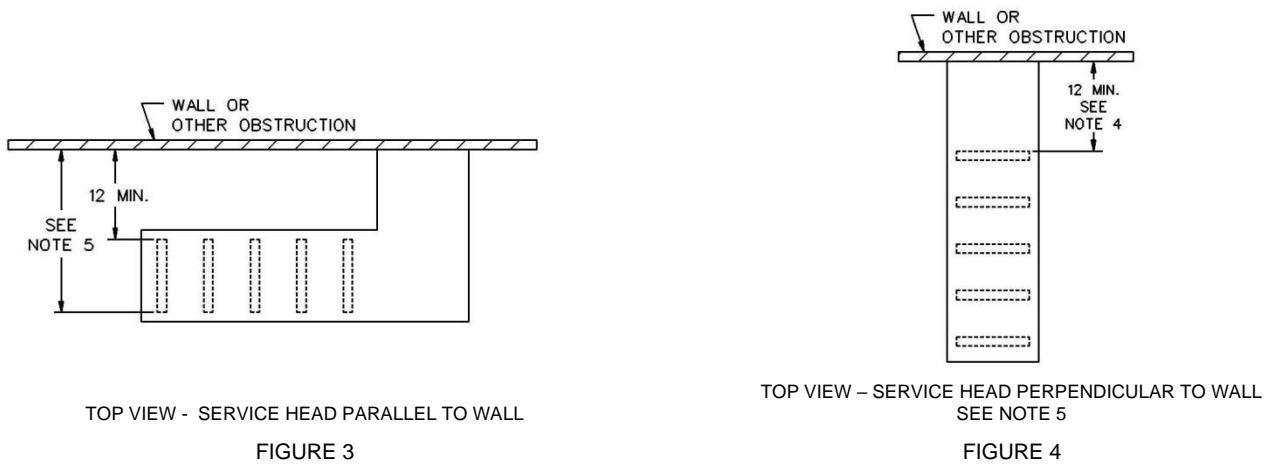
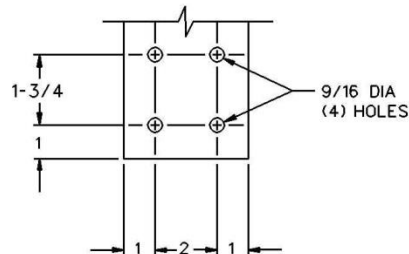

FIGURE 2



BUSWAY SERVICE HEADS (Cont.)

DRILLING TERMINAL FOR LANDING TERMINALS
(1600 AMPERE TERMINAL SHOWN)
SEE NOTES 1,2 AND 3

FIGURE 3

NOTES:

1. One terminal landing position is required for each 800 amperes of service ampacity or fraction thereof (i.e., one position for up to 800 amperes, two positions for 801 amperes through 1600 amperes, three positions for 1601 amperes through 2400 amperes, etc.). Each landing position shall consist of two 9/16-inch holes spaced on 1-3/4-inch vertical centers. When multiple landing positions are required, the horizontal spacing between landing positions shall be 2 inches (minimum).

Exception: For Customer Station installations, one terminal landing position is required for each 400 amperes of service capacity.

2. The neutral terminal shall be permanently marked by the manufacturer.
3. For 240/120-volt 3Ø 4-wire delta services, the power leg ("C" Ø) terminal shall be permanently marked orange in color by the manufacturer.
4. The neutral terminating bus unit clearance to a wall or other obstruction may be reduced to 7 inches.
5. The maximum dimension from the building wall or nearest obstruction to the outer most landing position shall not exceed 25 inches unless approved by the Department.
6. Service heads shall not be installed with the terminals over any roof or parapet.
7. Service heads with enclosed terminating positions are not permitted.
8. 3Ø 3-wire is not a standard voltage - see page 1-25 for applications and limitations.
9. References:
 - a. For medium-voltage requirements (2400-34500 volts), see page 4-36.

Date: 02-01-03

LOW-VOLTAGE SWITCHBOARDS, 0 - 600 VOLTS

**THIS PAGE LEFT
INTENTIONALLY BLANK**

MEDIUM-VOLTAGE SWITCHGEAR, 2400-34500 VOLTS

Date: 05-02-24

CONTENTS**PAGE**

General Requirements

A. Introduction	4-2
B. Manufacturer's Drawings for Approval	4-2
C. Compartment Barriers	4-2
D. Sealing Requirements	4-2
E. Grounding and Bonding	4-3
F. Service Disconnects	4-3
G. Compartment Labeling	4-3
H. Ventilation Openings	4-3

Metering Enclosure, 2400-4800 Volts	4-5
-------------------------------------	-----

A. Applications and General Enclosure Requirements	4-5
B. Current-Transformer Compartment	4-7
C. Voltage-Transformer Compartment	4-7
D. Voltage-Transformer Disconnect Switch	4-8
E. Voltage-Transformer Fuses	4-8
F. Meter Panels	4-8
G. Additional References	4-8

Hinged Meter Panel	4-10
--------------------	------

Alternate Meter Panel Arrangement	4-12
-----------------------------------	------

Instrument-Transformers and Mounting Requirements:

A. Current-Transformers	4-14
B. Current-Transformer Bus Spacing and Mounting Requirements	4-15
C. Current-Transformer Mounting Base Detail	4-16
D. Voltage-Transformer Mounting Rails Detail	4-16

Underground Service Terminating Enclosure, 2400-4800 Volts 3Ø 3-Wire	4-18
--	------

Metering Enclosure, 34,500 Volts 3Ø 3-Wire

A. Applications and General Enclosure Requirements	4-21
B. Voltage-Transformer and Fuse Compartments	4-22
1. Voltage-Transformer Disconnect Switch	4-23
2. Voltage-Transformer Compartment	4-24
3. Voltage-Transformer Fuse Compartment	4-25
C. Current-Transformer and Metering Compartments	4-26
1. Current-Transformer Compartment	4-26, 4-27, 4-28
2. Metering Compartment	4-26, 4-27, 4-29

Voltage Transformers and Mounting Base Details, 34,500 Volts 3Ø 3-Wire	4-30
--	------

A. Voltage Transformers	4-30
B. Voltage Transformer Mounting Base Detail	4-31

Current Transformers and Mounting Base Details, 34,500 Volts 3Ø 3-Wire	4-32
--	------

A. Current transformers	4-32
B. Current Transformer Mounting Base Detail	4-33

Underground Service Terminating Enclosure, 34,500 Volts 3Ø 3-Wire	4-34
---	------

Busway Service Heads, 2400-34500 Volts 3Ø 3-Wire	4-36
--	------

Date: 10-01-25

MEDIUM-VOLTAGE SWITCHGEAR, 2400-34500 VOLTS**GENERAL REQUIREMENTS****A. INTRODUCTION**

The following information provided under General Requirements applies to all 2400 volt, 4160 volt, 4800 volt and 34,500 volt metering enclosures. For additional requirements for services metered at:

1. For 2400, 4160 and 4800-volts, see pages 4-5 through 4-19, and 4-36.
2. For 34,500 volts, see page 4-21 through 4-36.
3. For services metered at other voltages, consult the Customer Station Design Group regarding service and metering installation requirements. See page 1-4 for office location and telephone numbers.

B. MANUFACTURER'S DRAWINGS FOR APPROVAL

1. Customers are required to consult the Department regarding all new switchgear installations and changes in metering due to load additions or modifications to existing services.
2. A manufacturer's equipment drawing shall be submitted to the Department before fabricating all switchgear rated over 600 volts.
3. Approval drawings shall provide the following information:
 - a. Job Address (not delivery address).
 - b. Manufacturer's contact with email address, telephone and fax number.
 - c. Voltage, ampacity and short-circuit rating information.
 - d. Details of the equipment with panel layout, sectional view layout with dimensions, and meter socket provisions with appropriate ESR or EUSERC page references. Single-line type drawings are not acceptable.
 - e. Any other information deemed necessary by the Department for approval of the manufacturer's drawing.
 - f. Separate drawings shall be submitted for busways and busway service heads, see page 4-36.
4. Email copies of the switchgear drawings to the Customer Station Design Group (Attention: Switchgear Review).
5. Switchgear approvals shall remain in effect for no more than 18 months after which time new drawings shall be resubmitted for approval.

C. COMPARTMENT BARRIERS

1. Utility metering, fuse, voltage transformer, current-transformer and service terminating compartments shall be fully enclosed and include barriers that are secured with devices (carriage bolts or equivalent) that are not removable from either the customer sections or the exterior of the switchgear.
2. Where full BIL insulated cables or busses pass through compartment walls, a full voltage and BIL insulation system shall be used, unless otherwise approved by the Department.

D. SEALING REQUIREMENTS

1. Where sealing is specified in this section, hinged doors or panels shall be sealed on the side opposite the hinges using either sealing screws or captive stud assemblies.
2. Captive stud assemblies shall consist of a 1/4-inch-20 (minimum) stud and associated wing nut, each drilled 0.0635-inch (minimum) for sealing purposes. The stud shall be securely attached so as to not loosen or back out when being fastened.

GENERAL REQUIREMENTS**E. GROUNDING AND BONDING**

1. Manufacturers shall not provide a termination lug for the customer's grounding conductor in any compartment sealed or locked by the Department unless specifically required by the City of Los Angeles Electric Code or other applicable codes.
2. Conduit bonding jumpers, when required, shall be terminated at the closest available point where the conduit to be bonded enters an underground terminating enclosure or metering compartment.

F. SERVICE DISCONNECTS

1. The manufacturer shall furnish and install a single service disconnect device with overcurrent protection, unless otherwise approved by the Department, on the load side of the meter socket (HOT SEQUENCE) which shall control all of, and only, the energy registered by the meter.
2. The service disconnect shall be capable of being locked in the open (off) position. Locking provisions shall be readily identifiable and accept a standard Department padlock having a 5/16-inch lock shaft and a 1-inch locking clearance.
3. Customer-owned devices shall be located on the load side of the service disconnect with some exceptions, see page 1-39 for requirements.

G. COMPARTMENT LABELING (Manufacturer)

1. Each section of the metering enclosure shall be permanently labeled on the exterior of the enclosure to identify the metered voltage, phase and ampacity rating.
Note: The ampacity rating is the maximum vacuum breaker trip setting or the maximum fuse rating for the main service disconnect device requested by the customer and approved by the Department.
2. Compartments of the metering enclosure shall be permanently labeled with machine engraved laminated phenolic or equivalent tags. Labels shall have 3/8-inch (minimum) white letters and numbers on a red colored background and shall be readily visible and mechanically attached to the face of the following designated compartments and shall read:
 - a. UTILITY-VOLTAGE-TRANSFORMER COMPARTMENT
 - b. UTILITY VOLTAGE-TRANSFORMER FUSE COMPARTMENT
 - c. UTILITY CURRENT-TRANSFORMER COMPARTMENT
 - d. UTILITY METERING COMPARTMENT
 - e. UTILITY SERVICE TERMINATION COMPARTMENT
3. Meter and service equipment shall be provided with a label identifying the nationally recognized testing laboratory (NRTL) that has tested and listed the equipment.

H. VENTILATION OPENINGS

1. Ventilation openings in panel covers and doors with provisions for utility seals or locks shall be protected by internal intrusion resistant metal barriers that are secured with devices that may not be removed from the outside.
2. Filters for ventilation openings (if so equipped) shall be serviceable by the customer without the need to remove utility locks or break utility seals.

Date: 01-01-11

MEDIUM-VOLTAGE SWITCHGEAR, 2400-34500 VOLTS

**THIS PAGE LEFT
INTENTIONALLY BLANK**

METERING ENCLOSURE, 2400-4800 VOLTS

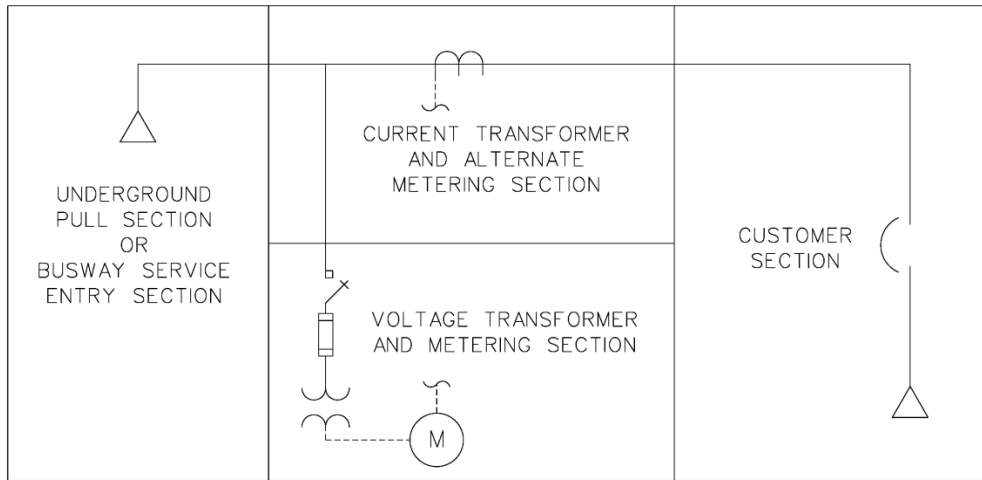

PLAN VIEW

TYPICAL METER ENCLOSURE COMPARTMENT LAYOUT

NOTES (Drawing, page 4-6):

A. APPLICATIONS AND GENERAL ENCLOSURE REQUIREMENTS

1. In general, bus spacing in enclosure compartments is to be determined by the manufacturer, certified and labeled to a minimum ANSI/IEEE C37.20.2/.3 by an NRTL that is acceptable to the City of Los Angeles for this class of equipment.

Exception: Bus spacing as determined by the Department applies to work spaces around current transformers, voltage transformers, fuses and cable terminations. Unless otherwise specified in these requirements, the minimum bare bus clearances shall be 5" phase to phase and 3-1/2" phase to ground.

2. The B.I.L (Basic Impulse Level) for the meter enclosure shall not be less than 60kV.
3. The metering enclosure is shown as a weatherproof (NEMA-3R) enclosure with hinged exterior doors. The exterior doors shall be:
 - a. Hinged on the side opposite of the meter door to allow the meter door to open 90-degrees with the Department's meter and test switch installed.
 - b. Equipped with a full hand grasping, single handle-operated latching system equipped with locking provisions to accept a standard Department padlock (5/16-inch lock shaft and 1-inch locking clearance).
 - c. Equipped with durable devices to hold the doors in the open position at 90-degrees or more. The devices shall be permanently attached to either the enclosure or the doors and may be either automatic or manual but shall not require disassembly to operate.

Note: The exterior doors and associated side panels may be omitted for indoor (NEMA 1) installations.

4. See GENERAL REQUIREMENTS on page 4-2 and 4-3 for additional information.

Date: 10-31-18

MEDIUM-VOLTAGE SWITCHGEAR, 2400-34500 VOLTS

EUSERC DWG. 401

ALL DIMENSIONS SHOWN ARE IN INCHES

METERING ENCLOSURE, 2400-4800 VOLTS

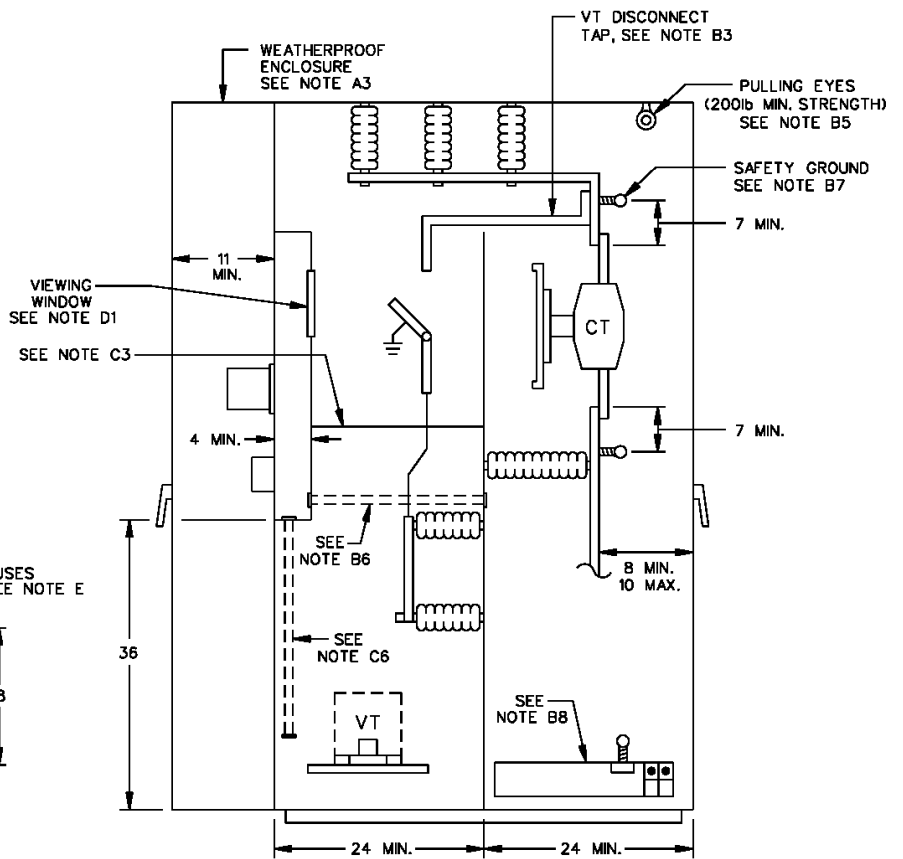
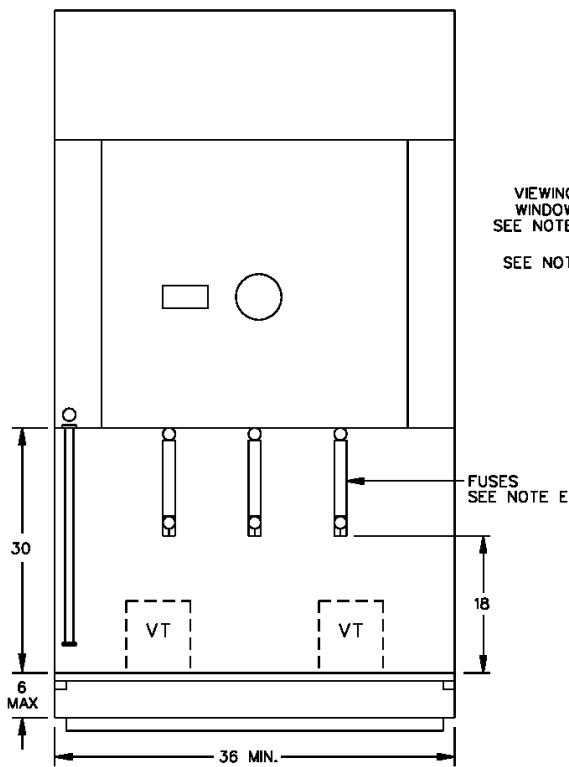
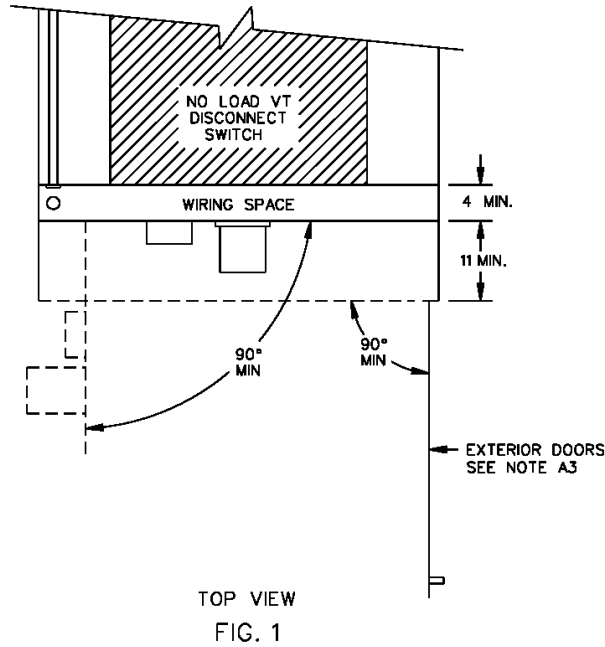

METERING ENCLOSURE, 2400-4800 VOLTS**NOTES (Cont.):****B. CURRENT-TRANSFORMER COMPARTMENT**

1. **THE CURRENT-TRANSFORMER COMPARTMENT SHALL NOT BE USED TO TERMINATE THE DEPARTMENT'S SERVICE SUPPLY CONDUCTORS.**
2. The current-transformer bus units shall be drilled and spaced to accept the Department's current transformers and permit installation and removal of individual transformers without disturbing adjacent transformers. The area in front of the current-transformer bus units shall be clear of all fixed panels, bracing and bus supports to permit unobstructed access to current transformers and safety grounds. See page 4-14 for instrument-transformers and mounting requirements.
3. Taps to the voltage-transformer disconnect switch shall be made on the line (supply) side of the current transformers.
4. The center (BØ) current-transformer bus unit shall be continuous and located on the same vertical plane as the other current-transformer bus units.
Note: A removable link may be used on the center bus in place of a single continuous bus unit.
5. Provide a lifting eye above each current transformer position as shown. Each eye shall support a minimum weight of 200 pounds.
6. Provide a 1" conduit for secondary wiring from the current-transformer compartment as shown. The conduit shall be on the same side as the meter panel hinges.
7. Ball studs (1/2"-13 threads with insulating covers) for the attachment of safety grounds shall be provided on the line and load side of the current-transformer (CT) bus units. The studs shall be located not less than 7" from the end of the bus unit and oriented toward the compartment access opening.
8. The ground bus shall extend to either the front left or right sides of the CT compartment and shall be provided with grounding terminals for use with the ball studs or ground bails. The terminals shall consist of a single ball stud (1/2"-13 threads with insulating cover) or a ground bail (1/2 x 15-inch minimum) and two aluminum-bodied mechanical lugs accepting a range of no. 6 through 250 KCMIL conductors and shall be identified with a label reading "SAFETY GROUNDING POINT FOR UTILITY USE ONLY".
Note: All ball studs or ground bails shall be positioned to allow the use of hot sticks to install and remove the utility grounding harness and shall not be obstructed or blocked by fixed panels.
9. The customer shall not make any wiring connections or install any devices in the current-transformer compartment except for heating elements specified and supplied by the manufacturer.

Date: 05-02-24

MEDIUM-VOLTAGE SWITCHGEAR, 2400-34500 VOLTS

METERING ENCLOSURE, 2400-4800 VOLTS**C. VOLTAGE-TRANSFORMER COMPARTMENT**

1. The voltage-transformer compartment cover shall be lockable with a Kirk key interlock system so that, for personnel safety, the door cannot be opened without first opening the VT disconnect switch.
2. The width of the voltage-transformer compartment access opening shall permit unobstructed access to the voltage transformers.
3. A full width and depth horizontal insulated barrier shall be provided to isolate the disconnect switch from the voltage transformer compartment.
4. Mounting rails (Unistrut P-1000 or equivalent) shall be provided for the installation of the Department's voltage transformers. The mounting holes in the front rail shall be 9 inches from the voltage-transformer compartment cover. See page 4-16 for voltage-transformer mounting rail details.
5. Terminals for the voltage-transformer phase connections shall be provided on the load side of the fuse mounting clips at a minimum height of 18 inches above the top of the voltage-transformer mounting rails. The terminals shall be drilled for 1/4-inch - 20 x 3/4-inch bolts. All bolts and associated hardware shall be included and plated to prevent corrosion.
6. Provide a 1" conduit for secondary wiring from the voltage-transformer compartment as shown. The conduit shall be on the same side as the meter panel hinges.
7. The customer shall not make any wiring connections or install any devices in the voltage-transformer compartment except for heating elements specified and supplied by the manufacturer.

D. VOLTAGE-TRANSFORMER DISCONNECT SWITCH

1. Manufacturers shall provide a 3-pole, gang-operated disconnect switch to de-energize the voltage transformers. In the fully open (off) position, the switch shall provide a visible air gap to verify successful disconnect and the disconnect blades shall visibly and automatically ground.
Note: A viewing window shall be provided so that the switch position, open and grounded or closed, may be confirmed.
2. The primary contacts for the voltage-transformer disconnect switch shall be of the blade and jaw design (or equivalent) to assure continued adequate blade contact. Wiping contact or pressure contact designs are not acceptable.
3. The voltage-transformer disconnect switch cover shall be independent of the VT compartment door and shall barrier all energized parts when the voltage-transformer compartment door is open.
4. The voltage-transformer disconnect switch operating handle shall be lockable in the closed (on) position using a standard Department padlock (5/16-inch lock shaft and a 1-inch locking clearance).
5. A Kirk key interlocking system shall be provided for the voltage-transformer disconnect switch and the voltage-transformer compartment door so that, for personnel safety, the voltage-transformer compartment cannot be entered until the switch is fully opened, visibly grounded and locked in the open position with the interlock system.
Note: The manufacturer shall supply two keys for the interlock system. One key stays in the voltage-transformer disconnect switch and one key will be retained by the Department as a spare.
6. The interlock system shall prevent closing of the voltage-transformer disconnect switch without first closing and locking the voltage-transformer compartment cover.
7. Upon request, the manufacturer shall provide the Department with a functionality test report verifying durability and electrical continuity of the switch grounding provisions.

METERING ENCLOSURE, 2400-4800 VOLTS**E. VOLTAGE-TRANSFORMER FUSES**

1. Manufacturers shall provide three fuse holders for mounting indoor current-limiting fuses for the protection of the voltage transformers (VT). Each fuse holder shall be provided with two mounting clips having a separation of 8-1/2 inches (measured from clip centers) and accepting a fuse ferrule diameter of 1-5/8 inches.
2. The manufacturer shall bus or wire from the VT switch to the fuse holders.
3. The Department shall furnish and install the fuses and wire from the fuse holders to the voltage transformers.

F. METER PANELS

1. The standard meter socket location is in front of the voltage-transformer disconnect switch. For meter panel details see page 4-10.
2. The alternate meter socket location is on the current-transformer compartment door. For meter panel details and related requirements, see page 4-12.

G. ADDITIONAL REFERENCES

1. For installation (clearance and access) requirements, see page 5-16.
2. For sealing requirements, see page 4-3.
3. For lifting handle requirements, see page 4-2.
4. For bonding and grounding requirements, see page 4-3
5. For underground terminating pull section requirements, see page 4-18.

HINGED METER PANEL
2400-4800 VOLTS, 3Ø 3-WIRE

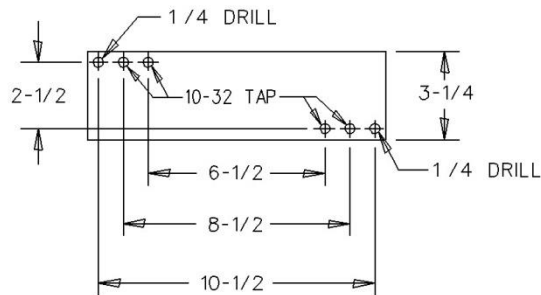
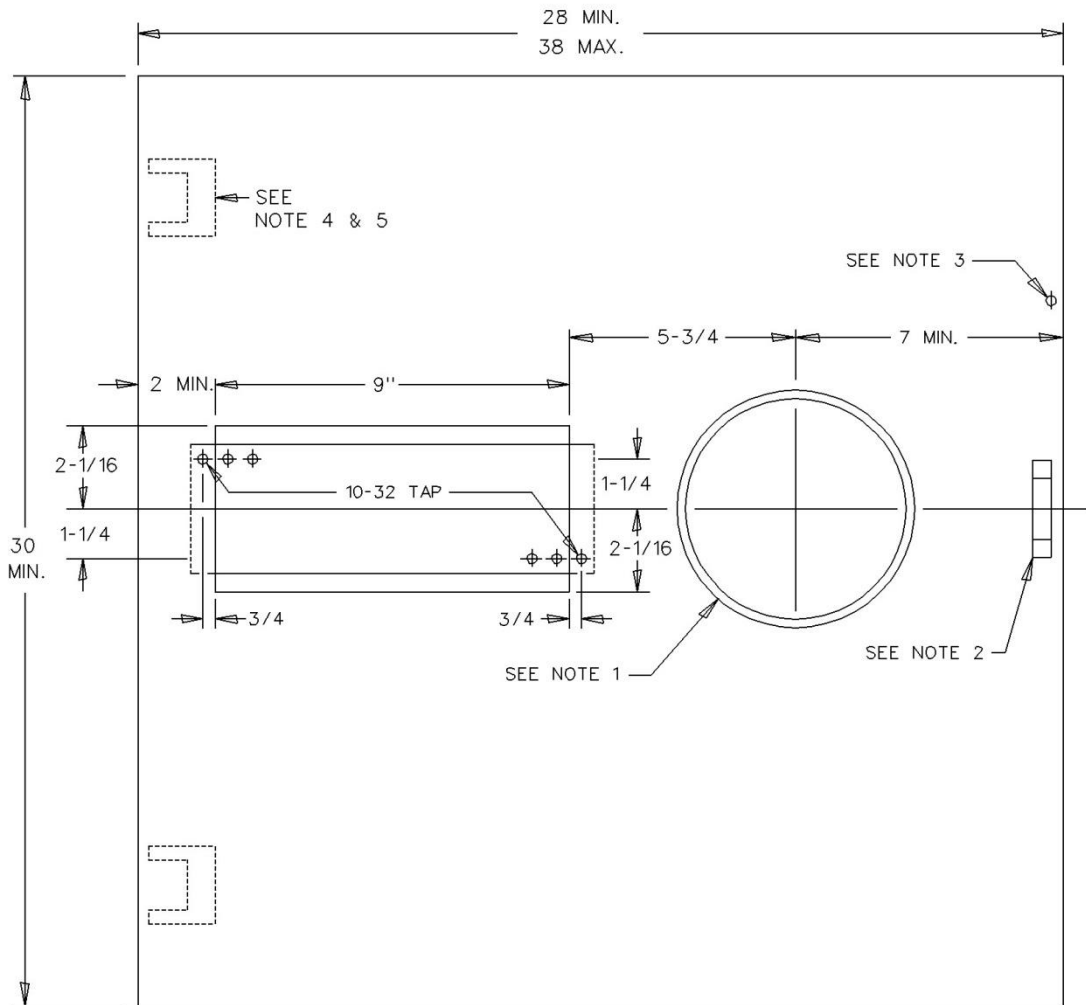

REMOVABLE (TEST SWITCH)
MOUNTING PLATE DETAIL

MEDIUM-VOLTAGE SWITCHGEAR, 2400-34500 VOLTSDate: 01-01-01

HINGED METER PANEL (Cont.)
2400-4800 VOLTS, 3Ø 3-WIRE**NOTES:**

1. The panel shall be constructed of 12-gauge (minimum) steel and furnished with a meter ring, meter socket, sealing ring and a slotted opening with a removable plate for installation of a meter test switch. The plate shall be attached to the rear of the panel with screws that do not protrude through the face of the panel. The edges of the plate and the slotted opening shall be smooth to prevent damage to the meter wiring.
2. The panel shall be hinged on the test switch side and shall open to 90-degrees (minimum) with the meter and test switch installed. Clevis or removable pin type hinges shall be removable from the top.
3. The panel shall have a handle attached to the side opposite the hinges and the handle shall not be less than 1-inch from the meter socket ring.
4. The panel shall be sealable on the side opposite the hinges.
5. The panel shall be bonded to the switchboard enclosure with a flexible, braided wire installed across the hinges.
6. The panel shall support a 25-pound force applied at the unsupported end of the panel when fully opened with a maximum sag of 1/8 inch.
7. Meter sockets shall be back connected and shall have either an 8-clip or 15-clip arrangement as specified for 3Ø 3-wire metering applications and be listed by Underwriters Laboratories (UL) and meet ANSI Standard C-12.7. The socket clips shall be made from beryllium copper.

Note: Screws used to mount cast meter sockets to the meter panel shall provide a 1/8" minimum clearance between the screw head and the back of the meter socket ring.

8. References:
 - a. For meter panel applications, see page 4-6.
 - b. For meter socket clip arrangements, see page 2-5.
 - c. For sealing requirements, see page 4-3.
 - d. For lifting handle requirements, see page 4-3.

ALTERNATE METER PANEL ARRANGEMENT
2400-4800 VOLTS, 3Ø 3-WIRE

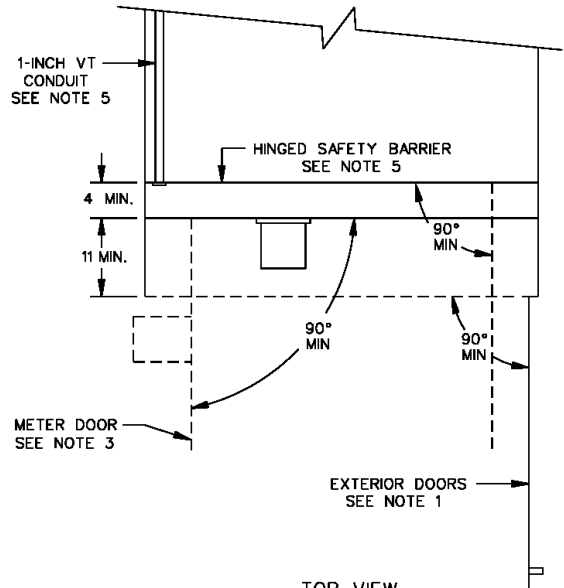

TOP VIEW
FIG. 1

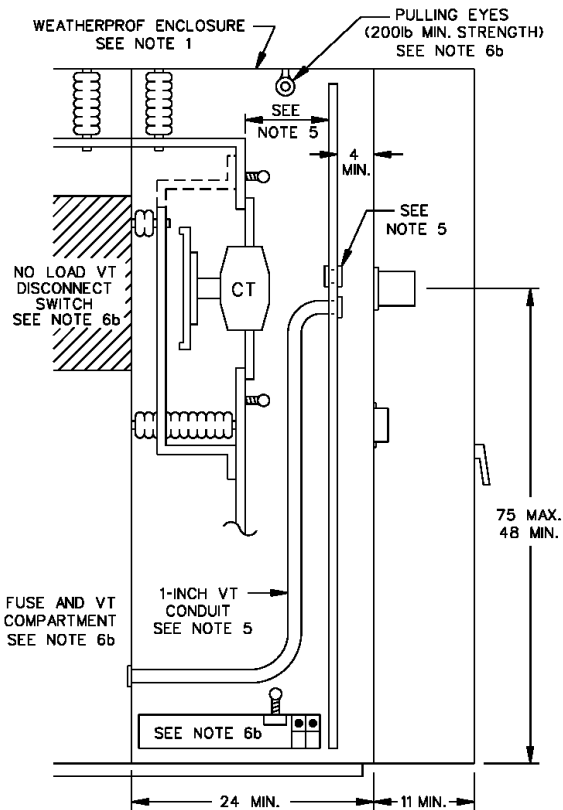

SIDE VIEW
FIG. 2

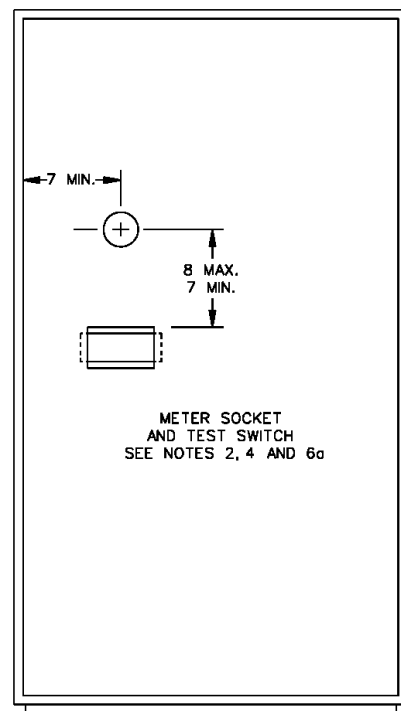

FRONT VIEW
FIG. 3

ALTERNATE METER PANEL ARRANGEMENT (Cont.)
2400-4800 VOLTS, 3Ø 3-WIRE**NOTES:**

1. The alternate meter panel arrangement is shown in a weatherproof enclosure with an exterior door. The exterior door shall be:
 - a. Hinged and equipped with a full grasping, single handle-operated latching system with locking provisions to accept a standard Department padlock having a 5/16-inch lock shaft with a 1-inch locking clearance.
 - b. Equipped with durable devices to hold the door open at 90-degrees or more. The devices shall be permanently attached to either the enclosure or the doors and may be automatic or manual but shall not require disassembly to operate.
2. The meter panel shall be a single, full-height door constructed of 12-gauge (minimum) steel and furnished with a meter ring, meter socket, sealing ring and a slotted opening with a removable plate for installation of a test switch. The plate shall be attached to the rear of the panel with screws that do not protrude through the face of the door. The edges of the plate and the slotted opening shall be smooth to prevent damage to the meter wiring. See page 4-10 for meter socket, test switch cutout and removable plate details.
3. The meter door shall:
 - a. Be hinged and shall open to 90-degrees or more with the meter and test switch installed.
 - b. Be equipped with durable devices to hold the door in the fully open position. The devices shall be permanently attached to either the enclosure or the door and may be automatic or manual but shall not require disassembly to operate.
 - c. Have a handle attached on the side opposite the hinges. The handle shall be sized for full hand grasping.
Note: For applications where the meter door is the exterior door, the door shall have a single handle-operated latching system and be lockable with a Department padlock having a 5/16" lockshaft and a 1" locking clearance.
 - d. The panel shall be bonded to the switchboard enclosure with a flexible, braided wire installed across the hinges.
4. The meter socket shall be back connected and have either an 8-clip or 15-clip arrangement as specified for 3Ø 3-wire metering applications. The socket jaws shall be made from beryllium copper; be listed by Underwriters Laboratories (UL) and meet ANSI Standard C-12.7.
Note: Screws used to mount cast meter sockets to the meter panel shall provide a 1/8" minimum clearance between the screw head and the back of the meter socket ring.
5. A full height perforated or expanded metal screen hinged safety barrier shall be provided to isolate the current-transformer compartment from the meter panel. The barrier shall be hinged and must fully close with the Department's current-transformers installed without the barrier contacting the transformers.
Note: A 1-inch conduit for the VT wiring and a 1-inch grommet for the CT wiring shall be installed through a fixed part of the safety barrier on the same side as the meter panel hinges.
6. References:
 - a. For meter socket clip arrangements and details, see page 2-5.
 - b. For additional metering enclosure requirements, see page 4-6.

Date: 01-01-10

MEDIUM-VOLTAGE SWITCHGEAR, 2400-34500 VOLTS

EUSERC DWG. 407

ALL DIMENSIONS SHOWN ARE IN INCHES

INSTRUMENT-TRANSFORMERS AND MOUNTING REQUIREMENTS
2400-4800 VOLTS, 3Ø 3-WIRE

A. CURRENT TRANSFORMERS

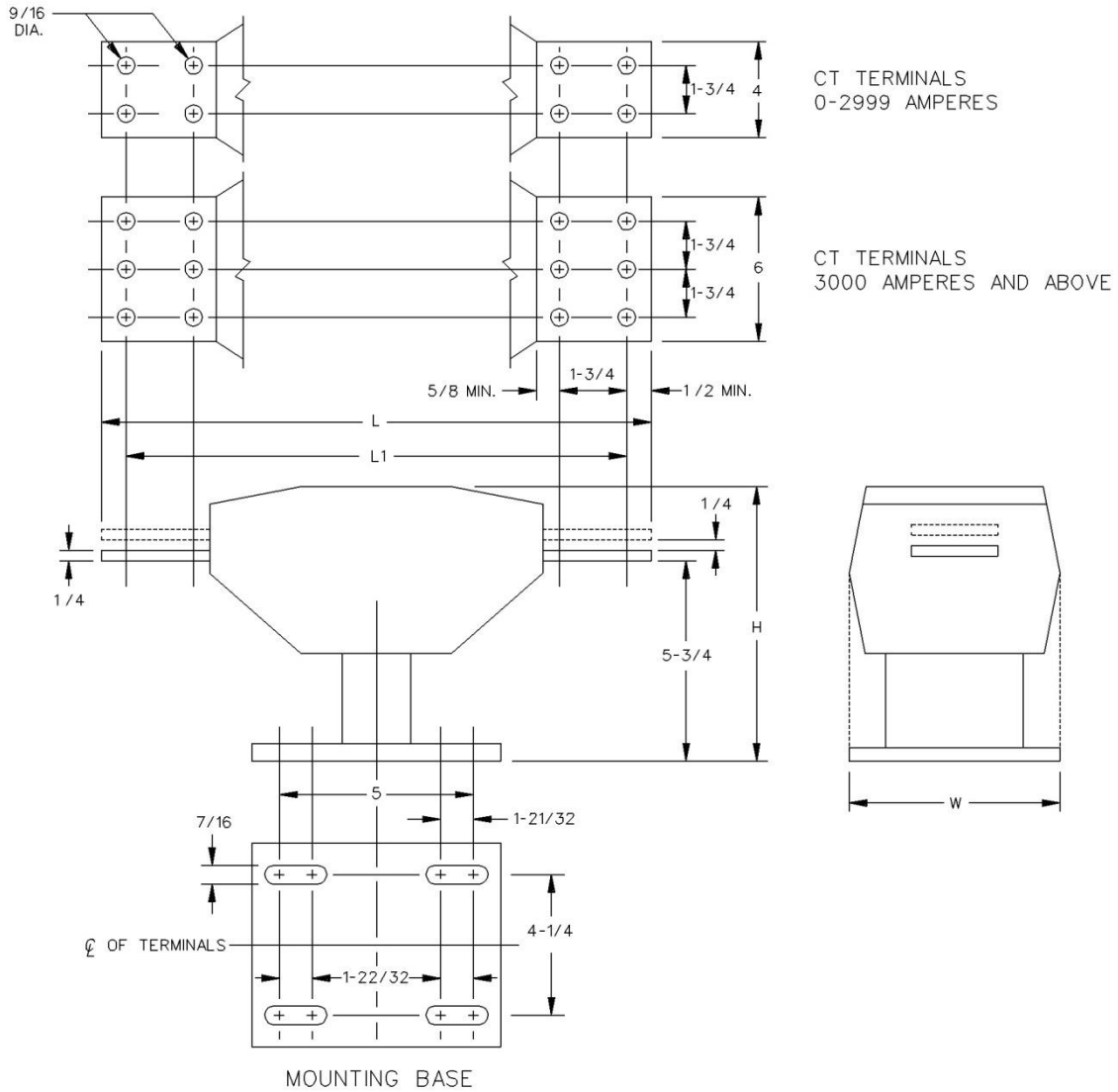

TABLE 1

SWITCHBOARD RATING (amperes)	CT TYPE	L	L1	H	W	TERMINAL PADS	
						NO. OF PADS	HOLES PER PAD
0-1200	JCM-4	16	15	11-11/16	9-1/2	1	4
1201-2999	JCM-4	16	15	12-3/16	9-1/2	2	4
3000 AND ABOVE	JCM-4	16	15	12-7/16	9-1/2	3	6

Note: Current-transformer terminal pads are constructed of 1/4-inch bus and multiple pads are spaced 1/4 inch. Switchgear designs must assure that all of the current-transformer bus units are in contact the current-transformer terminal pads. Removable bus spacers are not permitted.

INSTRUMENT-TRANSFORMERS AND MOUNTING REQUIREMENTS (Cont.)
2400-4800 VOLTS, 3Ø 3-WIRE

B. CURRENT-TRANSFORMER BUS SPACING AND MOUNTING REQUIREMENTS

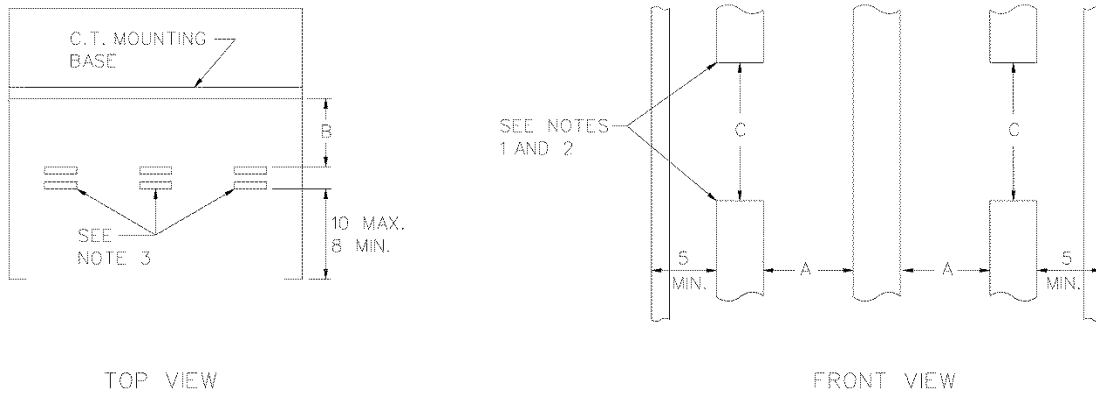

CURRENT-TRANSFORMER COMPARTMENT BUS SPACING DETAIL

TABLE 2			
SERVICE DISCONNECT RATING (amperes)	BUS CLEARANCES (inches) *		
	"A"	"B"	"C"
0-1200	7 MIN.	6	10-1/2 MIN.
1201-2999	7 MIN.	5-1/2	
3000 AND ABOVE	8 MIN.	5-1/2	

*Unless otherwise indicated, tolerance is plus or minus 1/16 inch

NOTES:

- The current-transformer bus units shall be drilled to accept the current-transformers (CT) specified and shall be provided with 1/2-inch bolts and associated spring washers and nuts for mounting the CTs. The spring washer may be either a cone-type (Belleville) washer or a flat washer with a split ring washer. All parts shall be plated to prevent corrosion.
Note: When conical washers are used, the manufacturer shall provide a readily visible label in the compartment clearly identifying the recommended torque setting for the bolt assemblies used with the washers. The label shall not be installed on removable or hinged access cover panels.
- The upper and lower current-transformer bus units shall be sized to accept the current-transformers specified, be vertically aligned and provide for contact by all of the bus units with all of the current-transformer terminal pads.
- Current-transformer bus units for switchboards rated up to 1200 amperes shall be constructed of a single 1/4-inch bus. Laminated current-transformer bus units for switchboards rated 1201 amperes and above shall be constructed of 1/4-inch bus spaced 1/4 inch apart to accept the specified current-transformer Switchgear designs must assure that all of the current-transformer bus units are in contact with the current-transformer terminal pads. Removable bus spacers are not permitted.

Date: 01-01-10

MEDIUM-VOLTAGE SWITCHGEAR, 2400-34500 VOLTS

EUSERC DWG. 407

ALL DIMENSIONS SHOWN ARE IN INCHES

INSTRUMENT-TRANSFORMERS AND MOUNTING REQUIREMENTS (Cont.)
2400-4800 VOLTS, 3Ø 3-WIRE

C. CURRENT-TRANSFORMER MOUNTING BASE DETAIL

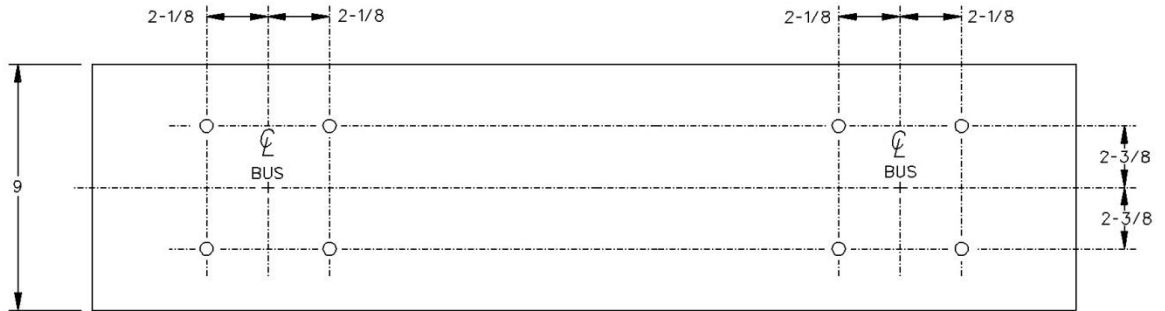

ALL HOLES TAPPED 3/8-16

D. VOLTAGE-TRANSFORMER MOUNTING BASE DETAIL

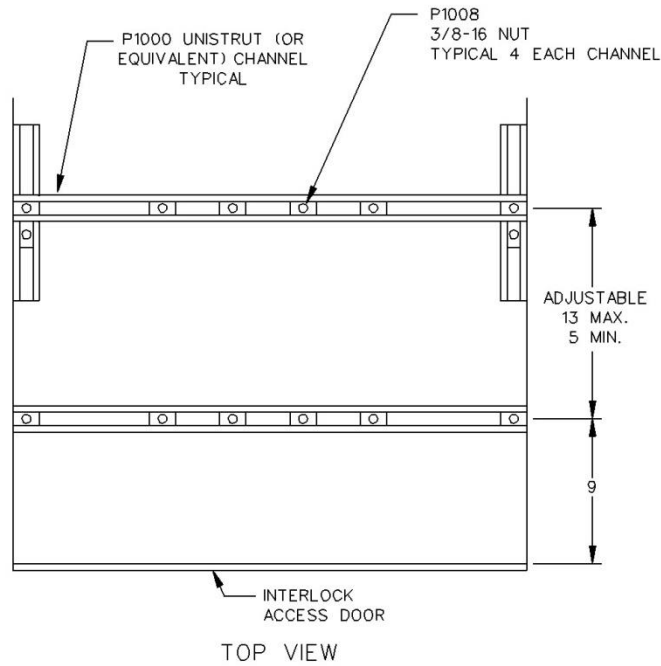

MEDIUM-VOLTAGE SWITCHGEAR, 2400-34500 VOLTSDate: 02-01-03

**THIS PAGE LEFT
INTENTIONALLY BLANK**

UNDERGROUND SERVICE TERMINATING ENCLOSURE
2400-4800 VOLTS, 3Ø 3-WIRE

Minimum bare bus clearances 3-1/2" Ø to Ground, 5" Ø-Ø

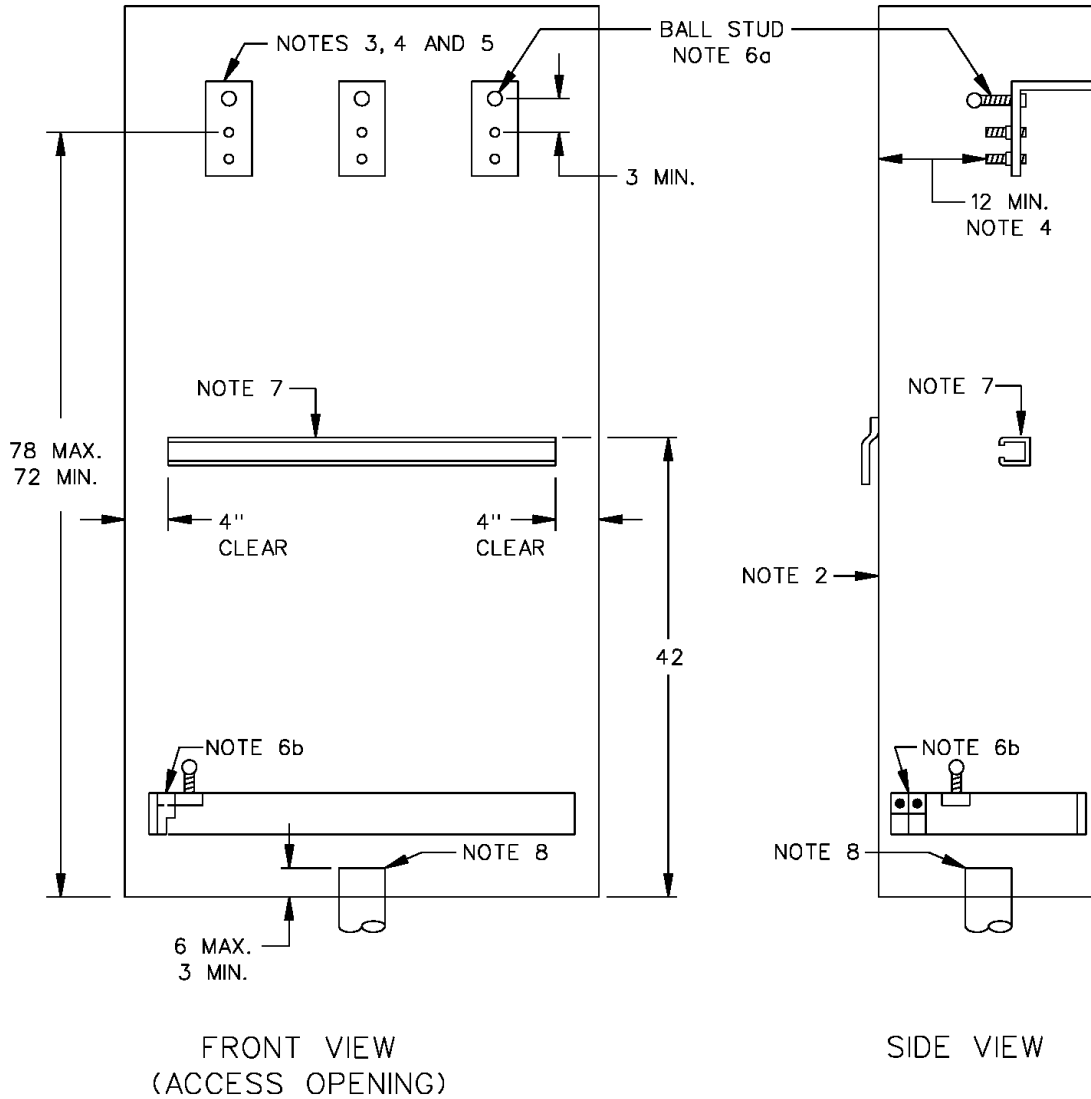

FRONT VIEW
(ACCESS OPENING)

SIDE VIEW

NOTES:

1. For services exceeding 4800 volts, see page 4-34.
2. The pull section shall be provided with a full height hinged single or double doors. The doors shall be:
 - a. Hinged and equipped with a full grasping, single handle-operated latching system with locking provisions to accept a standard Department padlock (5/16-inch lock shaft and 1-inch locking clearance).
 - b. Equipped with durable devices to hold the doors in the open position at 90-degrees or more. The devices shall be permanently attached to either the enclosure or the doors and may be either automatic or manual but shall not require disassembly to operate.

MEDIUM-VOLTAGE SWITCHGEAR, 2400-34500 VOLTSDate: 05-02-24

UNDERGROUND SERVICE TERMINATING ENCLOSURE (Cont.)
2400-4800 VOLTS, 3Ø 3-WIRE

3. Cable terminating facilities shall be provided for the Department's service supply conductors as follows:
 - a. One landing position shall be provided for each 400 amperes of service ampacity (i.e., one position for up to 400 amperes, two positions for 401 through 800 amperes, three positions for 801 through 1200 amperes, etc.).
 - b. Each landing position shall consist of two 1/2-inch steel bolts. The bolts shall extend from 1-1/4 inches to 1-1/2 inches from the mounting surface and be spaced on 1-3/4 inch vertical centers. When multiple landing positions per phase are required, the horizontal spacing between hole positions shall be a minimum of 4 inches to accommodate Department-installed stress cones.

Note 1: Bolts and associated hardware shall be plated to prevent corrosion.

Note 2: When approved by the Department, edgewise-terminating facilities may consist of two 9/16-inch holes spaced on 1-3/4-inch vertical centers in place of the studs.
 - c. The terminating facilities shall be centered relative to the compartment access opening and shall be permanently identified by the manufacturer with the phase designations in clearly visible block lettering.
 - d. The minimum clear compartment access opening width shall be 42-inches.
4. Bare bus clearances shall be a minimum of 12 inches from any phase bus to a removable access cover panel.

Note: The clearance to the access cover panel may be reduced to 3-1/2 inches if a full-height hinged door is provided. See note 2.
5. The edge of any bus support, when provided, shall be located a minimum of 1-inch above the centerline of the top terminating bolts to allow proper seating of the Department's supply cable lugs.
6. Facilities for safety grounding shall be provided as follows:
 - a. A ball stud (1/2"-13 thread with an insulating cover) for the attachment of safety grounds shall be provided on each phase termination bus. The ball stud shall be oriented to face the compartment access opening and positioned so that the hot stick and grounding hardware will not cross over phase bus units during the installation process.
 - b. The ground bus shall extend to either the front left or right sides and shall be provided with grounding terminals for use with the ball studs or ground bails. The terminals shall consist of a single ball stud (1/2"-13 threads with insulating cover) or a ground bail (1/2 x 15-inch minimum) and two aluminum-bodied mechanical lugs accepting a range of no. 6 through 250 KCMIL conductors and shall be identified with a label reading "SAFETY GROUNDING POINT FOR UTILITY USE ONLY".

Note: All ball studs or ground bails shall be positioned to allow the use of hot sticks to install and remove the utility grounding harness and shall not be obstructed or blocked by fixed panels.
7. Provide one piece of Unistrut P-1000 (or equivalent) channel for each set of termination studs. The Unistrut shall be positioned to allow the supply conductors to be secured to the struts without bending the conductors.
8. The Department's service supply conduits shall enter the bottom and be plum, level, square and reasonably centered on the terminating facilities specified in note 3.
9. References:
 - a. For metering enclosure requirements, see page 4-6.
 - b. For sealing requirements, see page 4-3.
 - c. For lifting handle requirements, see page 4-2.
 - d. For bonding and grounding requirements, see page 4-3.

Date: ¹02-03-01

MEDIUM-VOLTAGE SWITCHGEAR, 2400-34500 VOLTS

**THIS PAGE LEFT
INTENTIONALLY BLANK**

METERING ENCLOSURE, 34500 VOLTS 3Ø 3-WIRE

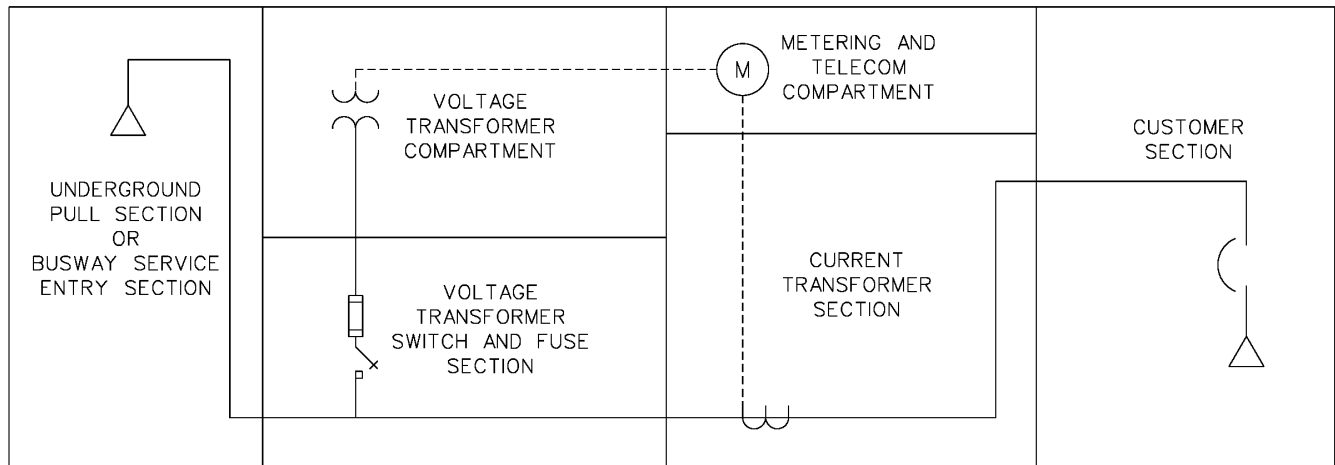

PLAN VIEW

TYPICAL METER ENCLOSURE COMPARTMENT LAYOUT

A. APPLICATIONS AND GENERAL ENCLOSURE REQUIREMENTS

1. The metering enclosure is shown as a weatherproof (NEMA-3R) enclosure with hinged exterior doors and is intended for outdoor applications only and shall be certified and labeled to a minimum ANSI/IEEE C37.20.2/.3 by an NRTL that is acceptable to the City of Los Angeles for this class of equipment.
2. In general, bus spacing in enclosure compartments is to be determined by the manufacturer.
Exception: Bus spacing as determined by the Department applies to work spaces around current transformers, voltage transformers, fuses and cable terminations. Unless otherwise specified in these requirements, the minimum bare bus clearances shall be 15" phase to phase and 10" phase to ground.
3. If approved by the Department, Indoor (NEMA 1) applications of this switchgear shall be of a metal-clad type and utilize a full voltage and full BIL insulated bus system ANSI/IEEE C37.20.2. When available, switchgear shall also be of arc-resistant construction ANSI/IEEE C37.20.7 as appropriate to the location being installed. All hinged exterior access door requirements shown shall also apply to indoor installations.
4. The B.I.L (Basic Impulse Level) for the meter enclosure shall not be less than 150kV.
5. References:
 - a. Voltage-transformer switch requirements, see page 4-23.
 - b. Voltage-transformer compartment requirements, see page 4-22 and 4-23.
 - c. Voltage-transformer fuse compartment requirements, see page 4-22 and 4-25.
 - d. Current-transformer compartment requirements, see page 4-26, 4-27 and 4-28.
 - e. Metering compartment requirements, see page 4-26, 4-27 and 4-29.
 - f. Underground service terminating enclosure requirements, see page 4-34.
 - g. Installation, access and clearance requirements, see page 5-18.

METERING ENCLOSURE, 34500 VOLTS 3Ø 3-WIRE

B. VOLTAGE-TRANSFORMER AND FUSE COMPARTMENTS

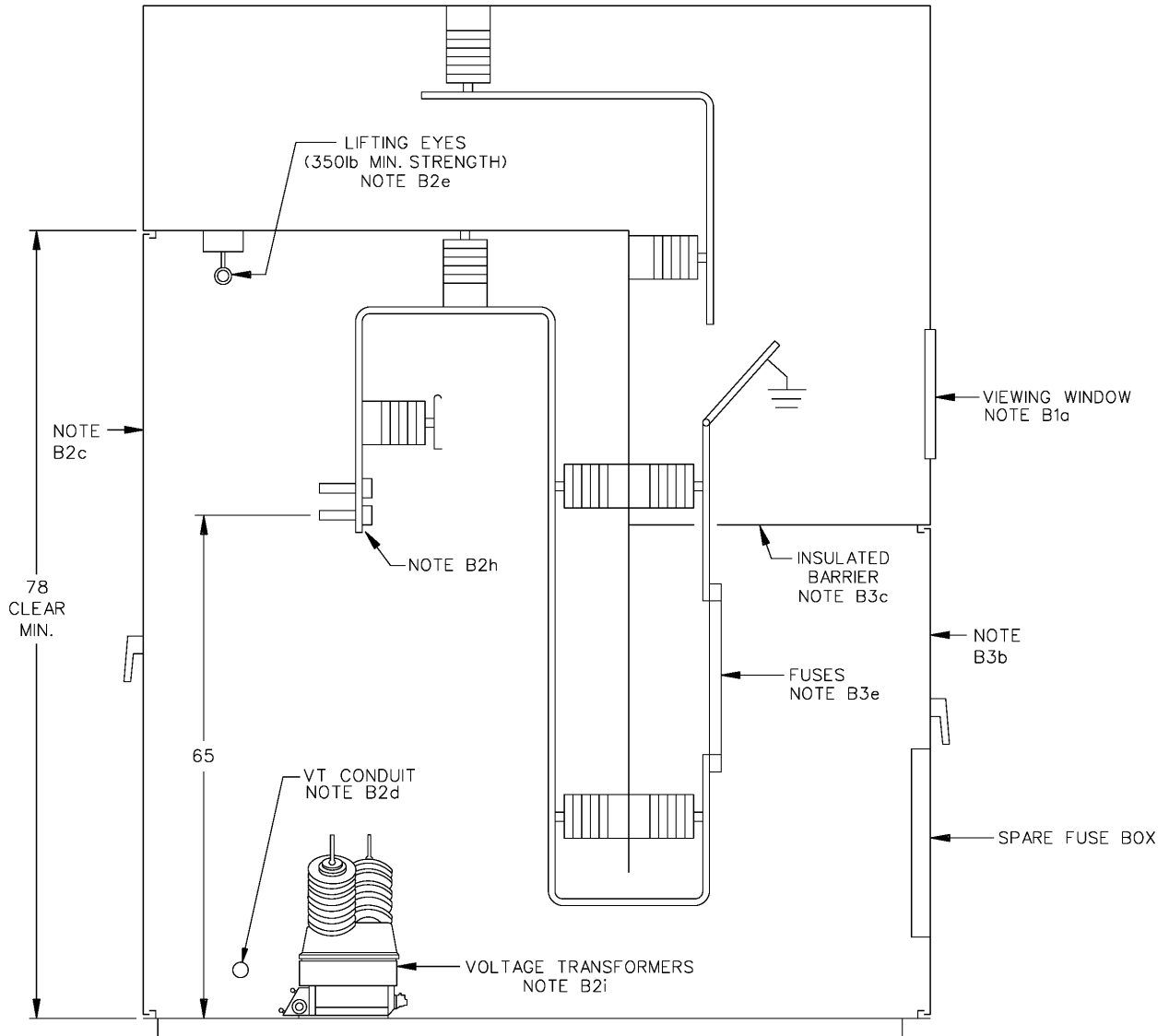

SIDE VIEW

FIG. 1 VOLTAGE TRANSFORMER DISCONNECT, FUSE AND VOLTAGE TRANSFORMER COMPARTMENTS

Note: Minimum bare bus clearances are 10" Ø to Ground, and 15" Ø-Ø in voltage transformer compartment

METERING ENCLOSURE, 34500 VOLTS 3Ø 3-WIRE

B. VOLTAGE-TRANSFORMER AND FUSE COMPARTMENTS (Cont.)

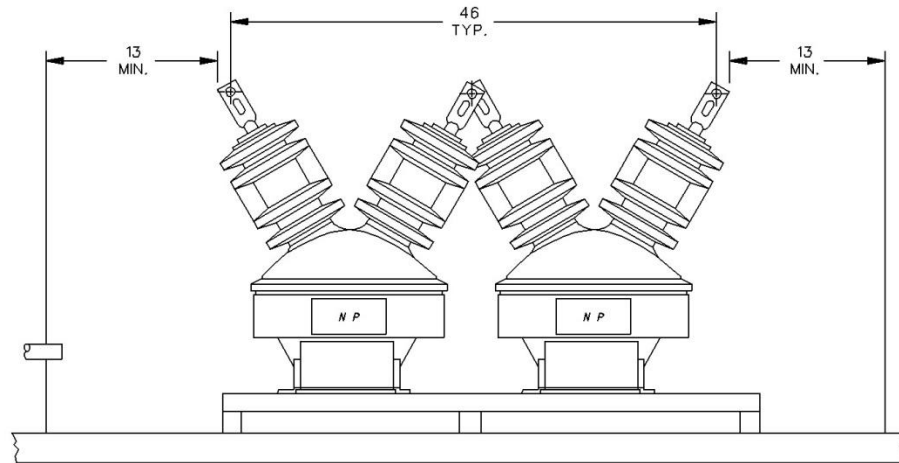

FRONT VIEW

FIG. 2 VOLTAGE TRANSFORMER COMPARTMENT

NOTES:

1. VOLTAGE-TRANSFORMER DISCONNECT SWITCH

- a. Manufacturers shall provide a 3-pole, gang-operated disconnect switch to de-energize the voltage transformers. In the fully open (off) position, the switch shall provide a visible air gap to verify successful disconnect and the disconnect blades shall visibly and automatically ground.

Note 1: A viewing window shall be provided so that the switch position, open and grounded or closed, may be verified.

Note 2: The switch shall be tapped on the supply (utility) side of the metering current transformers.

- b. The primary contacts for the voltage-transformer disconnect switch shall be of the blade and jaw design (or equivalent) to assure continued adequate blade contact. Wiping contact or pressure contact designs are not acceptable.
- c. The voltage-transformer disconnect switch cover shall be independent of the fuse compartment door.
- d. The voltage-transformer disconnect switch operating handle shall be lockable in the closed (on) position using a standard Department padlock (5/16-inch lock shaft and a 1-inch locking clearance).
- e. A Kirk key interlock system shall be provided for the voltage-transformer (VT) disconnect switch, the fuse compartment and voltage-transformer compartment doors. A single key shall be used to interlock the VT switch and the fuse and voltage-transformer compartment doors.

Note: The manufacturer shall supply two keys for the interlock system. One key stays in the voltage-transformer disconnect switch and one key will be retained by the Department as a spare.

- f. Upon request, the manufacturer shall provide the Department with a functionality test report verifying durability and electrical continuity of the switch grounding provisions.

METERING ENCLOSURE, 34500 VOLTS 3Ø 3-WIRE**B. VOLTAGE-TRANSFORMER AND FUSE COMPARTMENTS (Cont.)****2. VOLTAGE-TRANSFORMER COMPARTMENT**

- a. The width of the voltage-transformer compartment access opening shall permit unobstructed access to the voltage transformers.
- b. The voltage transformer compartment shall be fully barriered to isolate the compartment from any energized bus or devices when the voltage-disconnect switch is in the open position.
- c. The compartment doors shall be:
 - 1) Hinged and equipped with a full hand grasping single-handle operated latching system.
 - 2) Equipped with durable devices to hold the doors open at 90-degrees or more. The devices shall be permanently attached to either the enclosure or the doors and may be automatic or manually operated but shall not require disassembly to operate.
 - 3) Lockable with a Kirk key interlock system so that the compartment cannot be entered without first opening the voltage-transformer disconnect switch. See note B1e.
- d. Manufacturer shall provide a 1-inch conduit for secondary wiring from the voltage-transformer (VT) compartment to the meter compartment as shown. The conduit shall be located above the mounting platform as shown.
- e. The manufacturer shall provide a lifting eye above each voltage transformer for use with a pulley assembly to assist in installing and removing the transformers. Each eye shall support a minimum weight of 350 pounds.
- f. Except for heating elements and associated wiring specified and supplied by the manufacturer no other wiring or devices shall be installed in or routed through the voltage-transformer compartment.
- g. The manufacturer shall provide a voltage transformer mounting base as shown. See page 4-31 for drilling, spacing and clearance requirements.
- h. The manufacturer shall bus from the fuse holders to the voltage transformer (VT) compartment and provide landing terminals on each phase bus unit in the VT compartment for Department supplied conductors. The landing terminals shall consist of two 1/2-inch steel bolts. The bolts shall extend from 1-inch to 1-1/2-inches from the mounting surface and be spaced on 1-3/4-inch vertical centers. Each bolt shall be provided with a nut, flat washer and a split-ring washer. All parts shall be plated to prevent corrosion.

Note 1: Each phase bus landing terminals shall be located above the related voltage transformer primary spade. The manufacturer shall permanently identify the bus units with the phase designations in clearly visible block lettering.

Note 2: The Department will provide the conductors from the landing terminals to the voltage transformers and the BØ jumper between the transformers.
- i. The manufacturer shall provide and install two General Electric JVT-200 voltage transformers in the voltage-transformer compartment. See pages 4-30 and 4-31 for voltage transformer dimensions, spacing and mounting requirements.

METERING ENCLOSURE, 34500 VOLTS 3Ø 3-WIRE**B. VOLTAGE-TRANSFORMER AND FUSE COMPARTMENTS (Cont.)****3. VOLTAGE-TRANSFORMER FUSE COMPARTMENT**

- a. The width of the voltage transformer fuse compartment access opening shall permit unobstructed access to the fuses.
- b. The compartment doors shall be constructed as follows:
 - 1) The exterior doors shall be hinged, equipped with a full hand grasping, single-handle operated latching system and have locking provisions to accept a standard Department padlock having a 5/16-inch lock shaft and a 1-inch locking clearance.
 - 2) The fuse compartment doors shall be hinged, equipped with a full hand grasping handle on the side opposite the hinges and shall be lockable with a Kirk key interlock system so that the compartment cannot be entered without first opening the voltage-transformer disconnect switch. See note B1e.
 - 3) The exterior doors and the fuse compartment doors shall be equipped with durable devices to hold the doors open at 90-degrees or more. The devices shall be permanently attached to either the enclosure or the doors and may be automatic or manually operated but shall not require disassembly to operate.
- c. The fuse compartment shall be fully barriered to isolate the compartment from any energized bus or devices when the voltage transformer switch is in the open position. A full width and depth voltage-rated horizontal insulated barrier shall be provided to isolate the fuse compartment from the voltage transformer disconnect switch.
- d. The fuse compartment door shall be independent of the voltage-transformer disconnect switch cover.
- e. Manufacturers shall provide three fuse holders for mounting indoor current-limiting fuses for the protection of the voltage transformers. Each fuse holder shall be provided with two mounting clips having a separation of 17-1/4 inches (measured from clip centers) and accepting a fuse ferrule diameter of 1-3/5 inches.

Note: The Department will provide and install the fuses.
- f. The manufacturer shall bus from the voltage transformer disconnect switch to the line side of the fuse holders and from the load fuse holders to the voltage transformer compartment.

Note: The manufacturer shall permanently identify the bus units with the phase designations in clearly visible block lettering.
- g. The manufacturer shall provide a box on the inside of the fuse compartment door for storing three spare Cutler-Hammer 38CLPT-.5E fuses.
- h. Except for heating elements and associated wiring specified and supplied by the manufacturer no other wiring or devices shall be installed in or routed through the voltage-transformer compartment.

METERING ENCLOSURE, 34500 VOLTS 3Ø 3-WIRE

C. CURRENT-TRANSFORMER AND METERING COMPARTMENTS

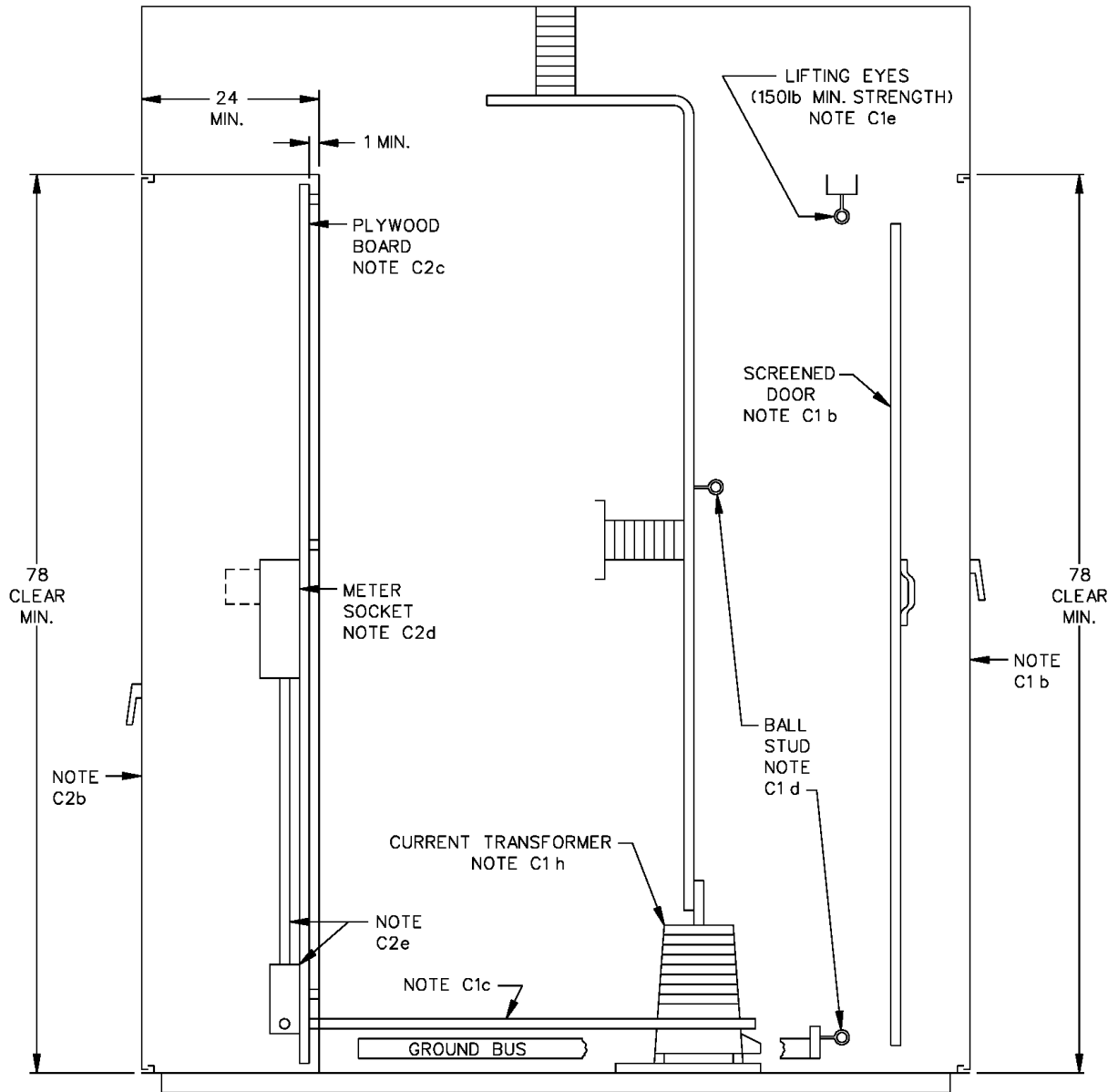

SIDE VIEW

FIGURE 1 CURRENT TRANSFORMER AND METER/TELECOM COMPARTMENTS

Note: Minimum bare bus clearances are 10" Ø to Ground, and 15" Ø-Ø in current transformer compartment

METERING ENCLOSURE, 34500 VOLTS 3Ø 3-WIRE

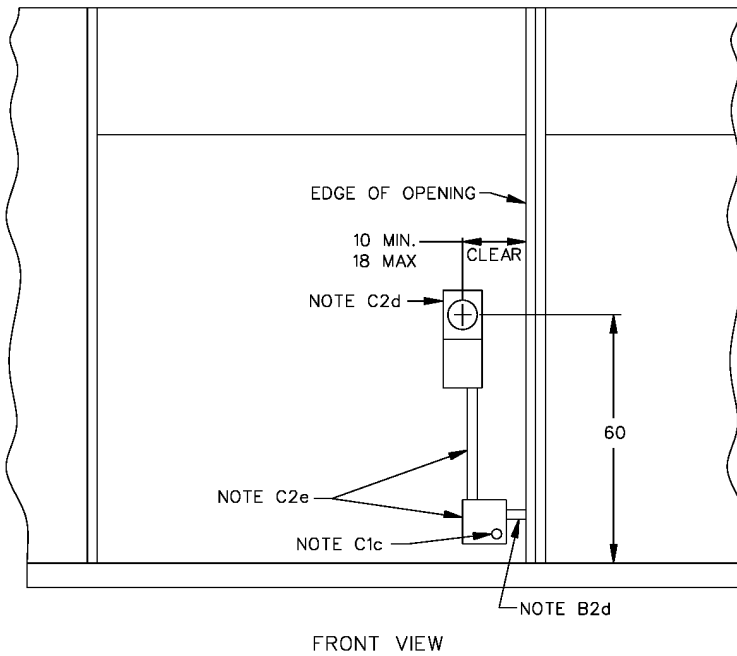

FIGURE 2 METERING AND TELECOMMUNICATION COMPARTMENT

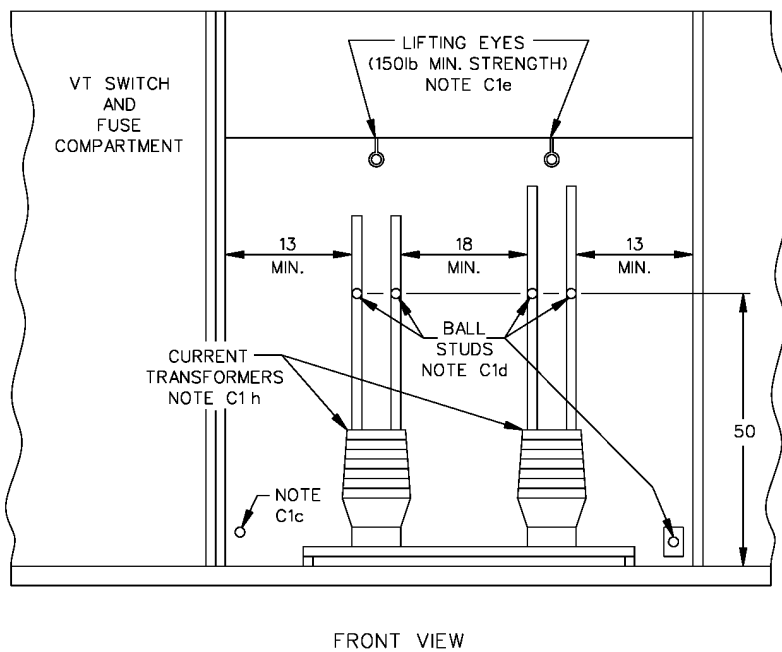

FIGURE 3 CURRENT-TRANSFORMER COMPARTMENT

METERING ENCLOSURE, 34500 VOLTS 3Ø 3-WIRE**C. CURRENT-TRANSFORMER AND METERING COMPARTMENTS (Cont.)****1. CURRENT-TRANSFORMER COMPARTMENT**

- a. The width of the current-transformer compartment access opening shall permit unobstructed access to the current transformers.
- b. The compartment doors shall be constructed as follows:
 - 1) The exterior doors shall be hinged, equipped with a full hand grasping, single-handle operated latching system on the side opposite the hinges, and shall have locking provisions to accept a standard Department padlock having a 5/16-inch lock shaft and a 1-inch locking clearance.
 - 2) The interior full height perforated or expanded metal screened door shall be hinged, secured with mechanical fasteners and have handles sized for full hand grasping.
 - 3) The exterior doors and interior screened doors shall be equipped with durable devices to hold the doors open at 90-degrees or more. The devices shall be permanently attached to either the enclosure or the doors and may be automatic or manually operated but shall not require disassembly to operate.
- c. Manufacturer shall provide a 1-inch conduit for secondary wiring from the current-transformer compartment to the meter socket panel.
- d. Manufacturer shall provide the following safety grounding provisions:
 - 1) Ball studs (1/2"-13 threads with insulating covers) for the attachment of safety grounds shall be provided on the line and load side of the current-transformer bus units. The studs shall be oriented toward the compartment access opening and located so that access to the studs is not across or through any phase busses or grounded parts.

Note: The bus shall be supported at the ball stud location to prevent movement during the safety grounding operation.
 - 2) The ground bus shall extend to either the front left or right sides of the compartment and shall be provided with a grounding terminal for use with the Department's safety ground. The terminal may be either a ground bail (1/2 x 15-inch minimum) or a ball stud (see note d1) and shall be identified with a label reading "SAFETY GROUNDING POINT FOR UTILITY USE ONLY".

Note: All ball studs or ground bails shall be positioned to allow the use of hot sticks to install and remove the utility grounding harness and shall not be obstructed or blocked by fixed panels.
- e. The manufacturer shall provide a support with a lifting eye above each current transformer position to assist in the installation and removal of the transformers. The eye shall support a minimum weight of 150 pounds.
- f. Except for heating elements and associated wiring specified and supplied by the manufacturer no other wiring or devices shall be installed in or routed through the current-transformer compartment.
- g. The manufacturer shall permanently identify the bus units with the phase designations in clearly visible block lettering.

METERING ENCLOSURE, 34500 VOLTS 3Ø 3-WIRE**1. CURRENT-TRANSFORMER COMPARTMENT (Cont.)**

- h. The manufacturer shall provide and install two General Electric JKW-7 current transformers on the AØ and CØ bus units in the current-transformer compartment. See pages 4-32 and 4-33 for current transformer dimensions, spacing and mounting requirements.

Note 1: The bus connections shall be on the back side of the current-transformer primary spades to permit easier removal of the transformers. Bus units shall be permanently identified with the phase designations in clearly visible block lettering.

Note 2: The manufacturer shall ground the transformers.

2. METERING COMPARTMENT

- a. The width of the compartment access opening shall permit unobstructed access to the metering and associated telecommunications equipment.
- b. The compartment doors shall be:
- 1) Hinged and equipped with a full hand grasping, single-handle operating system and shall have locking provisions to accept a standard Department padlock having a 5/16-inch lock shaft and a 1-inch locking clearance.
 - 2) Equipped with durable devices to hold the doors open at 90-degrees or more. The devices shall be permanently attached to either the enclosure or the doors and may be automatic or manually operated but shall not require disassembly to operate.
- c. The manufacturer shall provide and install 3/4-inch marine grade plywood on the back wall of the compartment for mounting metering and telecom equipment. The plywood shall be spaced 1-inch from the back wall and finished in a light color.
- d. The manufacturer shall provide a meter socket panel with provisions for test blocks complying with page 2-34, and jaw arrangements complying with page 2-5.
- e. The manufacturer shall provide and install 1-inch voltage-transformer and current-transformer conduits and a 12"W x 12"H x 6"D (minimum) junction box for meter wiring.

VOLTAGE TRANSFORMERS AND MOUNTING BASE DETAILS
34500 VOLTS 3Ø 3-WIRE

A. VOLTAGE TRANSFORMERS

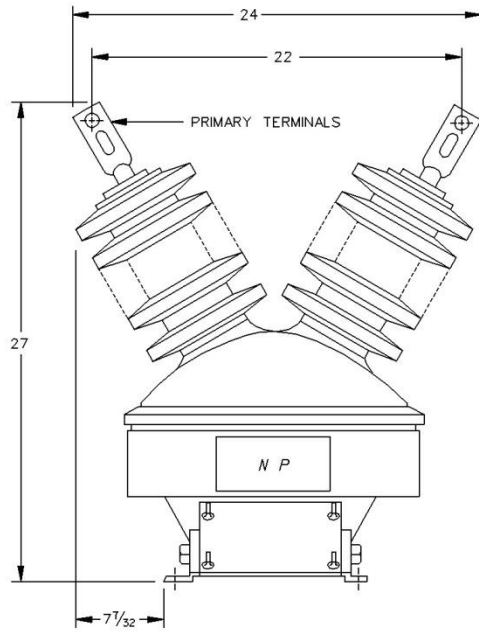

FIGURE 1 FRONT VIEW

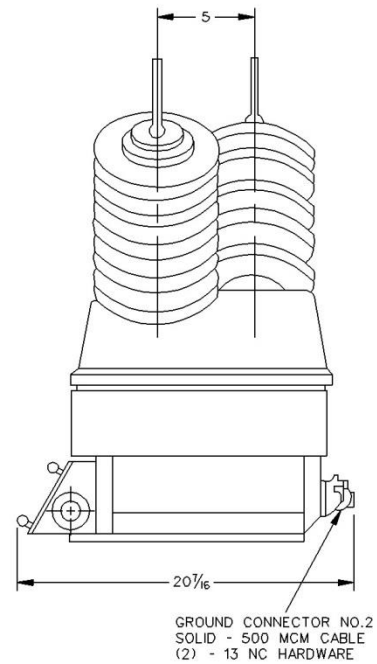

FIGURE 2 SIDE VIEW

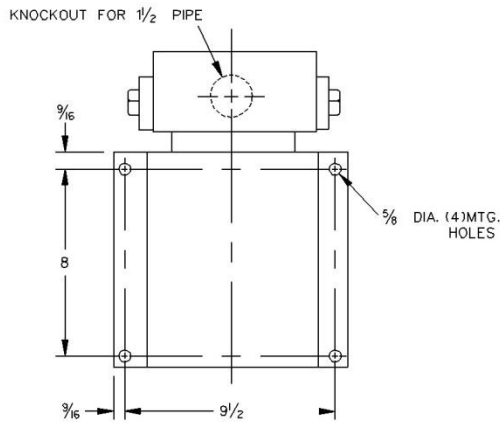

FIGURE 3 BOTTOM VIEW

VOLTAGE TRANSFORMERS AND MOUNTING BASE DETAILS
34500 VOLTS 3Ø 3-WIRE

A. VOLTAGE TRANSFORMERS (Cont.)

Manufacturer shall provide and install two General Electric JVT-200 two-bushing voltage transformers (G.E. catalog number 767X030001) as specified by the Department.

B. VOLTAGE TRANSFORMER MOUNTING BASE DETAIL

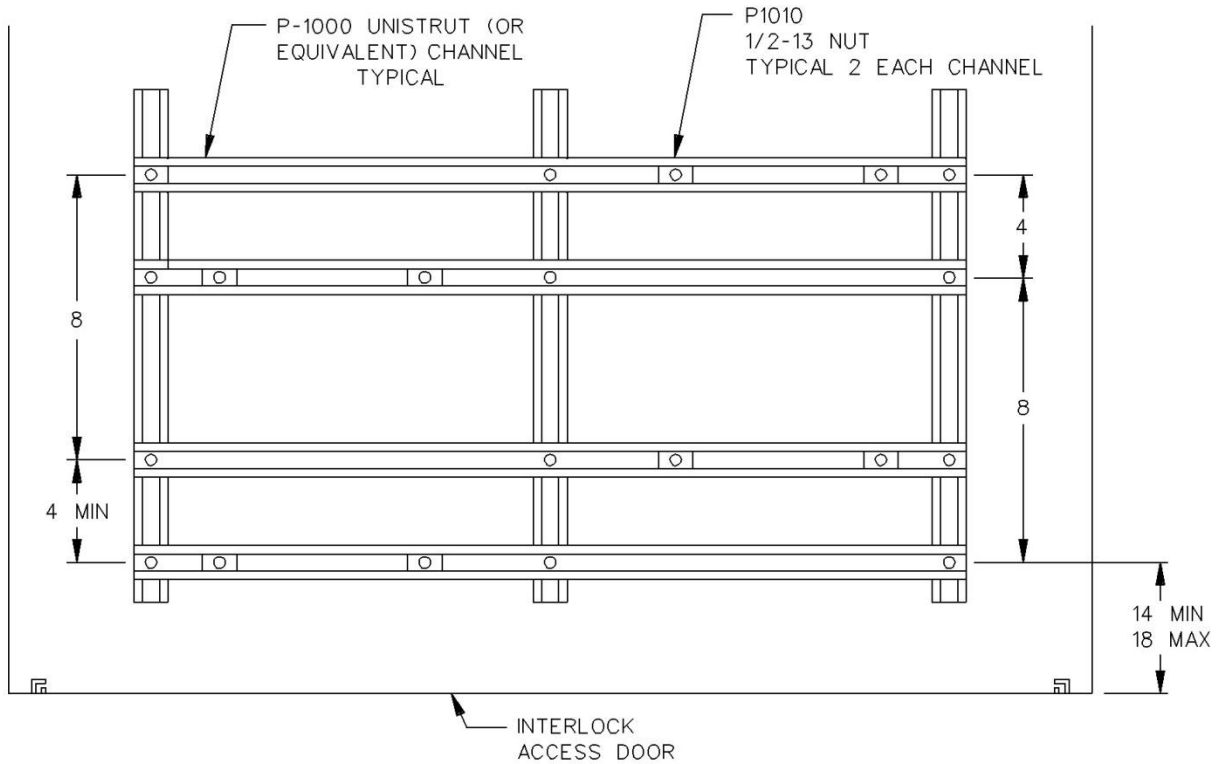

Note: The Unistrut spacing is based on the dimensions of the General Electric JVT-200 voltage transformer specified in these requirements.

CURRENT TRANSFORMERS AND MOUNTING BASE DETAILS
34500 VOLTS 3Ø 3-WIRE

A. CURRENT TRANSFORMERS

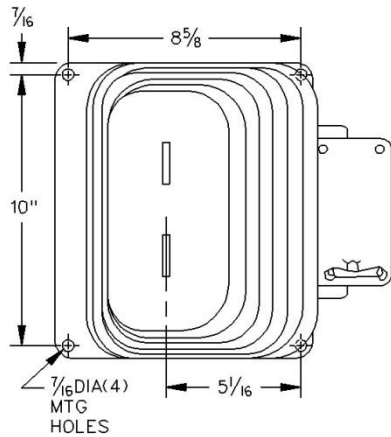

FIGURE 1 TOP VIEW

CATALOG NUMBER	PRIMARY AMPERES	"A"	"B"
757X050021	25 - 50	1-1/2	3/16
757X050022	50 - 100		
757X050023	75 - 150		
757X050024	100 - 200	2	1/4
757X050025	150 - 300		
757X050026	200 - 400		
757X050027	300 - 600		
757X050028	400 - 800		3/8

Ampere value to be specified by the Department

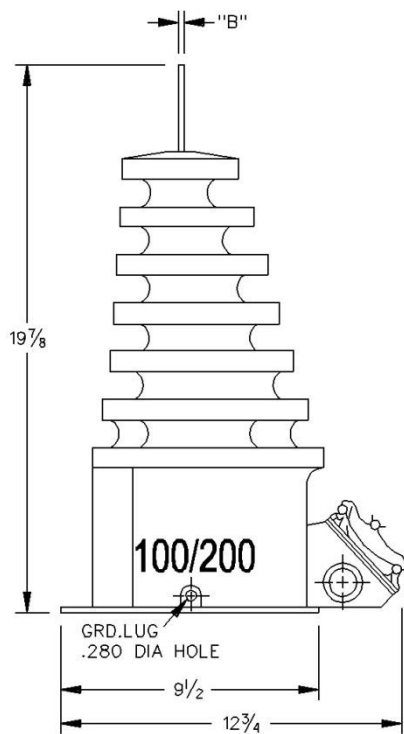

FIGURE 2 SIDE VIEW

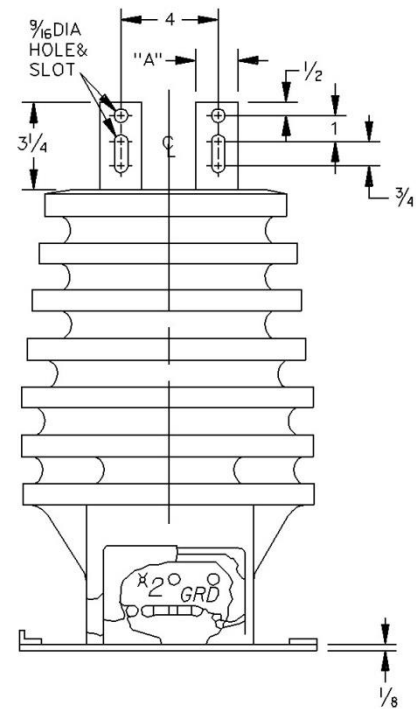
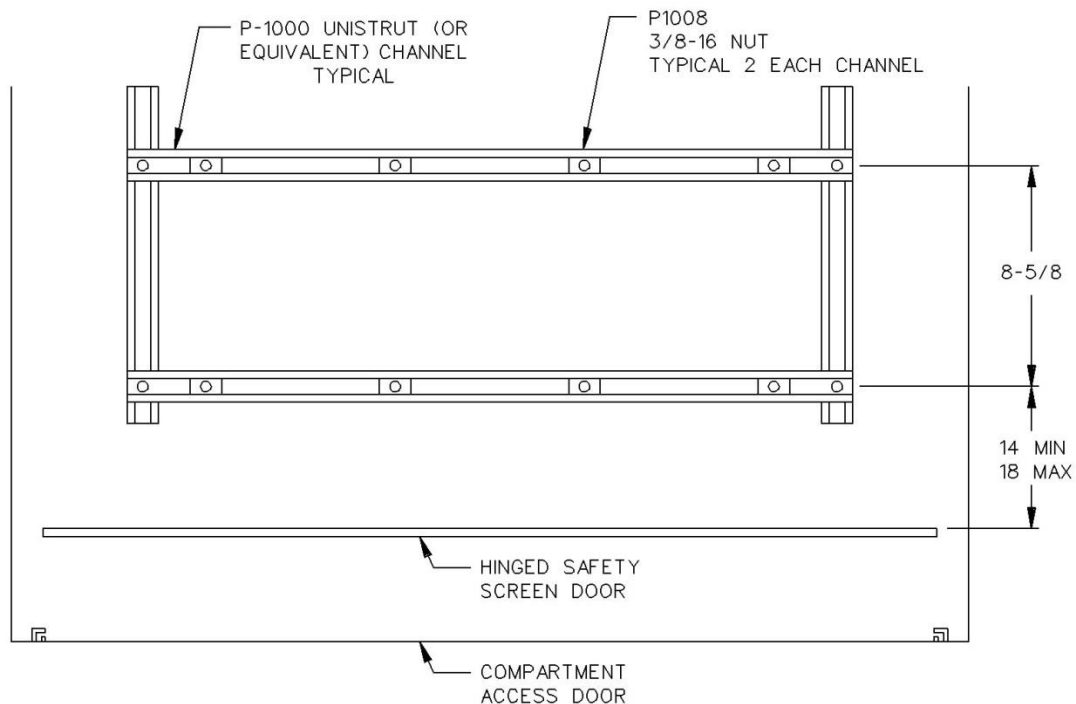

FIGURE 3 FRONT VIEW

CURRENT TRANSFORMERS AND MOUNTING BASE DETAILS
34500 VOLTS 3Ø 3-WIRE**A. CURRENT TRANSFORMERS (Cont.)**

Manufacturer shall provide and install two General Electric JKW-7 current transformers as specified by the Department.

Note: The catalog number of the current-transformers to be used in each application is to be determined by the Department's Customer Station Design engineer. For office locations and telephone numbers, see page 1-4.

B. CURRENT TRANSFORMER MOUNTING BASE DETAIL

Note: The Unistrut spacing is based on the dimensions of the General Electric JKW-7 current transformer specified in these requirements.

**UNDERGROUND SERVICE TERMINATING ENCLOSURE
34500 VOLTS 3Ø 3-WIRE**

Minimum bare bus clearances 10" Ø to Ground, 15" Ø-Ø

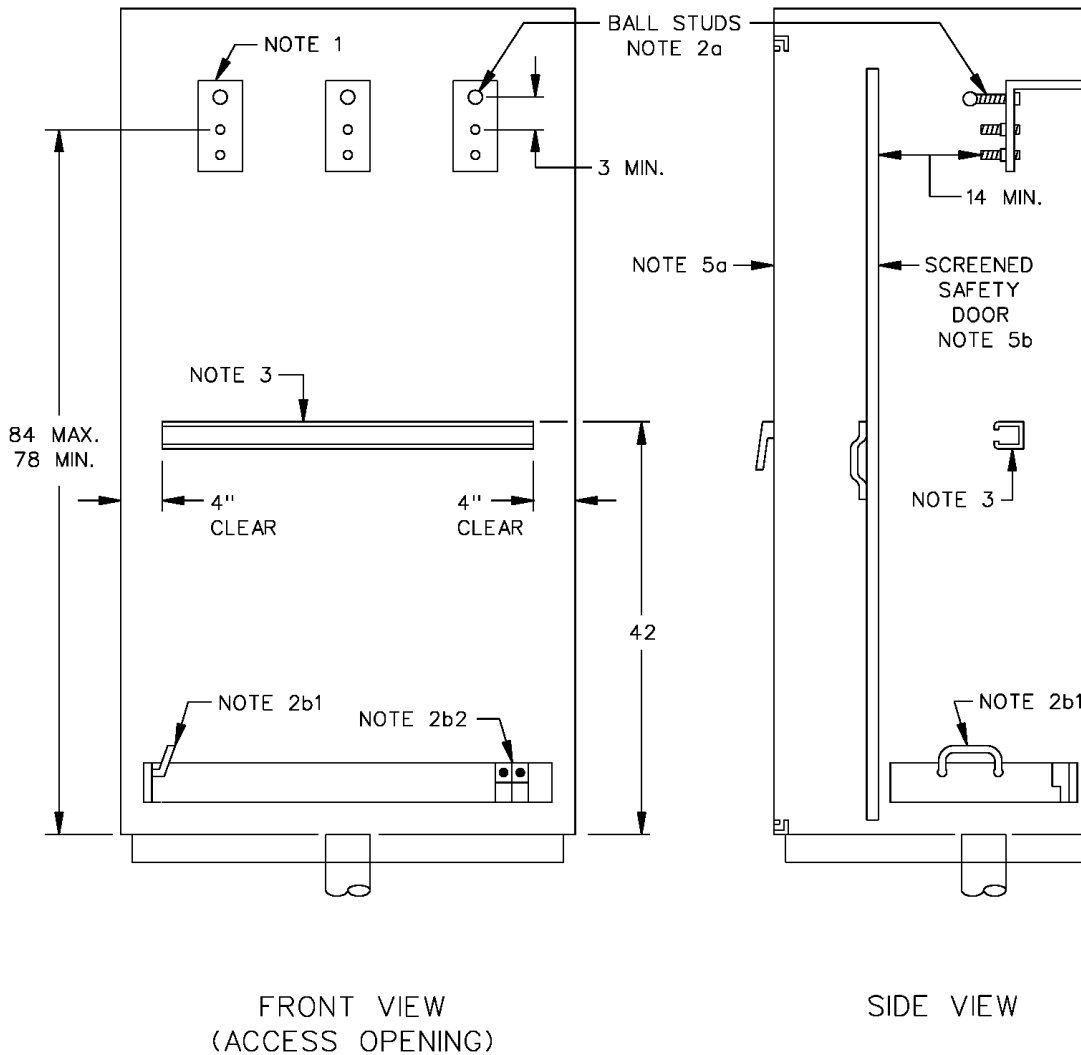

NOTES:

1. Cable terminating facilities shall be provided for the Department's service supply conductors as follows:
 - a. In general, one landing position shall be provided for each phase bus and shall consist of: two 1/2-inch steel bolts extending from 1-1/4-inches to 1-1/2-inches from the mounting surface and spaced on 1-3/4-inch vertical centers. If the Department specifies more than one set of landing positions for each phase bus, then positions shall be spaced on 4-inch centers.
 - b. Each bolt shall be furnished with a split-ring washer with a flat washer. Bolts shall be secured in place and all parts shall be plated to prevent corrosion.

Note: Secured in place means that the stud will not turn, back out or loosen in any manner when tightening or loosening the nuts.

UNDERGROUND SERVICE TERMINATING ENCLOSURE
34500 VOLTS 3Ø 3-WIRE

- c. The terminating facilities shall be centered relative to the compartment access opening and shall be permanently identified by the manufacturer with the phase designations in clearly visible block lettering.
2. Facilities for grounding shall be provided as follows:
 - a. For safety grounding, a ball stud (1/2"-13 threads with an insulating cover) for the attachment of safety grounds shall be provided on each phase termination bus. The ball stud shall be oriented to face the compartment access opening and positioned so that the hot stick and grounding hardware will not cross over phase bus units during the installation process.

Note: The ball studs shall not be less than 14" from the compartment hinged doors.
 - b. The ground bus shall extend to either the front left or right sides of the compartment and shall be provided with:
 - 1) A grounding terminal for use with the Department's safety ground. The terminal may be either a ground bail (1/2 x 15-inch minimum) or a ball stud as specified in note 2a above.

Note: All ball studs or ground bails shall be positioned to allow the use of hot sticks to install and remove the utility grounding harness and shall not be obstructed or blocked by fixed panels.
 - 2) Two aluminum-bodied mechanical lugs accepting a range of no. 6 through 250 KCMIL conductors. The lugs shall be identified with a label reading "GROUNDING POINT FOR UTILITY USE ONLY".
3. Provide one piece of Unistrut P-1000 (or equivalent) channel as shown as a support for the service supply conductors.
4. Except for heating elements and associated wiring specified and supplied by the manufacturer no other wiring or devices shall be installed in or routed through the current-transformer compartment.
5. The compartment doors shall be constructed as follows:
 - a. The exterior doors shall be hinged, equipped with a full hand grasping, single-handle operated latching system on the side opposite the hinges, and shall have locking provisions to accept a standard Department padlock having a 5/16-inch lock shaft and a 1-inch locking clearance.
 - b. The interior full height perforated or expanded metal screened door shall be hinged, secured with mechanical fasteners and have handles sized for full hand grasping.
 - c. The exterior doors and interior screened doors shall be equipped with durable devices to hold the doors open at 90-degrees or more. The devices shall be permanently attached to either the enclosure or the doors and may be automatic or manually operated but shall not require disassembly to operate.
 - d. The terminating facilities shall be centered relative to the compartment access opening and shall be permanently identified by the manufacturer with the phase designations in clearly visible block lettering.
 - e. The minimum clear compartment access opening width shall be 48-inches.
6. The Department's service supply conduits shall enter the bottom and be plum, level, square and reasonably centered on terminating facilities specified in note 1.

Date: 10-31-18

MEDIUM-VOLTAGE SWITCHGEAR, 2400-34500 VOLTS

EUSERC DWG. 420

ALL DIMENSIONS SHOWN ARE IN INCHES

BUSWAY SERVICE HEADS
2400-34500 VOLTS, 3Ø 3-WIRE

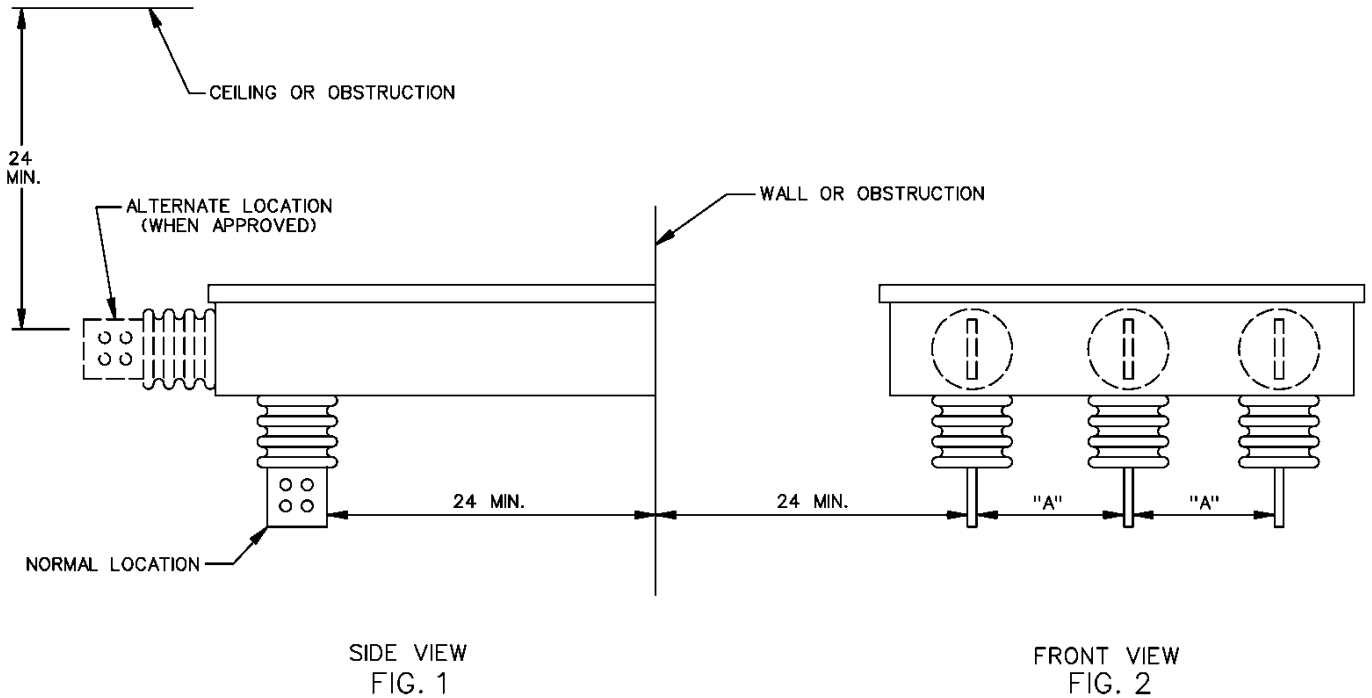

SERVICE VOLTAGE	"A"
2400-4800 (Volts)	8 MIN.
34500 (Volts)	24 MIN.

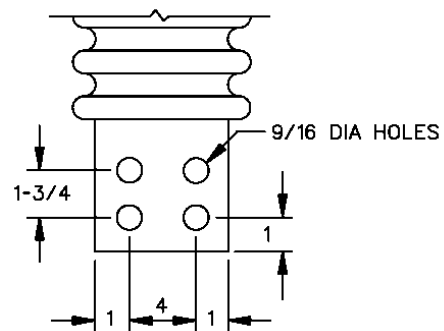

DRILLING DETAIL
(800 AMPERE TERMINAL SHOWN)

NOTES:

1. One terminal landing position is required for each 400 amperes of service ampacity or fraction thereof (i.e., one position for up to 400 amperes, two positions for 401 through 800 amperes, three positions for 801 amperes through 1200 amperes, etc.). Each landing position shall consist of two 9/16-inch holes spaced on 1-3/4-inch vertical centers. When multiple landing positions are required, the horizontal space between landing positions shall be 4 inches (minimum).
2. Terminations shall be spaced as shown in table above.
3. All bushings shall meet NEMA Standards for creep distance.

CONTENTS

	<u>PAGE</u>
A. Meter Locations	5-4
1. Residential Occupancies	5-4
2. Commercial and Industrial Occupancies	5-4
3. Added Metering Equipment	5-4
4. Unacceptable Metering Locations	5-5
5. Projections into Side Yards	5-6
B. Identifying Meters in Multi-meter Installations	5-6
C. Meter Rooms	5-7
1. Locations	5-7
2. Access	5-7
3. Doors	5-7
4. Locking Provisions	5-7
5. Identification	5-8
6. Equipment Arrangements	5-8
7. Foreign Equipment	5-9
8. Communication	5-10
9. Illumination	5-10
D. Meter Heights Working Space and Clearances, 0-600 Volts	5-11
1. Gas Meters	5-11
2. Meter Heights	5-12
3. Working Space and Clearances	5-13
4. Housekeeping Pads	5-14
5. Barrier Posts	5-15
E. Meter Heights Working Space and Clearances, 601-4800 Volts	5-16
1. Meter Heights	5-16
2. Working Space and Clearances	5-16
3. Housekeeping Pads	5-17
4. Barrier Posts	5-17
F. Meter Heights Working Space and Clearances, 34,500 Volts	5-18
1. Working Space and Clearances	5-18
2. Housekeeping Pads	5-18
3. Barrier Posts	5-18
G. Meter Cabinets	5-20
H. Temporary Underground Service Arrangements, Typical	5-22
I. Fiber-Optics Installations	5-24
1. General	5-24
2. Conduits	5-24
3. Terminating Arrangements	5-24

Date 05-02-24
:

DESIGN AND INSTALLATION GUIDE FOR METER AND SERVICE EQUIPMENT

CONTENTS (Cont.)

	<u>PAGE</u>
J. Hazardous (Explosive Atmosphere) Area Installations	5-26
1. General	5-26
2. Service Stations and Other Gasoline Dispensing Locations:	5-26
3. Methane Gas Hazard Areas	5-28
4. Typical Equipment Arrangements for Methane Locations	5-28
5. Alternative Fuel Dispensing and Storage Tank Locations	5-29
K. Electric Vehicle Installations	5-30
1. General	5-30
2. Signs and Labels	5-30
3. Metering	5-30
4. Typical Equipment Arrangements	5-31
5. References	5-32
L. Small Lot Subdivisions and Mobile Home Parks	5-32
1. General	5-32
2. Metering	5-32
3. References	5-32
M. Accessory Dwelling Units	5-33
1. General	5-33
2. Metering	5-33
3. References	5-33

**THIS PAGE LEFT
INTENTIONALLY BLANK**

A. METER LOCATIONS

1. RESIDENTIAL OCCUPANCIES

- a. For single-family residences, metering equipment shall be located to permit meters to be read or tested without entering any building on the premises. Wall-mounted metering equipment shall be mounted on, or recessed in, an exterior building wall.
- b. For multiple-occupancy buildings, metering equipment shall be:
 - (1) Located outdoors to permit meters to be read or tested without entering the building, or
Note: Wall-mounted metering equipment shall be mounted on, or recessed in, an exterior building wall.
 - (2) Located indoors in approved accessible public areas or meter rooms. See page 5-7 for meter room requirements.
 - (3) Grouped in a single location unless otherwise approved by the Department.
Note: For buildings over three floors, meters may be located and grouped on every third floor or increment thereof.

2. COMMERCIAL AND INDUSTRIAL OCCUPANCIES

Metering equipment shall be:

- a. Located so that the meters may be read or tested without entering the building, or
Note: Wall-mounted metering equipment shall be mounted on, or recessed in, an exterior building wall.
- b. Located indoors in approved accessible public areas or meter rooms. See page 5-7 for meter room requirements.
- c. Grouped in a single location unless otherwise approved by the department.
Note: For buildings over three floors, meters may be located and grouped on every third floor or increment thereof.

3. ADDED METERING EQUIPMENT

- a. Where there is a need to provide additional metering equipment to an existing installation, the customer shall contact the Department for an approved location.
- b. Additional equipment will normally be grouped with those meters already in service. Where in the Department's judgment this is not practical, an alternate metering location, including in the occupancy served, may be approved.
- c. In general, only one meter is allowed for each voltage class of service, except where otherwise permitted by the Department. Where the customer needs to increase the capacity of an existing facility, the capacity of the service and metering equipment shall be increased as opposed to the installation of additional meter and service equipment.

A. METER LOCATIONS (Cont.)**4. UNACCEPTABLE METER LOCATIONS**

- a. For reasons of safety, maintenance of equipment, and service reliability, meters shall not be permitted:
- (1) In any location with less than 3 feet clearance to any walk, alley, or driveway providing access to a commercial, industrial or multi-family residential premises.
 - (2) In any location with less than 12 inches clearance from face of meter panel to a single-family residential driveway, or where working space is within 3 feet of the swing of an automatic garage door.
 - (3) In any location where moisture, corrosive fumes, dust, excessive vibrations (as determined by the Department) and other conditions which may damage or interfere with the operation of the meter.
 - (4) In any hazardous location as determined by the Department.
 - (5) On any balcony, raised workspace or platform, mezzanine floor, roof, or any basement location.
Exception: Accessible by clear stairways of normal tread and rise including Code compliant fall prevention railing, where applicable. Doorways providing access shall be a minimum of 30 inches wide and 6 feet - 6" inches high.
 - (6) On any fence or retaining wall.
 - (7) Within any residential occupancy.
 - (8) Within any occupancy not served by the meter.
 - (9) Within any breezeway or carport except by permission of the Department.
 - (10) Directly over any stairway, ramp or steps.
 - (11) Directly over any plumbing fixture (See WORKING SPACE AND CLEARANCES, page 5-12).
 - (12) In any rest, bath, toilet, shower, or dressing room, or any room accessed through such areas.
 - (13) In any enclosed show window or one having a bulkhead or raised platform.
 - (14) In any attic or place not in general use.
 - (15) In any projection room.
 - (16) Behind any switchboard having bare and exposed live parts, unless the meter is located at least 5 feet from such parts.
 - (17) In any substation or transformer vault, unless such meter is in an enclosure which is effectively screened from the high-voltage compartment.
 - (18) In any elevator shaft or hatchway, or in any room containing elevator equipment, unless all such equipment is guarded and meters are located outside the guarded area.
 - (19) In any location protected by alarm systems. In any location with security gates or doors, guard dogs, or other security measures unless approved by the Department.

A. METER LOCATIONS (Cont.)**4. UNACCEPTABLE METER LOCATIONS (Cont.)**

(20) On any mobile home or trailer.

Exceptions (underground service only):

(a) Temporary mobile school buildings.

(b) Residential mobile homes, which are:

1) Located on individual private lots (not mobile home parks)

2) A minimum of 10 feet wide.

3) Installed on a permanent foundation system which is defined by Title 25 as:

“A foundation system is an assembly of materials constructed below, or partly below grade, not intended to be removed from its installation site, which is designed to support the mobile home and engineered to resist the imposition of external natural forces.” A State HUD form 433(A) must be submitted to the Department as proof of compliance with these requirements.

Note: This requirement does not apply to modular/factory built homes. These types of structures will be served the same as any framed (stick built) home.

(21) In any fenced portion of a freeway that requires the meter to be read or tested from within the fenced area.

(22) Where a door or gate swing encroaches into working space or causes entrapment.

(23) Any area that requires access by a ladder or ship ladder.

(24) Any surface that is subject to excessive movement or vibration as determined by the Department.

(25) In any other location judged unacceptable to the Department.

b. Where metering equipment is not located in a Department approved location, or is no longer accessible because of additions or changes to the premises, the customer shall provide, at the customer's cost, a new and Department approved service location.

5. PROJECTIONS INTO SIDE YARDS

Permitting agencies may limit the projection of service and metering equipment, or enclosures used to house such equipment, into a side or front yard. The customer must consult with the permitting agency before planning any proposed projections.

B. IDENTIFYING METERS IN MULTI-METER INSTALLATIONS

Where a meter does not serve an entire building or premises, the meter socket and its related meter switch shall be clearly and permanently marked by the customer to indicate the occupancy address or load served. The following are examples of acceptable permanent markings:

1. Identification plates secured by screws, rivets, or an equivalent secure adhesive.
2. Commercially available decals that use adhesive suitable to the application.
3. Weatherproof paint applied by stencil or legible lettering.

C. METER ROOMS

A meter room is a weatherproof, illuminated room provided by the customer and used to enclose electric service and metering equipment. Meter rooms shall be constructed to meet the following requirements:

1. LOCATIONS

When service is provided from underground electric service supply lines, meter rooms shall be located on a first floor, basement, or garage level having permanent vehicle access.

Note: Some meter locations may require additional provisions to facilitate remote metering, see **COMMUNICATION** page 5-10.

2. ACCESS

- a. Meter rooms located on a first floor or basement level shall have access from a door located on the building exterior wall opening directly into the room or, when approved by the Department, from a door opening directly into the room from a public area or hallway. Where a second access door is provided, the door shall not exit into any occupancy.
- b. Meter rooms located on garage levels shall have doors opening directly to the garage or parking area.
- c. Meter rooms located in basement areas of buildings shall have stairs of normal tread and rise.
- d. Meter room egress shall not be through areas or rooms containing foreign equipment, see **FOREIGN EQUIPMENT** page 5-9.

3. DOORS

- a. Entrance to the meter room shall be through a doorway not less than 30 inches wide and 6 feet-6 inches high.
- b. Doors shall be designed to open outward from the room and be equipped with listed panic hardware. If this is not practical in the Department's judgment, doors may be permitted to open into the room provided the doors are:
 - (1) Equipped with devices to hold the door in the open position.
 - (2) Located so the doors will not open into the meters or obstruct any required working space.
 - (3) Permitted by the Los Angeles Department of Building and Safety or other authority having jurisdiction (AHJ).

Note: ROLL-UP DOORS AND TOP-HINGED DOORS ARE NOT ACCEPTABLE.

4. LOCKING PROVISIONS

- a. When the meter room is to be locked, the customer shall install a lock-box in a permanent location on the meter room door, or in a readily accessible location adjacent to the meter room door. The Department will supply the lock-box.
- b. The customer will provide a key for the meter room door lock to be housed in the lock-box before the electric service will be energized. The key will be used for access by the Department.

5. IDENTIFICATION

- a. Each meter room door shall be provided with a permanent sign reading "ELECTRIC METER ROOM".

C METER ROOMS (Cont.)

- b. Where more than one meter room or location is provided, the sign shall identify each location by number (i.e., "1 of 2" and "2 of 2") and shall include a map of the building showing the other meter locations and areas controlled by each location.
- c. The sign shall be metal or plastic with engraved or machine printed letters, or electro-photo plating, in a contrasting color to the sign and shall be attached with screws, pop-rivets or epoxy.

6. EQUIPMENT ARRANGEMENTS

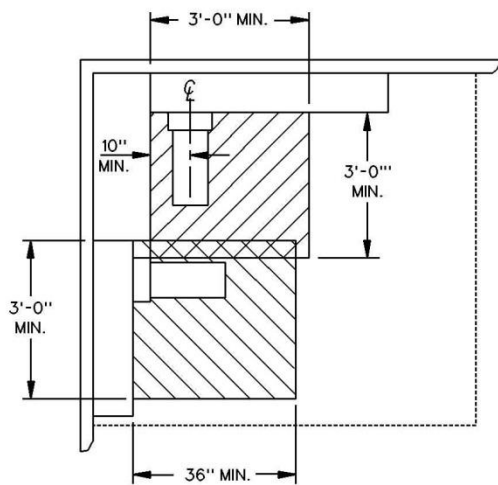

PLAN VIEW
FIGURE 1

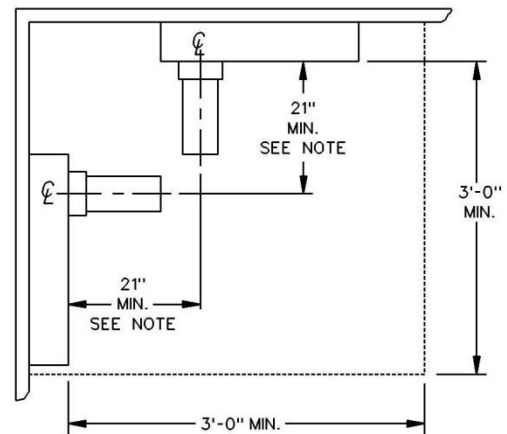

PLAN VIEW
FIGURE 2

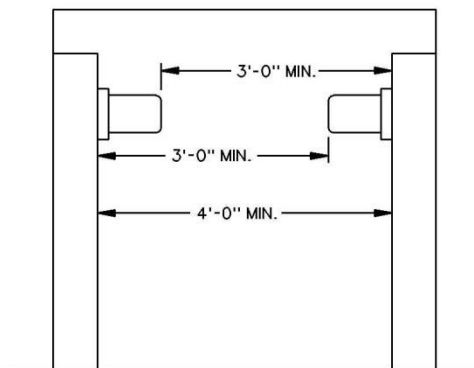

FINAL GRADE
SIDE VIEW
FIGURE 3

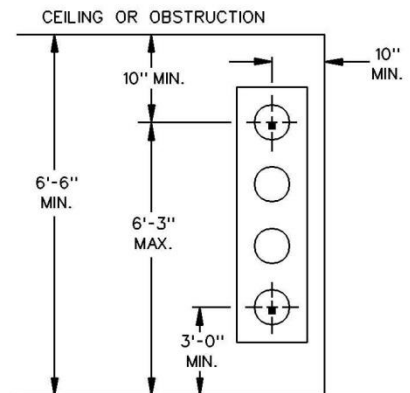

PLAN VIEW
FIGURE 4

Note: Dimension (Figure 2) may be reduced to from 21" to 17" if the socket on the side serves a residential occupancy. All dimensions shown are for 0-600V and shall be increased in accordance with the working clearance requirements for higher voltages.

C. METER ROOMS (Cont.)

- a. A level standing and working space shall be provided in front of service and metering equipment. The space shall:
 - (1) Be the width of the service and metering equipment but not less than 3 feet.
 - (2) Extend a minimum of 3 feet from the face of the service and metering equipment to any obstruction. When meter panels are installed facing each other, the working space between the panels shall be a minimum of 4 feet to allow adequate working space with meters installed. See page 5-8 figure 3.
 - (3) Extend vertically from the standing and working surface to the top of the service and metering equipment but not less than 6 feet-6 inches.
- b. The preferred location for underground terminating enclosures (i.e., pull boxes and pull sections) is on the wall opposite the meter room access door. Where this is not practical, the enclosure may be installed, with Department approval, on a wall perpendicular to the access door. The terminating enclosure shall not be installed on the same wall as the access door except as permitted by the Department for installations with small supply conductors or short cable runs.

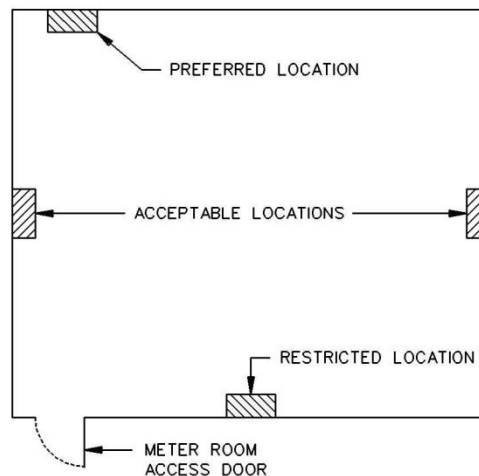

UNDERGROUND TERMINATING ENCLOSURE LOCATIONS

FIGURE 1

7. FOREIGN EQUIPMENT

- a. Cable television, telephone, and other communication installed in the meter room shall not obstruct working and access clearances to the electric service and metering equipment.
- b. The meter room shall not be used for storage or warehousing purposes.
- c. The following equipment shall not be permitted within the meter room:

C. METER ROOMS (Cont.)

- (1) Gas equipment – including piping.
- (2) Water heaters or boilers.
- (3) Security alarm systems connected to the access doors that operate when entry is made to the meter room.
- (4) Wet or gel filled batteries utilizing hydrogen absorption systems.
Exception: Sealed batteries used in fire alarm control boxes are permitted.
- (5) Lithium-ion and lithium-polymer batteries.
- (6) Equipment containing SF6 (Sulfur Hexafluoride) gas.
- (7) Any other equipment or facilities judged to be unacceptable by the Department.

NOTE: For additional requirements, see **METER LOCATIONS** on page 5-4.

8. COMMUNICATION

Where a reliable communication signal is not available, such as when a meter room is located in a basement or below grade garage level, for remote metering purposes, as appropriate for the location, and at the Department's discretion, the customer shall provide one of the following:

- a. A dedicated 120 volt, 15 ampere power circuit with a NEMA 5-15R receptacle and sufficient space on a wall near the meters for a Department installed 'signal booster' or 'data repeater' device measuring approximately 12 inches long x 12 inches wide x 6 inches high, or;
- b. A customer installed and maintained analog telephone line for each meter. All telephone lines shall be terminated in a junction box located no more than 36 inches from the customer's metering equipment, or;
- c. Sufficient space on a wall near each meter for a Department installed antenna measuring approximately 3 feet long.

The Department will visit the customer's site to make a determination as to which of the above methods are appropriate based on the meter room location, quantity of meters, status of the communication network in the meter room and around the building, and proximity of the meters to windows or open spaces.

9. ILLUMINATION

The lights shall be controlled by on-and-off switches. Timers and motion detectors are not allowed to control the meter room lighting.

D. METER HEIGHTS, WORKING SPACE AND CLEARANCES, 0-600 VOLTS

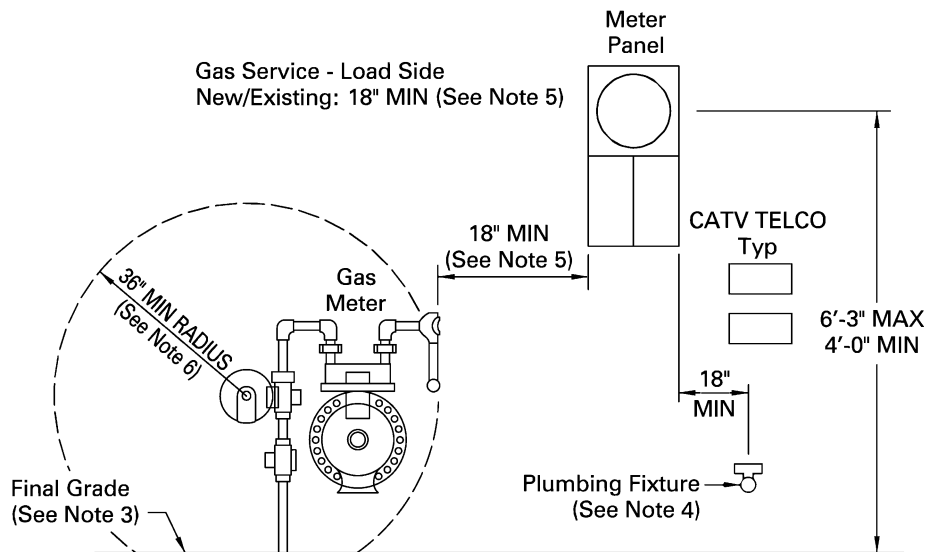
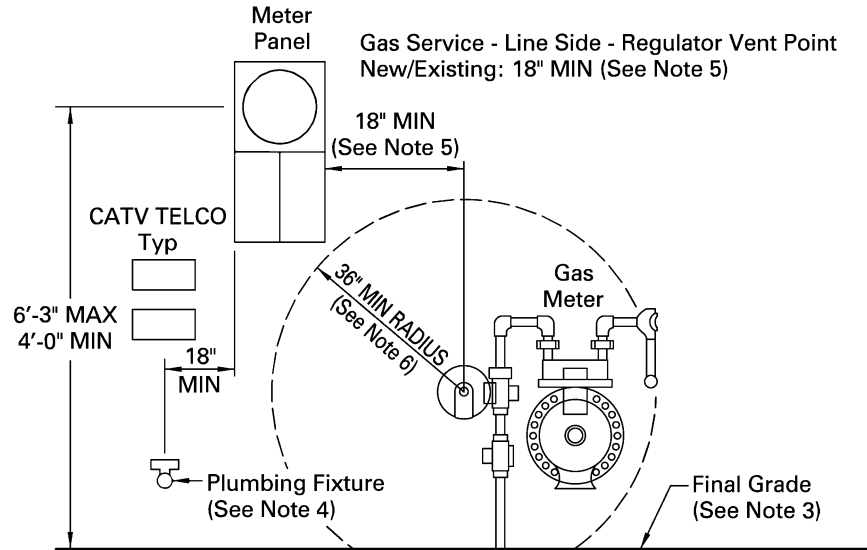

NOTES:

1. Size and dimensions of panels will vary. Drawings are not to scale.
2. This drawing pertains to both overhead and underground electric service applications.
3. Maintain a 3-foot (minimum) clear, level and unobstructed workspace centered on but not less than the width of the electric service and metering equipment.
4. Plumbing fixtures that extend more than 6 inches out from wall surface must be located a minimum of 18 inches from the outside edge of the electric service and metering equipment.
5. Dimensioned from the outside edge of the electric service and metering equipment. For all new construction, upgrades and replacements. This dimension may not be reduced.
6. Clear radial dimension centered on the regulator vent point. For all new construction, upgrades and replacements. This dimension may not be reduced.
7. For gas appliances, see page 5-14.

D. METER HEIGHTS, WORKING SPACE AND CLEARANCES, 0-600 VOLTS (Cont.)

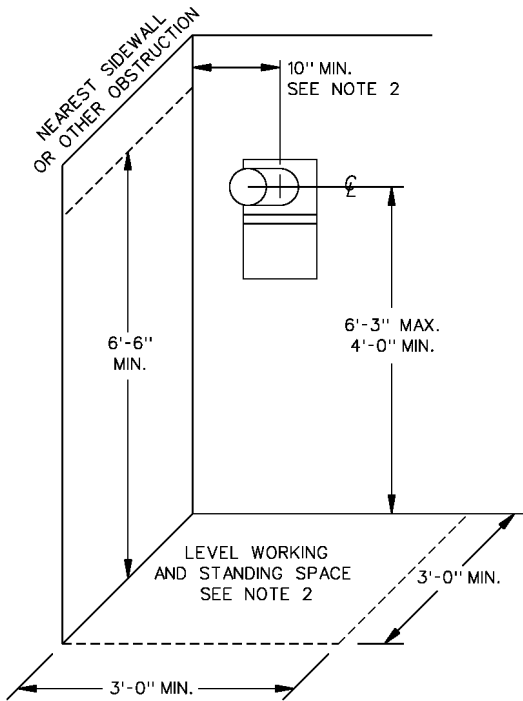

WALL-MOUNTED SURFACE OR SEMI-FLUSH METER INSTALLATION

FIGURE 1

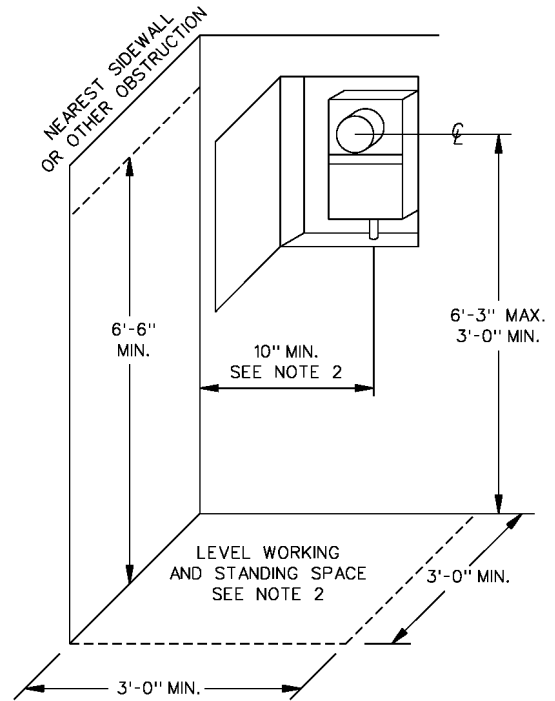

WALL-MOUNTED ENCLOSED METER INSTALLATION
SEE PAGE 5-20 FOR ENCLOSURE CLEARANCES

FIGURE 2

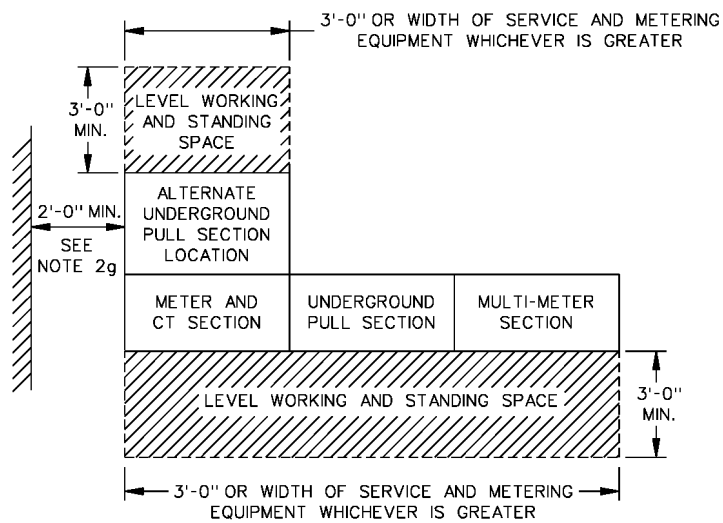

SWITCHBOARD METERING INSTALLATION

FIGURE 3

D. METER HEIGHTS, WORKING SPACE AND CLEARANCES, 0-600 VOLTS (Cont.)

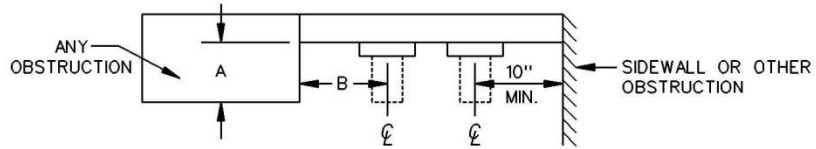

"A"	"B"
0"	3-3/4" min.
Greater than 0" to 2"	4-1/4" min.
Greater than 2" to 11"	6-1/4" min.
Greater than 11"	10" min.

FIGURE 4

NOTES:

1. METER HEIGHTS

The meter height shall not exceed 6 feet-3 inches or be less than 4 feet above the standing and working surface as measured from the centerline of the meter socket.

Exception 1: For meters enclosed in a cabinet (Page 5-20) or located in a meter room (Page 5-7), the minimum meter height may be reduced to 3 feet.

Exception 2: For multi-meter panels located on an exterior wall, the minimum meter height may be reduced to 3 feet as long as at least one meter socket is located at not less than 4 feet.

Exception 3: For exposed meter panels (no meter cover) installed on telecom cabinets in public property, the minimum meter height may be reduced to 3 feet.

2. WORKING SPACE AND CLEARANCES

a. A level standing and working space shall be provided in front of service and metering equipment (i.e., meter panels and underground terminating enclosures). The working space:

- (1) Width shall be 3 feet (minimum) but not less than the width of the service and metering equipment. The space does not need to be centered beneath the meter socket.
- (2) Depth shall extend 3 feet (minimum) from the face of the service and metering equipment or from the face of the cabinet used to enclose such equipment. If there are no obstructions from the top of the cabinet to the standing surface (i.e., shelves or ledges) when the cabinet doors are open, the 3 foot measurement may be taken from the face of the service and metering equipment.

Note: Consult the permitting agency regarding additional space requirements when the voltage-to-ground exceeds 150 volts.

- (3) Height shall extend 6 feet-6 inches (minimum) from the standing surface but not less than the top of the service and metering equipment.

b. The level standing and working space shall be located entirely on the property served.

D. METER HEIGHTS, WORKING SPACE AND CLEARANCES, 0-600 VOLTS (Cont.)

- c. The horizontal clearance from the centerline of the meter to the nearest side wall or other obstruction shall be a minimum of 10 inches.
- d. Pull boxes, main service disconnect enclosures and other devices shall be located so they will not interfere with meter setting or testing. See figure 4.
- e. Water plumbing fixtures that extend more than 6 inches out from the face of the meter panel must be located a minimum of 18 inches measured horizontally from the outside edge of the meter panel.
- f. Gas appliances and associated plumbing must be located a minimum of 3 feet measured horizontally from the edge of the appliance or associated plumbing fixture to the edge of the meter panel.
- g. Clearances shall be increased where necessary to permit hinged door or meter panels to be fully opened.
- h. Where equipment or access to equipment is located on different sides of a switchboard, a walkway at least 24 inches in width shall be provided around at least one end of the switchboard.
- i. Hinged doors shall open a minimum of 90-degrees and when in the open position shall provide a minimum 24 inch access/exit route.

3. HOUSEKEEPING PADS

- a. Where **indoor (NEMA-1) service and metering equipment** is installed within a building on an elevated portion of the floor (housekeeping pad), the pad shall be flush with, or extend a minimum of 3 feet in front of, the service and metering equipment. See Figures 1 and 2.
- b. Where **outdoor (NEMA-3R) raintight service and metering equipment** is installed on a housekeeping pad, the pad shall extend a minimum of 3 feet from the face of the raintight enclosure. See Figure 3.
- c. Housekeeping pads shall extend the width of the underground terminating enclosure and metering sections but not less than 3 feet.

INDOOR SWITCHBOARD ON
FLUSH HOUSEKEEPING PAD

FIGURE 1

INDOOR SWITCHBOARD ON
EXTENDED HOUSEKEEPING PAD

FIGURE 2

DOG HOUSE OR NEMA 3R ENCLOSURE
ON EXTENDED HOUSEKEEPING PAD

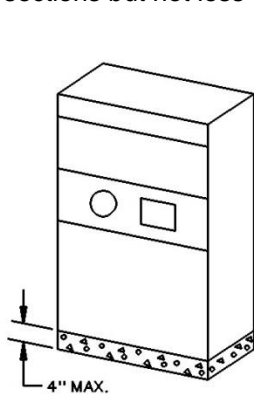
FIGURE 3

D. METER HEIGHTS, WORKING SPACE AND CLEARANCES, 0-600 VOLTS (Cont.)

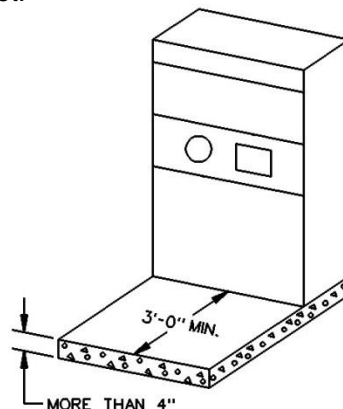
4. BARRIER POSTS

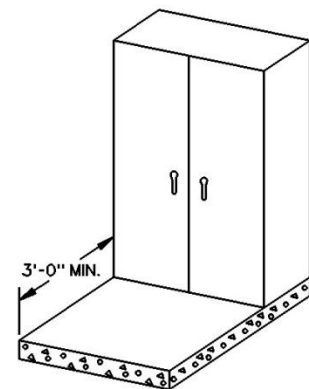
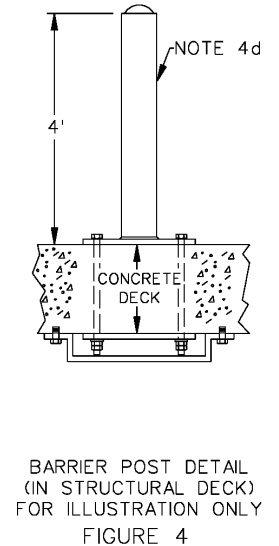
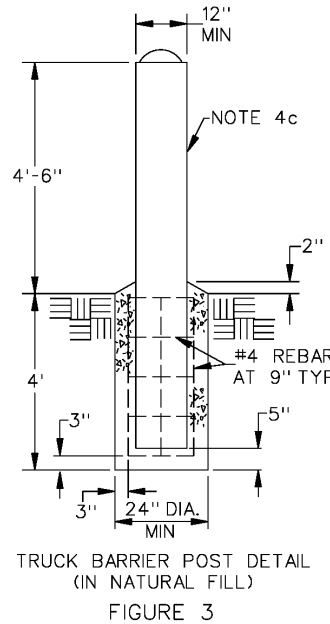
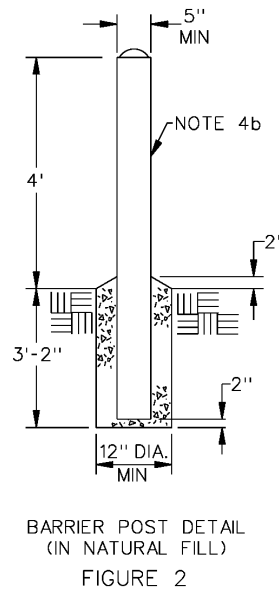
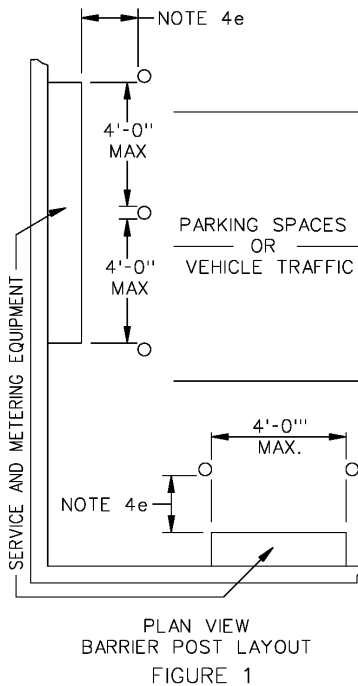

- a. Barrier posts, or other Department approved protection, shall be furnished and installed by the customer when the required working space is exposed to vehicular traffic, hazardous conditions or when otherwise specified by the Department.

Note: Barrier posts are not required for single-family residential services unless, in the Department's judgment, there are unusual conditions requiring barrier posts.

- b. Barrier posts shall be constructed from galvanized pipe (5-inch minimum diameter) installed in a concrete foundation. The post shall be concrete filled with a concrete cap as shown (figure 2).
- c. In areas exposed to truck traffic, barrier posts shall be constructed from galvanized pipe (12-inch minimum diameter) installed in a #4 rebar reinforced concrete foundation using mix 560-C-3250. The post shall be concrete filled with a concrete cap as shown (figure 3).
- d. Barrier posts installed in a structural concrete deck (figure 4), shall be designed by the customer's civil or structural engineer to comply with the latest California building code for vehicle barrier systems. A copy of the stamped drawings with calculations shall be submitted to the Department for record only. For more information, refer to the Department's standard drawing **UA721-09 "General Barrier Post Guidelines for Concrete Deck Applications"**.
- e. Barrier posts shall be located so that hinged access doors may open fully and with a maximum spacing between posts of 4 feet to prevent vehicle contact. The closest surface of the post shall not be less than 3 feet from the face of the service and metering equipment or from the face of the cabinet used to enclose such equipment (figure 1).

Note: Consult the permitting agency when the voltage-to-ground exceeds 150 volts.

E. METER HEIGHTS, WORKING SPACE AND CLEARANCES, 601-4800 VOLTS

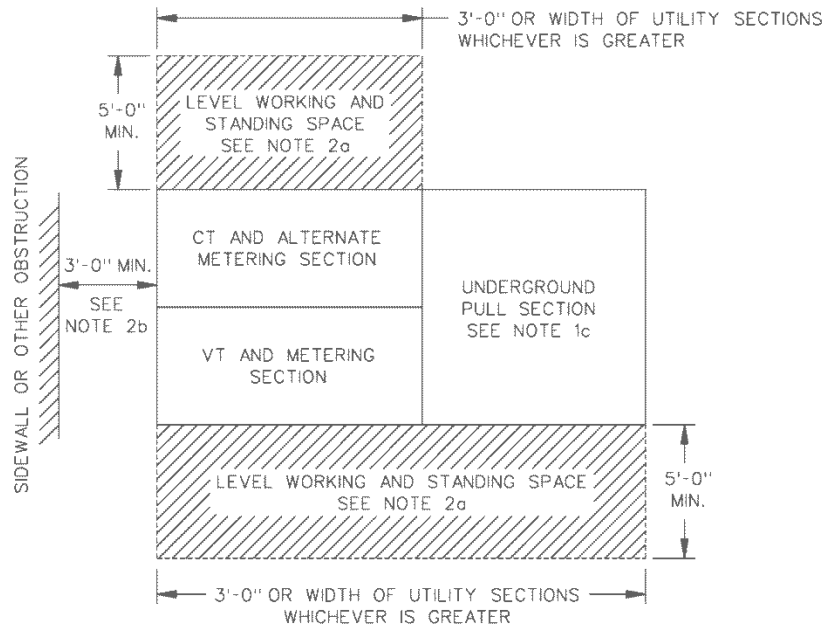

FIGURE 1

1. METER HEIGHTS

The maximum meter height shall not exceed 6 feet-3 inches or be less than 4 feet as measured from the centerline of the meter socket to the standing and working surface.

Exception: Where a remote meter panel is enclosed in a raintight cabinet or located in a meter room, the minimum meter height may be reduced to 3 feet.

2. WORKING SPACE AND CLEARANCES

- a. Switchgear sections shall be provided with a minimum of 5 feet of clear, level, unobstructed working and standing space in the front of each utility section containing meters and associated equipment (i.e., test switches, current transformers, voltage transformers and fuses) or service supply cable terminating facilities. The width of the working and standing space of each utility section shall be as wide as the section but not less than 3 feet.

Exception: For switchgear sections located on both sides of the working space, the minimum Depth of clear, level, unobstructed working and standing space provided shall be increased to 6 feet.

Note: "In front of" means in the direction of access to live parts in the compartment.

- b. Since the switchgear design requires access to both the front and rear of the switchgear, a walkway of not less than 3 feet in width shall be provided around one end of the switchgear.
- c. The pull section access opening (See Front View on page 4-18) may be oriented to face either the current-transformer (CT) side, voltage transformer (VT) side or end of the switchgear.

E. METER HEIGHTS, WORKING SPACE AND CLEARANCES, 601-4800 VOLTS (Cont.)

- d. Hinged doors shall open a minimum of 90-degrees and when in the open position shall provide a minimum 24 inch access/exit route.

3. HOUSEKEEPING PADS

- a. When indoor, non-raintight (NEMA-1) switchgear is installed on an elevated portion of the floor, or housekeeping pad, the pad shall be either flush with, or extend a minimum of 5 feet in front of, the utility sections. If the pad is flush with the front of the switchgear sections, the maximum meter height of 6 feet-3 inches shall not be exceeded.
- b. When outdoor raintight (NEMA-3R) switchgear is installed on a housekeeping pad, the pad shall extend a minimum of five feet in front of the utility sections as measured from the face of the switchgear enclosure.

4. BARRIER POSTS

- a. Barrier posts, or other Department approved protection, shall be furnished and installed by the customer when the required working space is exposed to vehicular traffic, hazardous conditions or when otherwise specified by the Department.
- b. Barrier posts shall be constructed from galvanized pipe (5-inch minimum diameter) installed in a concrete foundation. The post shall be concrete filled with a concrete cap as shown on page 5-15.
- c. Barrier posts shall be located so that hinged access doors may open fully and with a maximum spacing between posts of 4 feet to prevent vehicle contact. The closest surface of the post shall not be less than 5 feet from the face of the service and metering equipment or from the face of the cabinet used to enclose such equipment as shown on page 5-15 (figure 1).

F. METER HEIGHTS, WORKING SPACE AND CLEARANCES, 34,500 VOLTS

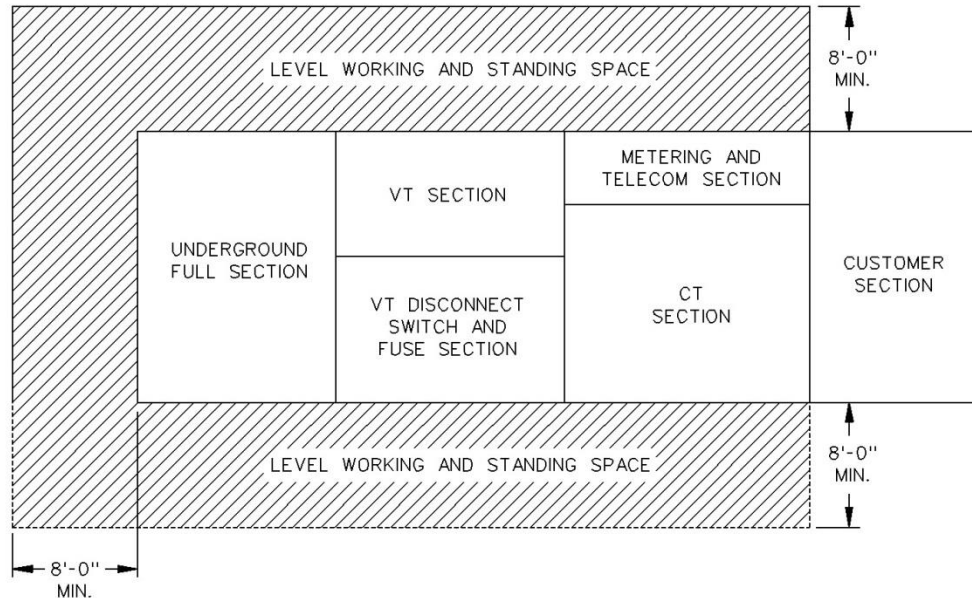

TYPICAL SWITCHGEAR ARRANGEMENT

1. WORKING SPACE AND CLEARANCES

- a. Switchgear sections shall be provided with a minimum of 8 feet of clear, level, unobstructed working and standing space in the front of each of the utility sections (i.e., sections enclosing meters, current transformers, voltage transformers, fuses or service supply cable terminating facilities). The width of the working and standing space of each utility section shall be as wide as the section but not less than 3 feet.

Exception: For switchgear sections located on both sides of the working space, the minimum depth of clear, level, unobstructed working and standing space provided shall be increased to 10 feet.

Note: "In front of" means in the direction of access to live parts in the compartment.

- b. Since the switchgear design requires access to both the front and rear of the switchgear, a walkway of not less than 8 feet in width shall be provided around one end of the switchgear.
- c. The pull section access opening (See Front View on page 4-34) may be oriented to face either the current-transformer (CT) side, voltage transformer (VT) side or end of the switchgear.

2. HOUSEKEEPING PADS

The housekeeping pad shall extend a minimum of eight feet in front of the utility sections as measured from the face of the switchgear enclosure.

F. METER HEIGHTS, WORKING SPACE AND CLEARANCES, 34,500 VOLTS (Cont.)**3. BARRIER POSTS**

- a. Barrier posts, or other Department approved protection, shall be furnished and installed by the customer when the required working space is exposed to vehicular traffic, hazardous conditions or when otherwise specified by the Department. The closest surface of the post shall not be less than 8 feet from the face of the metering enclosure as shown on page 5-15 (figure 1).
- b. Barrier posts shall be constructed from galvanized pipe (5-inch minimum diameter) installed in a concrete foundation. The post shall be concrete filled with a concrete cap as shown on page 5-15.
- c. Barrier posts shall be located so that hinged access doors may open fully and with a maximum spacing between posts of 4 feet to prevent vehicle contact.

G. METER CABINETS (Cont.)

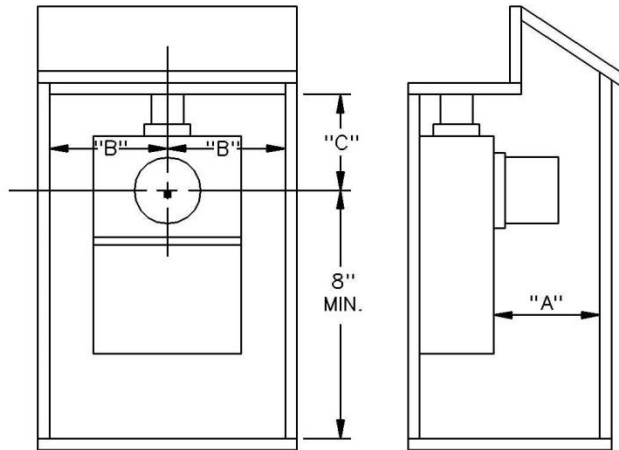

PANEL TYPE	"A" (inches)		"B" (inches)	"C" (inches)
	MIN.	MAX.	MIN.	MIN.
RESIDENTIAL	7	10	10	10
COMMERCIAL	11	18	10	10

CABINETS FOR SINGLE-METER INSTALLATIONS

FIGURE 2

1. A meter cabinet or enclosure will be required whenever:
 - a. Indoor (NEMA 1) service and metering equipment is installed in outdoor locations.
 - b. Meters are installed in any school location that is accessible to student traffic.
 - c. Meters are installed in any location where, in the Department’s judgment, moisture, fumes, dust, or similar deteriorating agents will damage or interfere with the operation of the meter.
2. Meter cabinet doors may be either side-hinged or sliding. Hinged doors shall open a minimum of 90-degrees and when in the open position shall provide a minimum 24 inch access/exit route. Sliding doors shall be individually tracked; be top roller mounted and slide easily.

Note: ROLL-UP DOORS AND TOP-HINGED DOORS ARE NOT ACCEPTABLE.

3. Door jams and vertical posts installed in the cabinet opening shall provide the required clearances for meters and terminating enclosures.
4. When the meter cabinet is to be locked, the customer shall install either a double locking mechanism or a lock-box. The lock box shall be in a permanent location on the meter cabinet door, on the meter cabinet, or in a readily accessible location adjacent to the meter cabinet. The Department will supply the lock-box.

Note: For lock-box installations, the customer shall provide a key for the meter cabinet door lock to be housed in the lock-box before the electric service will be energized. The key will be used for access by the Department.

G. METER CABINETS (Cont.)

- 5. The minimum clearance may be reduced to 7 inches for residential meter sockets.
- 6. A level standing and working space shall extend:
 - (1) 3 feet minimum as measured from the face of the cabinet to the property line or any obstruction.

Note: If there are no obstructions from the top of the cabinet to the standing surface (i.e., shelves or ledges) when the cabinet doors are open, the 3 foot measurement may be taken from the face of the service and metering equipment.

- (2) Vertically to a height of 6 feet-6 inches as measured from the standing and working surface.

H. TYPICAL TEMPORARY UNDERGROUND SERVICE ARRANGEMENTS
(200 AMPERES MAXIMUM, 0-600 VOLTS)

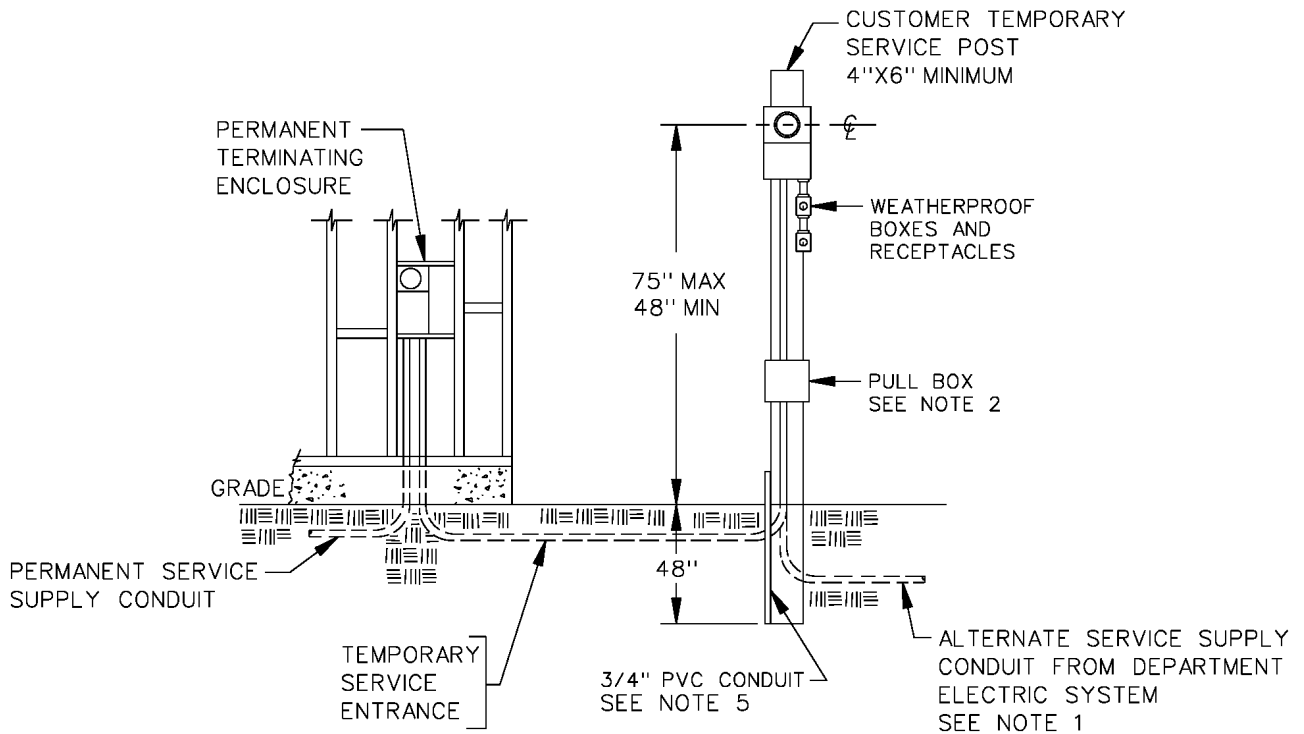

TEMPORARY METER POST ARRANGEMENT

- 1. For underground installations, temporary service arrangements may be supplied from either the underground terminating enclosure (pull box or pull section) for the permanent service or directly from the Department’s electric system. When supplied from the permanent terminating enclosure, the contractor shall provide and install the service entrance conductors from the terminating enclosure to the temporary service pole.

Note: Meter panels provided for temporary power shall not be installed on building interior or exterior walls to avoid conflicts for meter reading access or construction operations.

H. TYPICAL TEMPORARY UNDERGROUND SERVICE ARRANGEMENTS (Cont.)

2. When the customer's temporary service is supplied directly from the Department's electric system, the customer shall install a pull box enclosure for termination of the Department's service supply conductors. The customer shall provide the conduit and wiring from the pull box to the meter socket panel.
3. A residential meter socket may be used for 100-ampere single-phase services. A safety socket box is required for 200-ampere single-phase services and for all three-phase services. Service equipment and receptacles must be weatherproof, rated for the load to be served and adequately bonded and grounded.
4. "Piggy-back" meter socket panels that plug into the customer's permanent meter socket to provide temporary service are not permitted.
5. Contractor shall install a 5ft long by 3/4 inch diameter Schedule 40 PVC conduit flush with the bottom of the CTS pole, permanently capped at the bottom, a removable cap at the top, and securely strapped to the pole with adequate spacing to allow for easy removal of the top cap for depth inspection.
6. References:
 - a. For working space and clearance requirements, see page 5-12.
 - b. For safety-socket meter panel details, see pages 2-24 and 2-26.
 - c. For engineering offices and phone numbers, see page 1-4.
 - d. For pull box requirements, see page 2-13.

I. FIBER-OPTICS INSTALLATIONS

1. GENERAL

Customers shall provide fiber-optics facilities, as specified by the Department, on premises supplied underground with:

- a. Commercial or industrial structures of 50 or more tenants.
- b. Commercial or industrial structures of 100,000 square feet or larger – excluding warehouses, parking facilities, and other predominately storage oriented facilities.
- c. Residential multi-tenant complexes of 50 or more units.

Note: The Department may require customers to provide fiber-optics facilities for other installations where, in the Department's judgment, automated meter reading, demand side management or other automated distribution functions may be used.

2. CONDUITS

- a. A conduit for enclosing fiber-optics conductors shall be generally installed as follows:
 - (1) **For premises with transformer structures** (i.e., transformer pads or vaults), a conduit shall be installed from the property line to the transformer structure(s) and from the transformer structure(s) to each metering location – where a building or structure has more than one metering location, a fiber-optics conduit is required at only one of the locations.
 - (2) **For premises with indoor transformer rooms**, a fiber-optics conduit shall be installed from the property line to the transformer room. A fiber-optics conduit may also be required from the transformer room to the metering location if the metering location is either (a) in another building or (b) in a location sufficiently remote from the transformer room so that future installation of the conduit, in the Department's judgment, is impractical.
- b. The conduit shall run in the same trench and be the same size as the primary or service conduit installed in the trench but not less than 4-inches trade size.
- c. Bending and spacing requirements shall be the same as the electric conduits in the same trench.

3. TERMINATING ARRANGEMENTS

- a. **For service and metering equipment located on outside building walls or within meter rooms**, terminating arrangements for fiber-optics conduits shall be provided as follows:
 - (1) The fiber-optics conduit shall terminate in the bottom center of a pull box, provided by the customer, measuring a minimum of 12" H x 12" W x 6" D.
 - (2) The pull box shall be mounted a minimum of 4 feet above the floor or standing surface as measured from the bottom of the box and no other equipment or obstructions shall be installed above the box.
 - (3) The pull box shall not intrude into the clear working space required in front of the underground terminating enclosure, metering panels or any other installed equipment.

I. FIBER-OPTICS INSTALLATIONS (Cont.)

- (4) A label shall be provided on the pull box cover, by the customer, reading "DEPARTMENT OF WATER AND POWER, FIBER-OPTICS". The label shall be constructed of either metal or plastic with engraved or machine printed letters (1/2 inch minimum) and shall be attached with screws, pop-rivets or epoxy.

- b. **For service and metering equipment provided in freestanding, weatherproof (NEMA-3R) enclosures remote from buildings or structures,** fiber-optics terminating arrangements shall be provided as follows:
 - (1) The customer shall provide a location for a future fiber-optics pedestal, to be installed by the Department, on the concrete pad adjacent to the weatherproof enclosure. The location shall accommodate a pedestal with base measuring 24" x 24".

 - (2) The pedestal location shall not intrude into the clear working space required in front of the underground terminating section, metering section, or any other sections with removable or hinged access panels.

 - (3) The fiber-optics conduit shall terminate in the space provided for the pedestal base and not less than 2 inches above the concrete pad and not less than 12-inches from the edge of the concrete pad or 9 inches from the switchboard enclosure. The conduit shall be capped and provided with a pull tape.

J. HAZARDOUS (EXPLOSIVE ATMOSPHERE) AREA INSTALLATIONS

1. GENERAL

- a. Metering equipment and terminating enclosures (i.e., pull boxes and pull sections) used for the connection of the Department's service supply conductors shall not be installed in locations that may have ignitable levels of flammable vapors, gases, liquids or fibers present as defined in Sections 500 (division classifications) and 505 (zone classifications) of the latest editions of the City of Los Angeles Electric Code, California Electric Code or the National Electric Code.

Note: The Department often terminates its supply conductors while energized and meters are always tested under energized conditions. Both of these procedures can cause arcing conditions leading to catastrophic results if performed in an explosive atmosphere.

- b. The Department utilizes procedures (including duct sealing compounds) in some service installations to inhibit the intrusion of explosive gases and vapors that may be present in the Department's underground distribution system into the customer's underground terminating enclosures. However, the Department's procedures do not meet the explosive gas mitigation methods approved by the City of Los Angeles Department of Building and Safety (DBS) or other permitting agencies and cannot be used to meet the mitigation requirements of the customer's building permit.
- c. It is the customer's responsibility to identify hazardous locations to the Department's service planning office and to design the service and metering facilities to avoid conflict with the Department's Electric Service Requirements and the applicable City, State or National Electric Codes.
- d. Meter and service facilities constructed in explosive atmosphere hazardous areas shall be relocated by the customer at the customer's expense to conform to the Department's requirements as well as the applicable permitting agency's requirements.

2. SERVICE STATIONS AND OTHER GASOLINE DISPENSING LOCATIONS

Service supply (lateral) conduits shall not be installed through any class 1, division 1 or 2 area. All service cable terminating and metering facilities shall be located outside of the hazardous areas. The areas classified as hazardous locations (see figure 1) are identified as follows:

- a. The area within an 18 inch radius measured from the outside of the gasoline dispensers and the area within 18 inches of the ground surface and within a 20 foot radius of the gasoline dispensers as measured from the outside of the dispensers.
- b. The area within 18 inches of the ground surface and within a 5-foot radius from a tight fill connection and a 10-foot radius from a loose fill connection as measured from each fill pipe provided for underground gasoline storage tanks.
- c. The area within 18 inches of the ground surface and within a 5 foot radius measured from each ventilation opening provided for underground gasoline storage tanks.
- d. The area below the surface of the hazardous areas identified above (a through c) is considered to be Class 1, Division 1 (most restrictive). No limit is given for how far the hazardous area extends below the surface.

J. HAZARDOUS (EXPLOSIVE ATMOSPHERE) AREA INSTALLATIONS (Cont.)

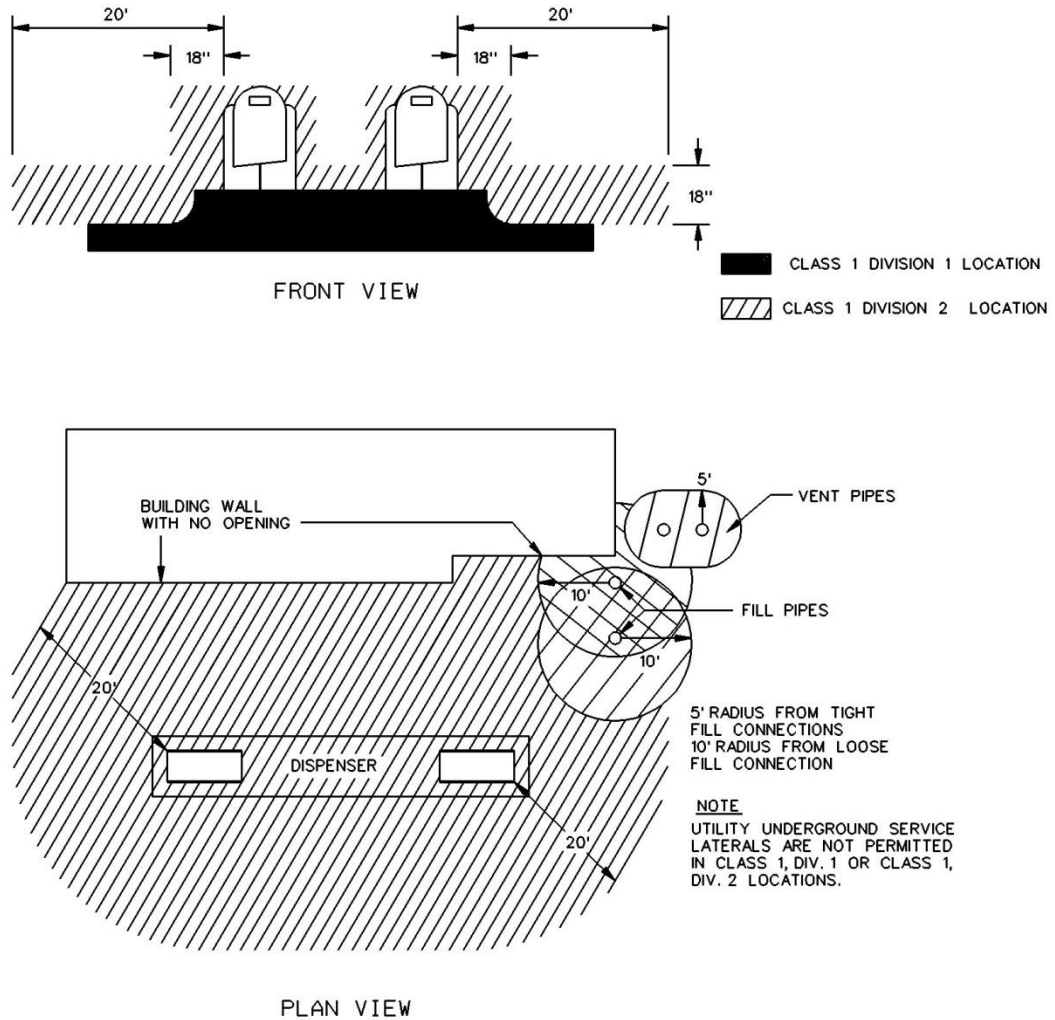

FIGURE 1

J. HAZARDOUS (EXPLOSIVE ATMOSPHERE) AREA INSTALLATIONS (Cont.)**3. METHANE GAS HAZARD AREAS**

- a. Methane is a naturally occurring volatile gas that may be present in the soil in varying concentrations throughout the Los Angeles Basin. While a proposed development may be in a known Methane Zone or Methane Buffer Zone, any lot or development site in the Los Angeles area may have methane present and require mitigation measures as required by the City of Los Angeles Methane Ordinance.
- b. It is the customer's responsibility to determine the methane status of any proposed project and to advise the Department of that status at the time the customer's plans are submitted for review since the presence of methane will directly affect the service design requirements specified by the Department's service planning offices.

Note: Site information for the methane status on some lots may be found on the Los Angeles Department of Building and Safety (LADBS) website (www.ladbs.org) under zoning information.

4. TYPICAL EQUIPMENT ARRANGEMENTS FOR METHANE LOCATIONS

- a. While the Department utilizes mitigation procedures (including conduit sealing compounds) in some service installations to inhibit the possible intrusion of explosive gases and vapors that may be present in the Department's underground distribution system into the customer's underground service terminating enclosures, these procedures do not meet the approved explosive gas mitigation methods approved by the LADBS or other permitting agencies and cannot be used to meet the mitigation requirements of the customer's building permit.
- b. Hazardous gas mitigation procedures, when required under the customer's permit, shall be applied between the service supply terminating enclosure and the associated metering equipment. Under no circumstances shall customer-owned hardware used to mitigate hazardous gas be installed on or in service supply conduits or underground service terminating enclosures.
- c. Service termination enclosure locations:
 - (1) The Department's underground service terminating enclosure (i.e., pull box or pull section) shall not be installed within any building or building wall in any methane area, methane boundary area, or other location that requires the installation of explosive gas seals or devices for compliance with the City of Los Angeles Methane Ordinance.

Note: If the methane status of a site changes after the service supply terminating enclosure is installed within a building or building wall and requires the installation of explosive gas seals or devices, the terminating enclosure shall be relocated outside of the building or building wall and the required gas mitigation devices shall be provided between the terminating enclosure and the associated metering sections.
 - (2) Refer to the Department's soil gas standard H-242 for acceptable distribution and service equipment arrangements, gas levels and sealing requirements.
- d. Underground service termination enclosures that are located on the outside wall outside of buildings and not recessed in the wall or are padmounted may be installed as follows:
 - (1) For padmounted terminating enclosures installed away from buildings, a "double" switchboard pull section may be installed to supply metering sections located within the buildings. The utility termination section shall be built in compliance with ESR page 3-44, Figure 1. The customer load wireway section may be sized to meet the customer's wiring requirements.

J. HAZARDOUS (EXPLOSIVE ATMOSPHERE) AREA INSTALLATIONS (Cont.)

(2) For padmounted terminating enclosures located on the exterior wall of a building, a single standard pull section (ESR page 3-44) or pull box (ESR page 2-15 or 2-16) may be used with the service entrance conductors exiting the enclosure above any terminating facilities provided in the enclosure.

Note: Terminating enclosures and their associated supply conduits shall not be recessed within the building wall.

(3) Refer to the Department’s soil gas standard H-242 for acceptable distribution and service equipment arrangements, gas levels and sealing requirements.

e. For installations where methane mitigation standards require that the terminating enclosure be supplied with vents or louver vented doors, such provisions shall be tamper resistant incorporating an inner barrier designed to prevent intrusion and have a minimum NEMA rating of 3R for outdoor use.

5. ALTERNATIVE FUEL DISPENSING AND STORAGE TANK LOCATIONS

Service supply (lateral) conduits shall not be installed through any class 1, division 1 or 2 area. All service cable terminating and metering facilities shall be located outside of the hazardous areas. Minimum clearances for areas classified as hazardous locations for alternate fuel dispensing and storage tanks are as follows:

Fuel Type	A/G Tank	U/G Tank	Dispenser	Fill Pipes	Generators (self-contained)	Piping	Pumps	Vents
CNG	5ft	10ft	5ft	5ft	10ft	20ft	20ft	5ft-R
Diesel	5ft	10ft	5ft	5ft	10ft	20ft	20ft	5ft-R
Jet (JP-4)	50ft	50ft	50ft	50ft	50ft	50ft	50ft	50ft R
LNG	10ft	10ft	10ft	10ft	10ft	20ft	20ft	5ft R
LOX	50ft	50ft	50ft	50ft	50ft	50ft	50ft	50ft R
LH2	25ft	N/A	10ft	25ft	25ft	25ft	25ft	25ft R
H2	15ft	N/A	5ft	15ft	15ft	15ft	15ft	15ft R
Propane	20ft	20 - 50ft*	20 - 25ft**	10ft	10ft	20ft	20ft	5ft R

* For tanks over 2,000 gallons

** Over 500 lbs. stored

TYPICAL RESIDENTIAL ELECTRIC VEHICLE METER AND EQUIPMENT ARRANGEMENTS

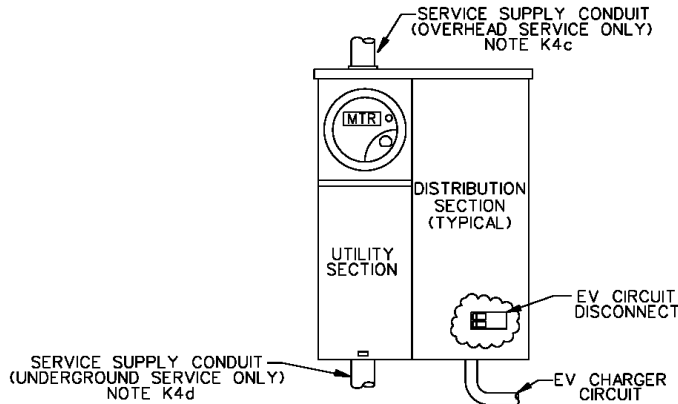

FIGURE 1

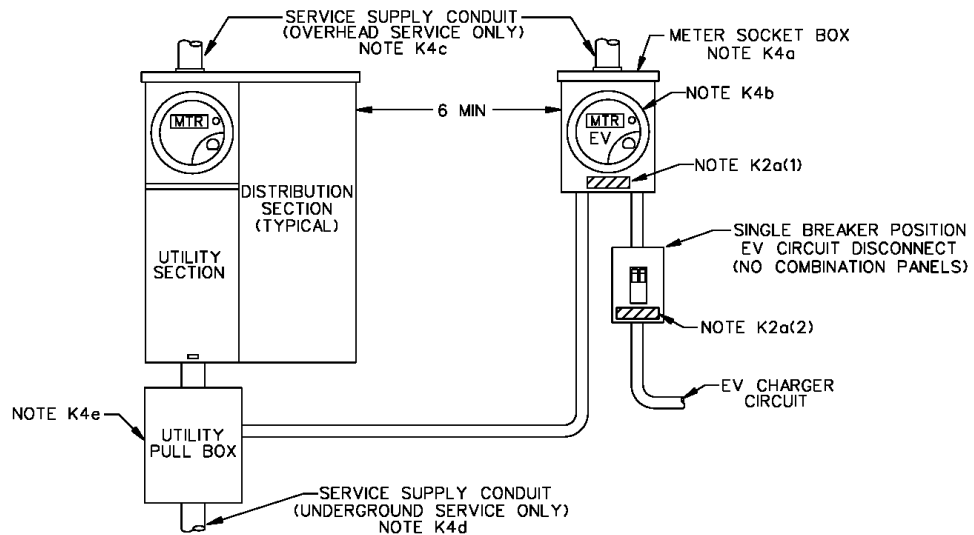

FIGURE 2

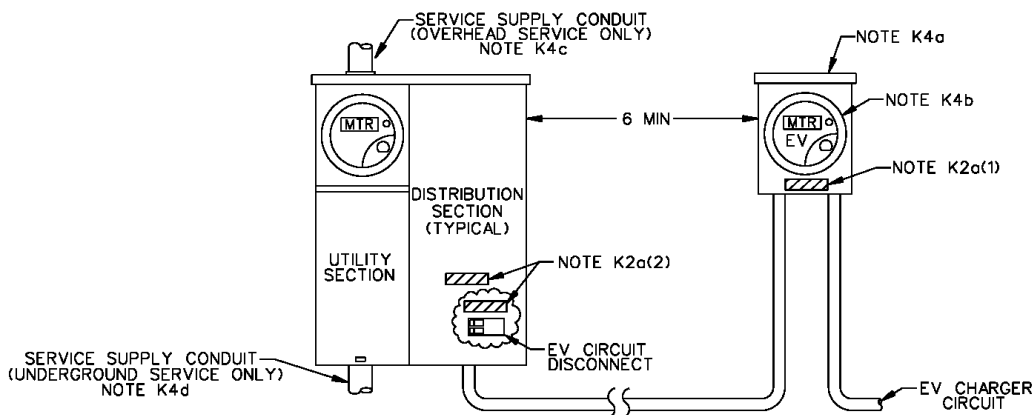

FIGURE 3

K. ELECTRIC VEHICLE INSTALLATIONS**1. GENERAL**

- a. This section is intended to assist Los Angeles Department of Water and Power (Department) customers in the installation of one or more fast charge level II (typically 240Volts) and high-power fast charge level III (typically 480Volts) residential and commercial chargers.
- b. All customers who plan to install a level II charger to charge their electric vehicles at home should fill out the “EV Charging Station Request Form” and “Residential Rebate Application” available online at www.ladwp.com/EV.
- c. All customers who plan to install a level III charger will require a commercial service installation or upgrade, and should contact the appropriate Department Service Planning office for information. To locate a service planner for your area, go online to www.ladwp.com/findtherightperson or call (213) EMPOWER, (213) 367-6937.
- d. For general information regarding your electric vehicle charger rebates and incentives, contact the EV customer service hotline at (866) 484-0433 or email pluginla@ladwp.com.
- e. Electric rate information is available online at www.ladwp.com/electricrates.

2. SIGNS AND LABELS

- a. The customer shall provide and install the following signs as directed by the Department:
 - (1) A sign at the electric vehicle meter socket box reading: “(address)-**EV(x)**”, where “address” denotes the house suite or unit number, and where “x” denotes the number of the meter socket serving one or more charging stations.
 - (2) A sign at the electric vehicle main disconnect reading:
“**Dedicated to EV charging only; other loads must not be connected**”
- b. All electric vehicle signs shall be engraved metal or phenolic plastic with 3/8” high (or made to fit device) white block lettering on a contrasting red background.
- c. All signs shall be fastened in an approved manner (heavy-duty waterproof mounting tape or polyurethane based glue) to the meter socket panel and disconnect associated with the electric vehicle service.

3. METERING

- a. Customers shall provide Department approved electric vehicle metering arrangements for the installation of Department-owned meters as follows:
 - (1) Standard meter, or whole house Time of Use meter (TOU), see page 5-31 (figure 1)
 - (2) Separate (dedicated) electric vehicle TOU meter and disconnect, see page 5-31 (figure 2)
 - (3) Electric vehicle statistical meter, see page 5-31 (figure 3)
- b. Whether the service connection is overhead or underground, the **line side (top of meter)** of the Department revenue meter used for billing or statistical meter used for incentives shall be connected to the **Department service connection side**, and the **load side** (bottom of meter) shall be connected to the customer’s electric vehicle main disconnect.
- c. Electric vehicle statistical meters and vehicle chargers may be collocated if a location map is provided at the revenue meter, see pages 5-7 and 5-8.

K. ELECTRIC VEHICLE INSTALLATIONS (Cont.)

- d. In order to facilitate the Department's electrification transportation goal, the Department may, at customer's cost, allow one additional dedicated EV supply point per premises if the following conditions are met:

- (1) The additional supply point is for EV charging stations only and,
- (2) Is located more than 150' from any other existing supply points and,
- (3) In the Department's judgment it is not practical to upgrade existing facilities to accommodate new EV load.

Additional site maps and signage shall be required to identify the locations of all existing and new supply points, meter rooms or meter locations.

4. REFERENCES

- a. Consult with your Electric Service Representative before installing any meter or service equipment. For meter locations, heights, clearances, and working space (0-600V), see pages 5-4, 5-7, 5-12, and 5-20.
- b. For meter sockets and meter socket jaw arrangements, see pages 2-3, 2-4, 2-5 and 2-6.
- c. Service heads are to be grouped together. For overhead service, service head spacing and requirements, see page 7-14.
- d. For underground service conduits, see page 6-2.
- e. For underground pull box requirements, see page 2-8 and 2-16.
- f. For meter room identification, see pages 5-7 and 5-8.

L. SMALL LOT SUBDIVISIONS AND MOBILE HOME PARKS**1. GENERAL**

- a. This section is intended for mobile home parks and projects that are classified under the City of Los Angeles Small Lot Subdivision ordinance (No.176354). This ordinance allows for the subdivision of underutilized land into single-family homes with smaller lot areas, reduced building footprints and reduced yard setbacks, street frontages, passageways between buildings, and open space.
- b. For more information please contact the Department's Tract Design Group, see page 1-4.

2. METERING

- a. Meters and service equipment shall be grouped into common publicly accessible locations unless otherwise approved by the Department.
- b. Barrier posts, or other Department approved protection, shall be furnished and installed by the customer when required working space is exposed to vehicular traffic, hazardous conditions or when otherwise specified by the Department.

3. REFERENCES

- a. For meter locations, heights, clearances, and working space (0-600V), see pages 5-4, 5-7, 5-12, 5-14 and 5-20.
- b. For multiple-metering residential panels, see pages 2-18, 2-24 and 2-25.
- c. For meter sockets and meter socket jaw arrangements, see pages 2-3, 2-4, 2-5 and 2-6.
- d. For barrier post requirements, see page 5-15.

M. ACCESSORY DWELLING UNIT (ADU)**1. GENERAL**

- a. ADU's are classified under State Law and the City of Los Angeles Accessory Dwelling Unit LAMC and Government Code as a unit with a full kitchen and bathroom, which is an accessory use to a primary or main single family residence that cannot be sold separately from the primary or main single family residence. An ADU may also be incorporated within, attached to, or detached from the primary or main single family residential structure and may not exceed 1200 square feet in size.

For more information on specific requirements, contact the Los Angeles Department of Building and Safety and the Los Angeles Department of City Planning.

- b. Construction shall not encroach on Department line facilities, right of ways or easements. For more information on encroachments, contact the Department's Real Estate office, see page 1-7.
- c. When more than one meter will be installed, both attached and detached ADU's shall have a separate and unique legal address(es) that are different from that of the primary residence as approved by the Los Angeles Department of Public Works.
- d. A single service lateral and service point shall be provided per lot or premises.

2. METERING

- a. Unless otherwise approved by the Department, all meters and service equipment shall be grouped into a single location on the primary single-family residence structure in compliance with the Department's service requirements.
- b. For overhead service, the following options are available:
 - (1) Use existing residential meter (with no upgrade) from primary single-family residence.
 - (2) One residential multiple-metering panel with service head(s).
 - (3) Up to two residential meter panels with separate service heads grouped together, see note 7-14 E1(b).
 - (4) A single commercial safety-socket or current-transformer rated meter panel and service head(s).
- c. For underground service with multiple-metering, the terminating pull box and service shall be sized to accommodate both the primary residence and ADU's service ampacity requirements. Where a single meter serves both spaces, a residential, commercial safety-socket or current-transformer rated meter panel with pull box, shall be required.

Note: An increase in service ampacity may dictate a higher equipment fault duty rating, contact the Department for Fault current information.

3. REFERENCES

- a. For meter sockets and meter socket jaw arrangements, see pages 2-3, 2-4, 2-5, and 2-6.
- b. For multiple-metering residential panels, see page 2-24.
- c. For safety socket panels, see pages 2-26 to 2-33.
- d. For underground pull box, see pages 2-15, 2-16 and 2-17.
- e. For meter locations, heights, clearances, and working space (0-600V), see pages 5-4 to 5-14.
- f. For overhead service, drops, clearances, attachments and service heads, see pages 7-2 to 7-21.
- g. For Fault Current information, see page 1-28.
- h. For construction in the proximity to overhead power lines, refer to Department Standard OA006-01.

**THIS PAGE LEFT
INTENTIONALLY BLANK**

CONTENTS

	<u>PAGE</u>
A. General	6-2
B. Jurisdiction	6-2
C. Excavations	6-2
1. Public Property and Easements	6-2
2. Permit Requirements	6-2
3. Locating and Marking Existing Conduits and Substructures (Dig Alert)	6-2
D. Service Locations and Connections	6-2
E. Number and Size of Conduits:	
1. Residential Services	6-3
2. Commercial and Industrial Services	6-3
F. Types of Conduit:	
1. Nonmetallic Conduit	6-3
2. Metallic Conduit	6-4
G. Conduit Depth	6-4
H. Conduit Bends	6-4
I. Conduit Spacing	6-5
J. Concrete Encasement	6-5
K. Conduit Risers:	
1. Service Risers	6-6
2. Pole Risers	6-6
L. Swabbing and Mandrelling	6-6
M. Pull Tape	6-6
N. Conduit Entering a Building Structure	6-7

A. GENERAL

1. All underground installations shall comply with the Rules of the Department of Water and Power (Department) and these Electric Service Requirements.
2. Whenever an installation does not meet the requirements specified in these service requirements, the Department will require the customer to make the necessary changes or corrections at the customer's expense.

NOTE: See the Department's *Common Service and Construction Standards for Underground Conduit and Substructures – Specification 104* for additional construction requirements.

3. Customers are required to contact the Department to determine the location of the underground supply point on the customer's premises and connect the customer-installed conduit to the Department's conduits as specified.

B. JURISDICTION

1. The Department has design and inspection jurisdiction for all structures (i.e., vaults, transformer pads, maintenance holes, handholes, etc.) located on the customer's premises and used for placement of Department-owned equipment.
2. The Department has design and inspection jurisdiction for all distribution conduits and service supply (lateral) conduits installed outside of buildings or under buildings under at least 2-inches of concrete and used for the installation of Department-owned conductors.
3. The Department has joint design and inspection jurisdiction with the permitting agency over all distribution and service supply conduits installed through buildings and used for installation of Department-owned conductors. For primary, secondary and service supply conduits installed through the interior of buildings, see page 6-7, **CONDUIT ENTERING A BUILDING STRUCTURE**, for minimum Department requirements.

C. EXCAVATIONS**1. PUBLIC PROPERTY AND EASEMENTS**

Consult the Department for any conduit installation on public property or on Department easements.

2. PERMIT REQUIREMENTS

The Department is required to obtain a street excavation permit before starting construction in any public way (i.e., street, road, alley, walk, parkway, or similar dedicated thoroughfare).

3. LOCATING AND MARKING EXISTING CONDUITS AND SUBSTRUCTURES

The State of California (Government Code 4216) requires that anyone doing excavation work shall call at least two (2) working days prior to starting the excavation. If you are performing this type of work, call Underground Service Alert (Dig Alert) - see page 2 for telephone numbers.

D. SERVICE LOCATIONS AND CONNECTIONS

1. When a residential lot with an existing single underground service supply conduit is subdivided, the property owner is required to provide a new supply conduit from an underground source designated by the Department to each new lot not supplied by the original supply conduit.
2. When two or more residential buildings are provided on a lot to which a single service supply conduit has been provided by the owner or former owner, the customer may be required to provide a new conduit from a substructure designated by the Department to each new building.

D. SERVICE LOCATIONS AND CONNECTIONS (Cont.)

- 3. No more than one underground service location will be permitted for any premises, except:
 - a. Additional service locations may be permitted if more than one building occupies the premises, and the wiring layout has been submitted to the Department engineers and approved by them as the most desirable serving arrangement.
 - b. Additional locations may be required for the Department's operating convenience or necessity.
- 4. Customers are required to determine the supply point from which the Department will provide service to a premises and shall connect the customer-owned conduits to the Department conduits specified if they are provided.

E. NUMBER AND SIZE OF CONDUITS

1. RESIDENTIAL SERVICES

- a. For single-family dwellings, conduits shall be sized as follows:

Service Ampacity (Single-Phase Only)	Conduit Length on Private Property	
	0 - 100 feet	101 - 200 feet
0 – 320	3" min.	3" min.
400	3" min.	4" min.

Note: Where the length of conduit on private property exceeds 200 feet, conduit exists or where service capacity exceeds 400 amperes, consult the Department regarding the number and size of conduits required.

- b. For multi-occupancy buildings, consult with the appropriate Department engineering office for conduit requirements. See **ENGINEERING OFFICES**, Page 1-4, for locations and telephone numbers.
- c. In general, a conduit is required for each 400 amperes of service ampacity. The Department may require the installation of spare conduits for the purpose of maintaining service reliability.

2. COMMERCIAL AND INDUSTRIAL SERVICES

- a. Consult with the appropriate Department engineering office for conduit requirements. See **ENGINEERING OFFICES**, Page 1-4, for locations and telephone numbers.
- b. In general, a conduit is required for each 400 amperes of service ampacity. The Department may require the installation of spare conduits for the purpose of maintaining service reliability.
- c. Conduits for fiber-optics applications are generally required for installations requiring that dedicated transformer facilities be located on the customer's premises. For application and installation requirements, see page 5-22.

F. TYPES OF CONDUITS

1. NONMETALLIC CONDUITS

- a. Conduits listed by the Underwriters Laboratories (UL) as rigid, nonmetallic, underground electrical conduit are acceptable as designated for concrete encasement or direct buried use. Nonmetallic conduits shall **not** be:

F. TYPES OF CONDUITS (Cont.)

- (1) Used in non-compacted filled ground unless encased in concrete with reinforcing bars (rebar) in the concrete envelope. Four #4 bars shall be placed, one in each corner of the concrete envelope, parallel to the conduit run with a minimum cover of 1-1/2 inches.
 - (2) Installed in sloping terrain where any 40-foot section of the conduit run exceeds 30-degrees from horizontal or where otherwise specified by the Department.
- b. PVC plastic conduit shall comply with ASTM F-512. Type DB-120 (minimum) conduit is required when the conduit is to be concrete encased. Type DB-120 (minimum) conduit is required when conduit is to be direct buried and for all conduit bends. **ABS plastic conduit is not acceptable.**
 - c. Plastic conduit must be labeled and installed so that the label is visible.
 - d. Plastic conduit joints must be primed and cement welded. Primer shall be tinted and shall comply with ASTM F656. Cement shall comply with ASTM D2564 (heavy-bodied, medium set).
 - e. Joints must be tightly fitted and butted. Deflections in the conduit run will not be permitted by loose fitting or forcing of conduit fittings.
 - f. The bottom of trenches shall be level and uniformly graded so as to be smooth and free of rocks so that conduits will not be damaged when the trench is backfilled. Trenches must be backfilled before the Department will install cable in the conduit.

2. METALLIC CONDUITS

- a. Galvanized rigid steel conduit (GRC) may be used under all conditions for low-voltage services. Intermediate metallic conduit (IMC) may be used as an alternate to GRC for low-voltage services except where exposed to traffic.
- b. Galvanized rigid steel conduit (GRC) may be used for voltages greater than 600V only where specified by the Department.
- c. All metallic conduits shall be hot-dipped galvanized.
- d. Running-fit type connections are not permitted.

G. CONDUIT DEPTH

1. Conduit runs shall be installed at the following depths as measured from the top of the conduits or concrete envelope to finished grade:
 - a. Secondary conduits (under 600 volts) - 24 inches in either paved or landscaped areas.
 - b. Primary conduits (over 600 volts) - 30 inches (minimum) in paved areas and 36 inches (minimum) in landscaped areas.
2. Conduits terminated and capped at the property line shall be installed at a minimum depth of 30 inches as measured from the top of the conduits or concrete envelope to gutter grade.

Exception: When supplied from overhead facilities (pole dips), the minimum depth shall be 36 inches for conduit diameters up to 4 inches and 60 inches for conduit diameters exceeding 4 inches.
3. Changes in depth in any conduit run shall conform to the requirements for bends.

H. CONDUIT BENDS

1. Conduit bends in horizontal runs of conduit and bends used to rise at the service shall be provided as follows:
 - a. For conduits up to 4 inches: 3 foot minimum radius bends.
 - b. For conduits exceeding 4 inches: 4 foot minimum radius bends.
2. Conduit bends used to rise from underground at pole risers shall be provided as follows unless otherwise specified by the Department:
 - a. For conduits up to 4 inches: 3 foot minimum radius bends.
 - b. For conduits exceeding 4 inches: 5 foot minimum radius bends.
3. Conduit bends used to rise from underground:
 - a. At pole risers shall be of GRC or IMC conduit except where otherwise specified by the Department.
 - b. At the service may be of GRC, IMC, or PVC plastic conduit.
4. Straight lengths of conduit may be cold bent in the trench as follows:

Conduit Size	Minimum Bend Radius
3" - 6"	65 feet

Note: Heat-treated field bending of plastic conduit is not permitted.

5. Each run of conduit shall be limited to a maximum of one 45-degree and two 90-degree bends unless otherwise specified by the Department.

I. CONDUIT SPACING

1. A minimum of 2 inch spacing is required between all electric conduits in any run of conduit. If conduits are placed on top of each other, conduit spacers or a 2-inch sand layer may be used to provide the required spacing. If conduits are stacked more than two high, conduits spacers are required.
2. Conduit spacers shall be self-supporting without transmitting a vertical force to the conduits, and be installed with the following intervals:

Duct Size	Maximum Spacing
3"	8 feet
4" - 6"	6 feet

3. A minimum spacing of 12 inches is required between the electric conduits and other conduits installed parallel in the trench. Conduits crossing the trench shall maintain a minimum 6-inch spacing to the electric conduit.

J. CONCRETE ENCASEMENT

- All conduits enclosing 34,500-volt conductors and other conduits, when specified by the Department, shall be encased in a minimum 3-inch concrete envelope using the Department's concrete mix no. 330-C-1700. Small batches of concrete may be mixed on the job site as follows:

Proportion by Loose Dry Volume			Water (gal. per cu. yd.)	Strength (28 day) p.s.i.
Cement	Concrete Sand	#4 Aggregate		
1	3	5	See Note	1700

Note: Ingredients are to be measured and mixed with an amount of water needed to produce a workable mixture. Each batch is to be in the machine for not less than two minutes after all the ingredients are in the mixture.

- A minimum of 2 inches of spacing is required between conduits.
- Tie and fasten all conduits to prevent floating. Do not encircle conduit with metallic fasteners.

K. CONDUIT RISERS

1. SERVICE RISERS

Riser conduits above grade at the service may be either GRC or IMC.

Exception: Riser conduits exposed to vehicular damage shall be GRC.

2. POLE RISERS

- One 10-foot length of PVC Schedule 80 conduit shall be installed by the customer for each conduit riser required.
- Riser conduits shall be installed plumb with, and against, the pole in the quadrant specified by the Department.
- PVC schedule 80 conduit less than 2-1/2 inches shall not be used as riser conduit except to enclose ground wires.

L. SWABBING AND MANDRELLING

- Each installed conduit shall be swabbed to remove foreign material.
- The Department may require that a mandrel be hand-pulled through any conduit installation to ensure that the conduit is properly installed and clear.

Note: All concrete encased conduits shall be mandrelled.

- A cylindrical mandrel having an outside diameter of 1/4 inch less than the inside diameter of the conduit will be supplied by the Department.

M. PULL TAPE

- A pull tape shall be provided in each completed conduit. The tape shall be secured at both ends and provided with a minimum of 5 feet of slack.

Note: The Department no longer accepts 1/8-inch polypropylene rope.

M. PULL TAPE (Cont.)

2. Pull tape shall be a woven multi-fiber polyester ribbon with a minimum width of 3/8-inch. The tape shall be permanently printed with the rated tensile strength (1250 pounds minimum) and sequential footage markings.
3. The pull tape shall be in one continuous length without any cuts or ties.

N. CONDUIT IN A BUILDING STRUCTURE

1. Conduits will only be allowed to enter a building if they will terminate within the building they enter, reaching either into the indoor station room or electric meter room.
2. When distribution or service supply conduits both primary and secondary are located on or in walls or ceilings (not buried) of a structure or a building (parking structures, basements, etc.) the following minimum requirements shall apply:
 - a. Galvanized rigid steel (GRC) type electrical conduit shall be used.
 - b. Conduit shall be encased in a minimum of 6 inches of structurally supported concrete.
 - c. Exposed conduit duct bank shall be permanently identified with signage indicating "Caution - High Voltage Encased Utility Conduit" every 3 feet.
 - d. Red dye shall be used throughout the concrete encasement.
3. Conduit duct bank shall be designed by a registered civil or structural engineer and included in the Customer's AHJ structural permit. A stamped and approved set of drawings shall be submitted to the Department prior to the start of construction.
4. Conduit shall not be located within or pass through any utility easement.

**THIS PAGE LEFT
INTENTIONALLY BLANK**

CONTENTS

	<u>PAGE</u>
A. General	7-2
B. Service Drops	7-2
1. General	7-2
2. Allowable Length	7-2
3. Number of Service Drops	7-2
C. Service Drop Clearances	7-4
1. General	7-4
2. Clearances from Buildings	7-4
3. Clearances over Walkways, Driveways, and Thoroughfares – Public and Private Property	7-6
4. Clearances over Swimming Pools	7-8
5. Clearances from Signs	7-9
6. Clearances from other Conductors	7-9
D. Service Drop Attachments	7-9
1. General	7-9
2. Attachment Locations and Clearances	7-10
3. Typical Methods of Attaching Service drops on Building Walls	7-12
4. Typical Methods of Attaching service Drops Above Building Roofs	7-13
E. Service Heads	7-14
1. General	7-14
2. Riser Conduits	7-14
3. Service Entrance Conductors	7-14
4. Busway Services	7-15
5. Locations	7-15
6. Replacement or Additional Service Heads	7-16
F. Structures for Clearance	7-16
1. General	7-16
2. Angle Iron Racks	7-16
3. Conduit Attachment Risers and Wood Attachment Risers	7-16
4. Customer-Owned Service Poles	7-16
Illustrations:	
Angle Iron Racks	7-17
Galvanized Rigid Risers for Service Attachments Above the Roof	7-18
Solid Wood Risers for Service Attachments Above the Roof	7-20
Customer-Owned Temporary Service Pole (one year maximum service)	7-22
Customer-Owned Permanent/Temporary Wood Service Pole	7-24
Customer-Owned Permanent/Temporary Metal Service Pole	7-26
Customer-Owned Permanent/Temporary Service Pole with Pedestal	7-28

A. GENERAL

1. Overhead service will not be supplied to any premises located in an area designated by the Department as an underground district.
2. The Department is converting some areas from overhead distribution to underground distribution. In such areas where overhead electric lines are present, the Department may require the service to be supplied from underground facilities, or from overhead facilities with provisions for future underground conversion.
3. The Department reserves the right to supply service to more than one customer from any pole or pole rack located in public property or on private property by easement or permit.
4. Construction shall not encroach on Department line facilities, right of ways or easements. For more information on encroachments, contact the Department's Real Estate office, see page 1-7.

B. SERVICE DROPS

1. GENERAL

- a. The Department will furnish and install a single span of service wires (service drop) from the closest available Department pole to the customer's approved point of service. The service drop shall pass only over the premises served.
- b. The Department will determine the number of service drops to be supplied to any building or premises.
- c. Additional requirements apply to accessory dwelling units (ADU), see page 5-33 for details.

2. ALLOWABLE LENGTH

The maximum length of a span of service drop conductors depends on the slope or grade of the land, intervening trees or structures, and the size of the conductors to be used, but shall not exceed 150 feet.

3. NUMBER OF SERVICE DROPS

Normally, only one service drop will be provided to any building or structure for each allowed class of service.

Exceptions:

- a. A building may be permitted additional service drops for each allowed class of service provided the service drops are more than 150 feet apart as measured in a straight line and are supplied from the existing pole line or if otherwise required for the Department's operating convenience or necessity.

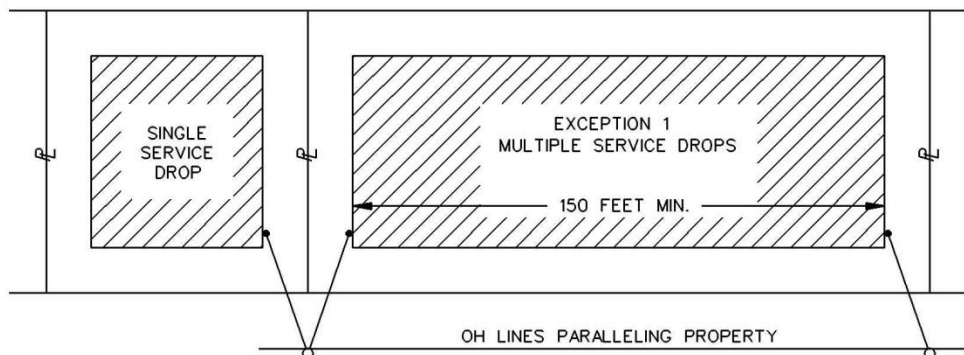

FIGURE 1

B. SERVICE DROPS (Cont.)

b. Where a group of residential buildings located on a single lot:

1. Extending up to 150 feet along and facing (paralleling) the pole line supplying service to the lot, a maximum of two service drops may be permitted for each allowed class of service, unless otherwise required for the Department's operating convenience or necessity.

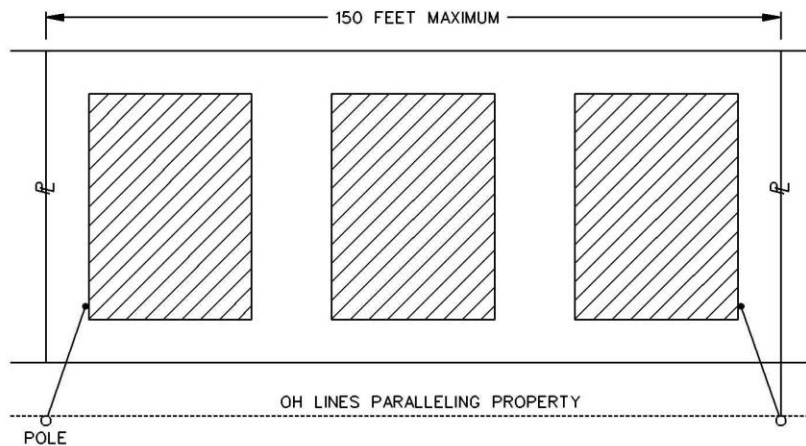

FIGURE 2

2. Extending more than 150 feet along and facing (paralleling) the pole line supplying service to the lot, additional service drops may be permitted for each allowed class of service provided the service drops are more than 150 feet apart as measured in a straight line, or if required for the Department's operating convenience or necessity.

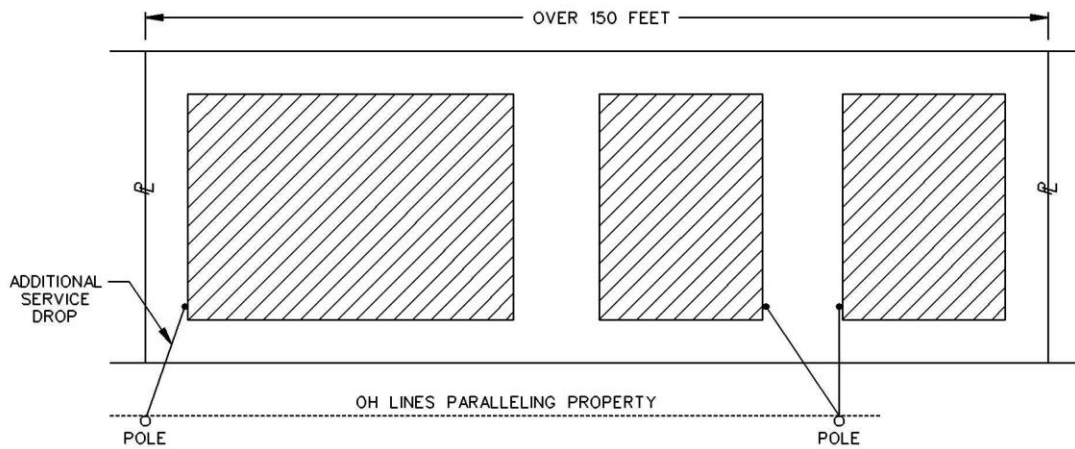

FIGURE 3

C. SERVICE DROP CONDUCTOR CLEARANCES

1. GENERAL

- a. The minimum clearance for service drop conductors to the ground, structures, and other objects is specified in General Order 95 (G. O. 95) of the California Public Utilities Commission. Unless otherwise indicated, all clearances specified in this section are based on the use of insulated, abrasion-resistant service drop conductors.
- b. Service heads, support structures, and points of attachment shall be located to provide the required clearances as measured from the lowest point of the service drop, including the drip loop.
- c. When an existing service drop clearance is impaired because of changes made to premises by a customer, either the owner or tenant, the customer shall provide the means to correct the clearance violation at the customer's cost. If it is necessary for the Department to relocate the service drop to correct the impaired clearances, the customer shall reimburse the Department for the Department's costs.

2. CLEARANCES FROM BUILDINGS

a. Vertical Clearances Above:

	Minimum Clearance from Buildings	
	Non-Insulated Conductors (WP)	Insulated Abrasion Resistant Conductors (IAR)
(1) Building served - All portions of building including metallic or non-metallic cornice, decorative appendage, eaves, roof or parapet wall (See page 7-5, fig. 2)	8 feet	1 foot (Note a)
(2) Metallic or non-metallic non-walkable* overhang, car port or patio cover	8 feet	1 foot (Note b)
(3) Other buildings on the same premises (See page 7-5, fig. 2)	8 feet	8 feet

Note a Clearance based on a point of attachment within 18 inches of the exterior wall facing the overhead lines from which the service will be supplied and within 30 inches of the roof overhang.

Note b Increase to 8 feet minimum when installed over a metallic roof with less than a 3/8 rise (Approximately 37 degrees as measured from the horizontal). See figure 1.

* **Non-walkable:** Those surfaces not normally intended to support humans such as, but not limited to, handrails, fences, walls, chimneys, parapet walls, cornices, aluminum or lath patio covers and decorative appendages or other light material used for patio covers.

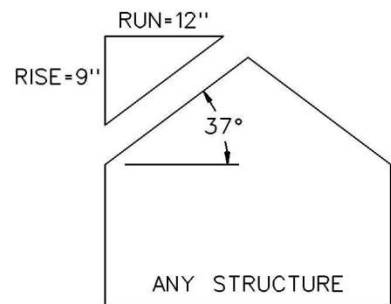

FIGURE 1

C. SERVICE DROP CONDUCTOR CLEARANCES (Cont.)

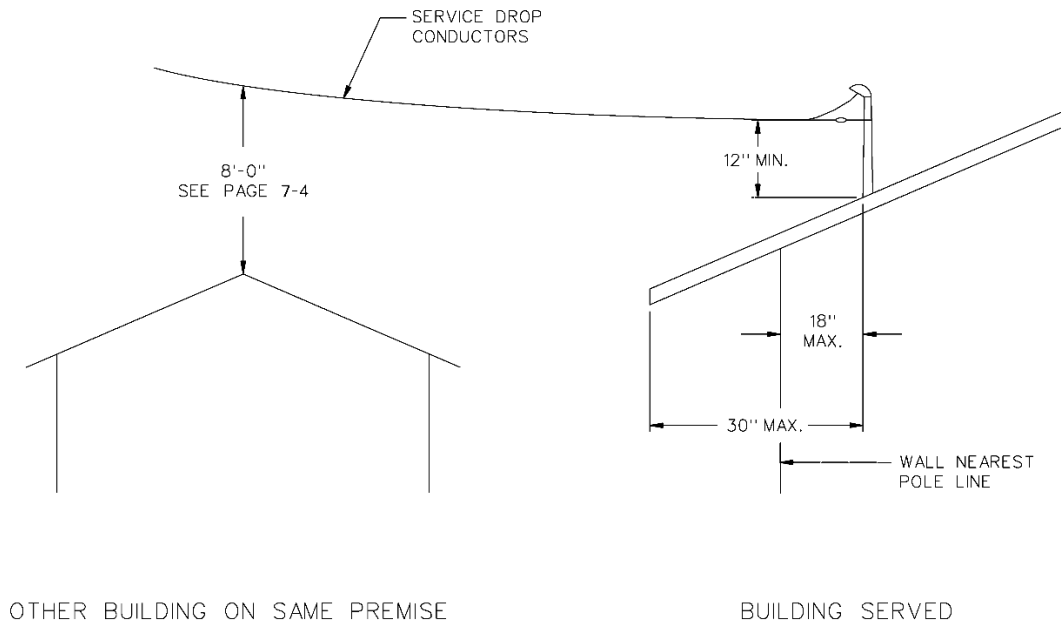

FIGURE 2

- b. Horizontal and Radial Clearances from operable windows, doors, exits, fire escapes, balconies, stairways, walkways. 3 feet

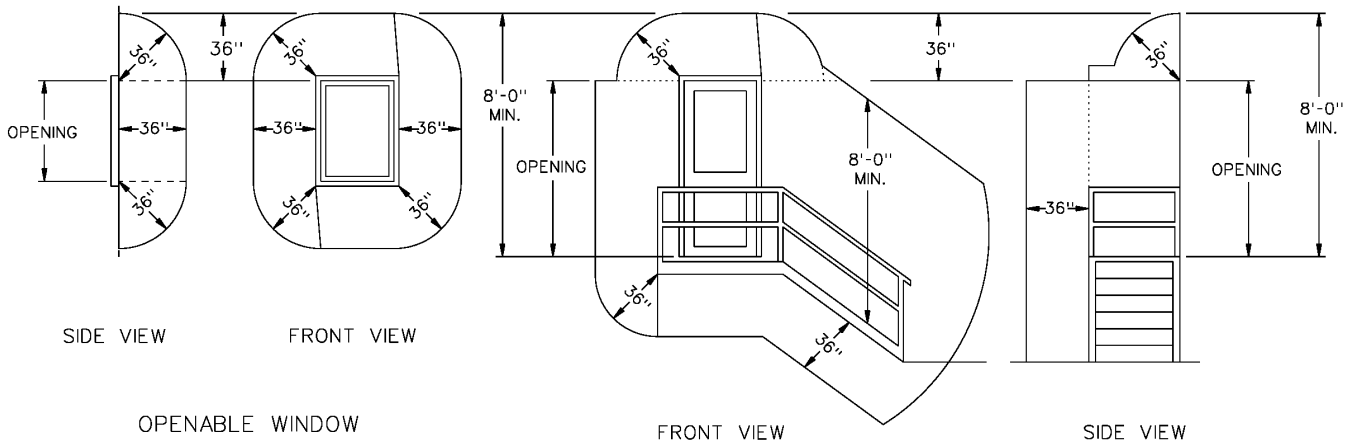

FIGURE 3

C. SERVICE DROP CONDUCTOR CLEARANCES (Cont.)

3. CLEARANCES OVER WALKWAYS, DRIVEWAYS, AND THOROUGHFARES - PUBLIC AND PRIVATE PROPERTY

Vertical clearances above ground for service drops crossing over public and private thoroughfares, driveways and properties shall conform to the following minimum clearances - Conductors:

<u>Condition</u>	<u>Minimum Clearance</u>
a. Crossing areas which are accessible only to pedestrians on all premises	10 feet
b. Crossing over private driveways or other areas accessible to vehicles on:	
(1) Residential Premises	12 feet
(2) Commercial or industrial premises	16 feet
c. Crossing premises accessible to agricultural equipment	15 feet
d. Crossing public thoroughfares	18 feet
This clearance may grade from 18 feet at a position of not more than 12 feet from the curb line to a minimum clearance at the curb line of	16 feet
Note: If no curb exists, the outer limits of possible vehicular traffic may be used as the "curb line".	
e. Crossing over, or in proximity to, swimming pools, diving boards, platforms, or slides	See page 7-8
f. Crossing railroad tracks:	
(1) Without overhead trolley wires	25 feet
(2) Operated with overhead trolley wires	26 feet
Note: In all cases, the service drop conductors shall clear trolley wires by not less than 4 feet.	

C. SERVICE DROP CONDUCTOR CLEARANCES (Cont.)

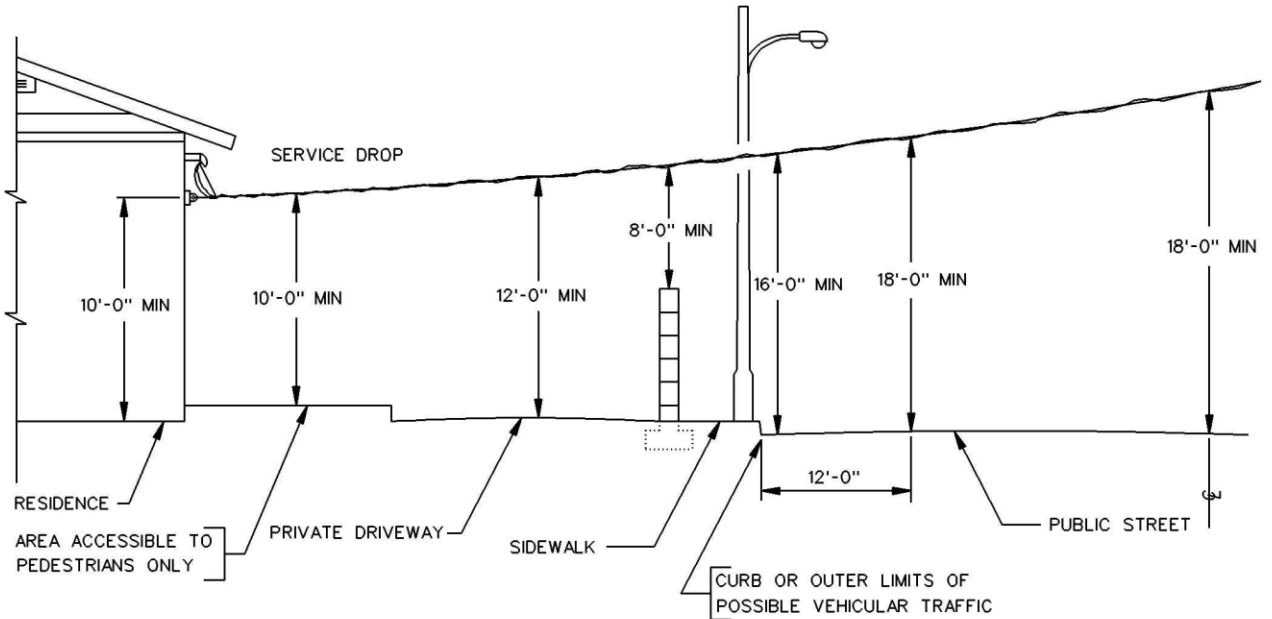

SERVICE DROP CLEARANCES FOR RESIDENTIAL PREMISES

FIGURE 1

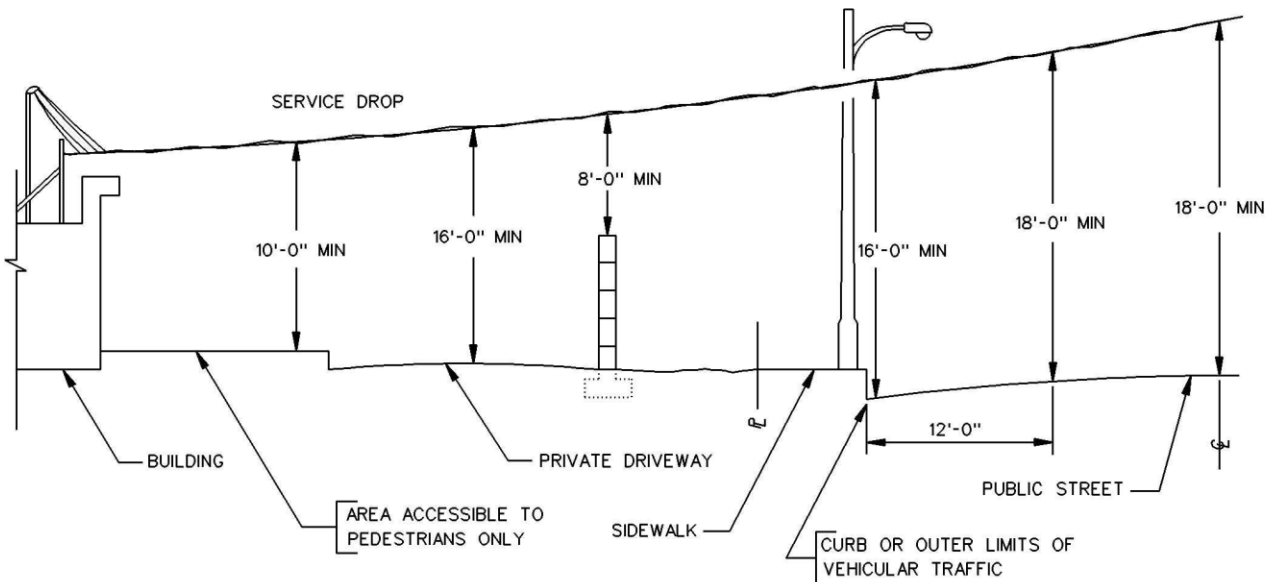

SERVICE DROP CLEARANCES FOR COMMERCIAL AND INDUSTRIAL SERVICES

FIGURE 2

C. SERVICE DROP CONDUCTOR CLEARANCES (Cont.)

4. CLEARANCES OVER SWIMMING POOLS

The installation of swimming pools under existing service drops should be avoided where practical. However, where a swimming pool must be located under existing service drop conductors, the clearances shown in Figure 1 below are required by General Order 95 (California Rules for Overhead Line Construction)

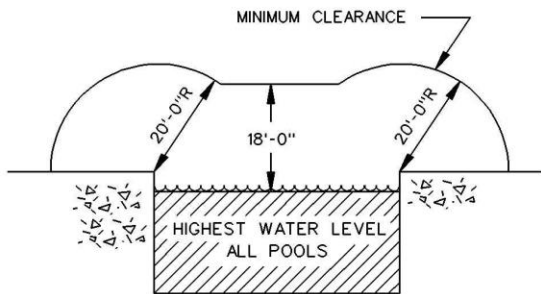

DETAIL A
MINIMUM CLEARANCE FOR OPEN-WIRE DROPS

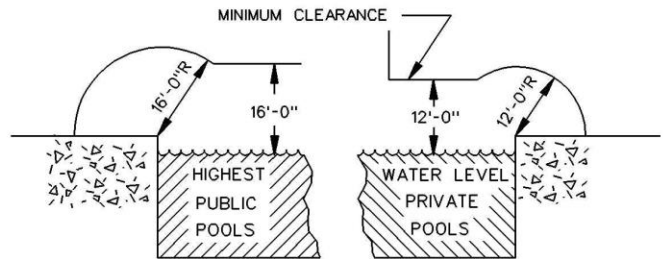

DETAIL B
MINIMUM CLEARANCE FOR DROPS WITH SPECIALLY APPROVED COVERING (0 – 300 VOLTS)

1. TRIPLEX SERVICE CABLE.
2. ABRASION-RESISTANT CABLES HAVING A GROUNDED METALLIC SHEATH (ARMORED SERVICE CABLE).

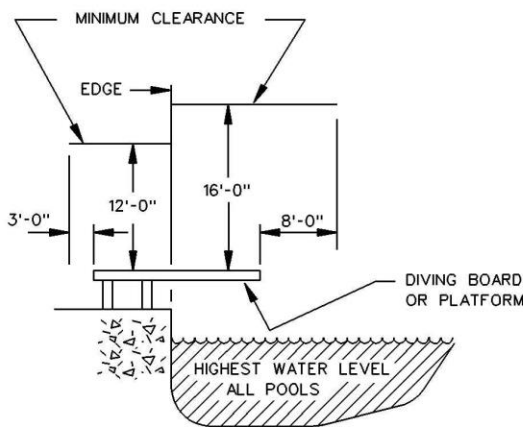

SECTION VIEW

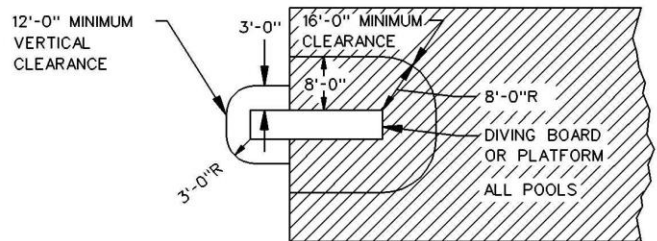

PLAN VIEW

DETAIL C

MINIMUM CLEARANCE FOR DROPS ABOVE OR ADJACENT TO DIVING BOARDS AND PLATFORMS

FIGURE 1

C. SERVICE DROP CONDUCTOR CLEARANCES (Cont.)**5. CLEARANCES FROM SIGNS**

The vertical and horizontal service drop clearance conductor from signs, whether mounted on buildings or isolated structures shall not be less than the following minimum clearances:

<u>Condition</u>	<u>Minimum Clearance</u>
a. Vertical clearance above signs without walkable surfaces	2 feet
b. Vertical clearance above surfaces of signs upon which persons might walk	8 feet
c. Vertical clearance under signs that are	
(1) Illuminated	2 feet
(2) Non-illuminated	1 foot
d. Horizontal clearance from signs which are:	
(1) Illuminated	3 feet
(2) Non-illuminated	1 foot

6. CLEARANCES FROM OTHER CONDUCTORS

Service drop conductor clearance from telephone and CATV service drop conductors at crossings, and radially where approaching crossings, shall not be less than 2 feet

Exception: This clearance may be reduced to 1 foot within 15 feet of the point of attachment on the building or structure. For additional information, see Attachment Locations and Clearances on page 7-10 and Conduit Risers and Wood Attachment Risers on pages 7-16, 7-18 and 7-20.

D. SERVICE DROP ATTACHMENTS**1. GENERAL**

- a. On request, a Department service planner will provide assistance in determining a location for the service drop attachment to provide the required clearance for the Department's service drop conductors. See page 1-4 for service planning office locations and telephone numbers.
- b. The Department will normally furnish and install standard wire holders (brackets) except as follows:
 - (1) The customer shall install standard brackets supplied by the Department on buildings constructed of concrete, brick, wood, or finished stucco.
 - (2) The customer will furnish and install any special brackets, racks, or structures required by the Department.
- c. Attachment brackets shall be installed using through bolts or lag screws as specified by the Department.

D. SERVICE DROP ATTACHMENTS (Cont.)

2. ATTACHMENT LOCATIONS AND CLEARANCES

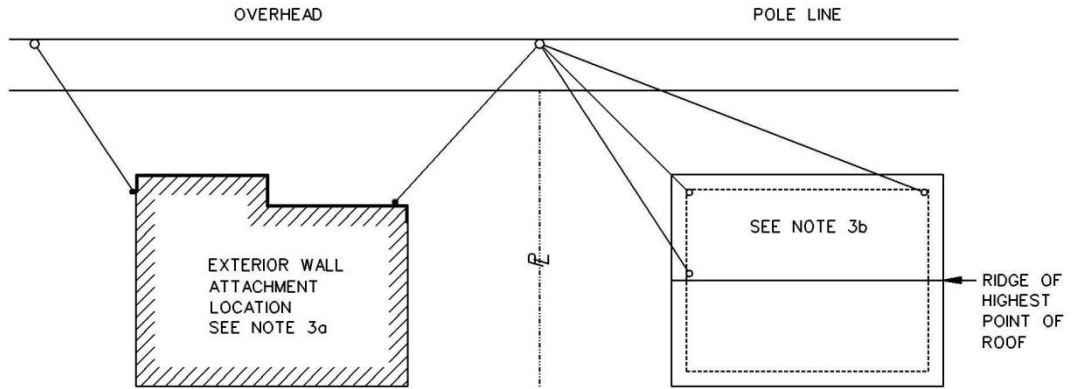

SERVICE DROP ATTACHMENT ON BUILDING WALL NEAREST TO OVERHEAD LINES

FIGURE 1

SERVICE DROP ATTACHMENT ABOVE BUILDING ROOF

FIGURE 2

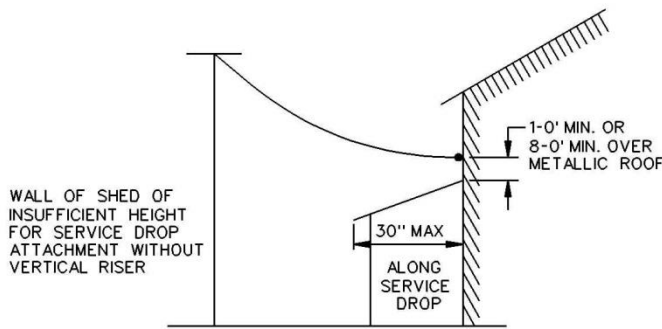

ATTACHMENT ABOVE SHED TYPE STRUCTURE

FIGURE 3

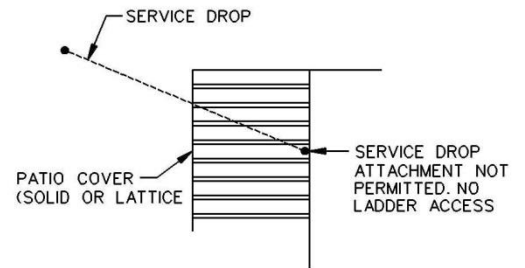

ATTACHMENT ABOVE PATIO COVER

FIGURE 4

- a. The service drop point of attachment shall normally be located on that portion of a building or structure facing and nearest the street, alley, easement or public way on which the Department's pole is located. Attachments shall be installed at a height not less than specified in these requirements to permit service drops to be:
 - (1) Installed and maintained in accordance with vertical, horizontal and radial clearances required above ground and from roofs, obstructions, windows, doorways, openings, balconies, fire escapes swimming pools and other conductors.
 - (2) Run free from trees, structures, poles, masts, antennas, vents, flood lights or other obstructions.

D. SERVICE DROP ATTACHMENTS (Cont.)

- (3) Installed at a location where the weatherhead and point of attachment are safely accessible from a ladder placed on the ground. In general, enough space to provide a "4-to-1" vertical rise is required. When proposed locations will not provide the needed space, consult the appropriate Department service planning office before installing any service equipment or riser conduit.
 - (4) Attached at only one point on the building and without intermediate support.
 - (5) Arranged so as to not hamper or endanger workmen and firemen in the performance of their duties.
- b. The maximum height of the point of attachment is determined by the service head height. For maximum service head height, see page 7-14.
- c. The point of attachment shall be located in either of the following locations:
- (1) On the wall nearest to and facing the overhead electric lines from which service will be supplied or on an adjoining wall within 18 inches of the wall nearest to the overhead lines from which service is to be supplied and where the service drop crosses no intervening part of the structure (See Figure 1).
 - (2) Above the roof on attachment riser or support structure and located:
 - (a) Within 18 inches of the wall nearest to and facing the overhead electric lines from which service is to be supplied and within 30 inches from the edge of the roof overhang and where the service drop crosses no intervening part of the structure (See Figure 2).
 - (b) Within 18 inches of the side wall adjacent to the wall nearest and facing the overhead electric lines from which service will be supplied and within 30 inches of the roof overhang but no further back than the highest point of the roof and where the service drop crosses no intervening part of the structure (See Figure 2).
- Caution:** For points of attachment located above the roof, consult with the Department of Building and Safety where the service drop conductor length over the roof will exceed 4 feet.

D. SERVICE DROP ATTACHMENTS (Cont.)

3. TYPICAL METHODS OF ATTACHING SERVICE DROPS ON BUILDING WALLS

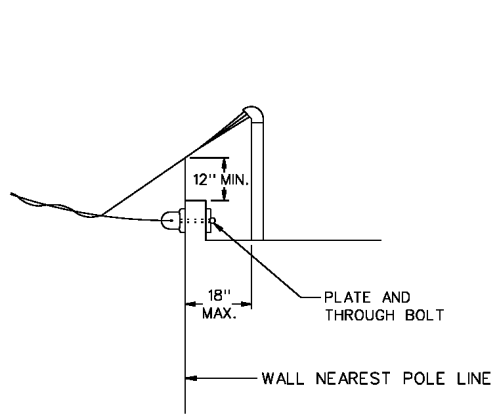

FIGURE 1

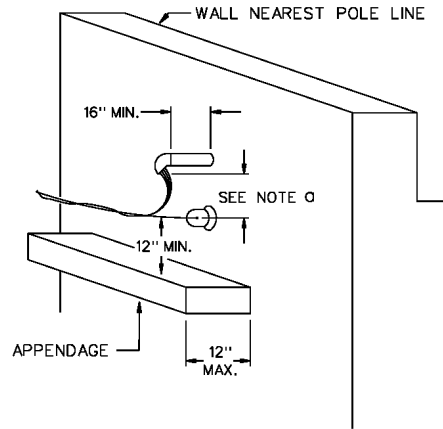

FIGURE 2

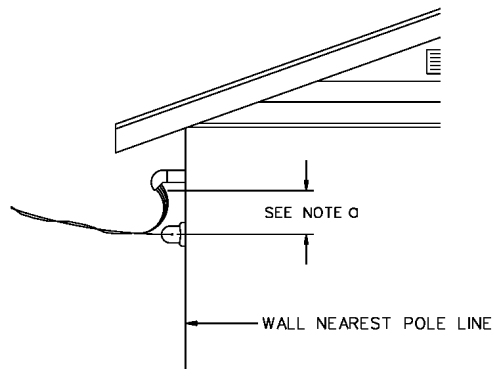
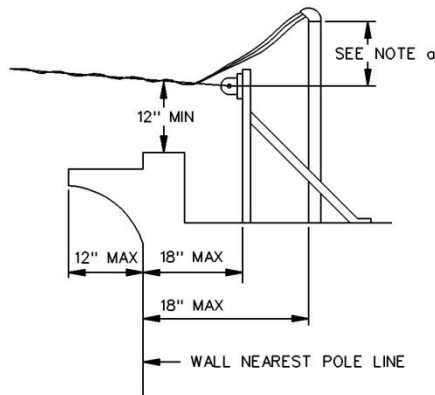

FIGURE 3

- a. Clearance from the attachment bracket to the service head shall not be less than 12 inches for a single-spool bracket or 16 inches for a three-spool bracket (measured from center spool) or a maximum of 30 inches.
- b. For additional service drop clearance requirements, see page 7-4.

D. SERVICE DROP ATTACHMENTS (Cont.)

4. TYPICAL METHODS OF ATTACHING SERVICE DROPS ABOVE BUILDING ROOFS



SEE PAGE 7-17 FOR ANGLE IRON SUPPORT DETAILS

FIGURE 1

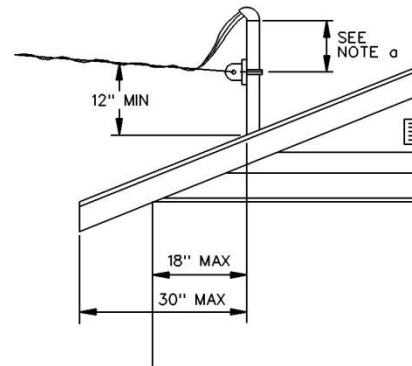

SEE PAGE 7-18 FOR CONDUIT ATTACHMENT RISER DETAILS

FIGURE 2

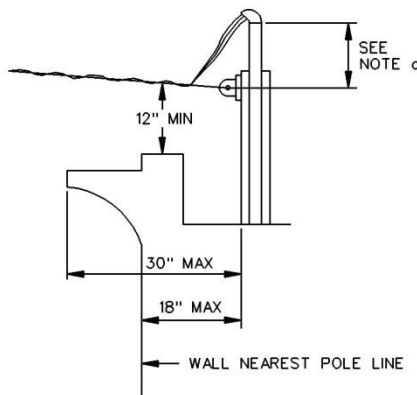

SEE PAGE 7-20 FOR SOLID WOOD ATTACHMENT RISER DETAILS

FIGURE 3

- a. Clearance from the attachment bracket to the service head shall not be less than 12 inches for a single-spool bracket or 16 inches for a three-spool bracket (measured from center spool) or a maximum of 30 inches.
- b. References:
 - (1) For additional service drop clearance requirements, see page 7-3.
 - (2) For angle iron support details, see page 7-17.
 - (3) For conduit attachment riser support details, see page 7-18.
 - (4) For solid wood attachment riser details, see page 7-20.

E. SERVICE HEADS

1. GENERAL

- a. All service heads shall be located as required by the Department but not more than 25 feet above the ground directly below the service head.
- b. Service heads for the same class and voltage shall be grouped together and spaced not less than 9 inches or more than 18 inches apart unless otherwise required for Department convenience.
- c. Service heads for totalized services shall be separated by not less than 18 inches or more than 36 inches.
- d. Service heads of different classes served from the same pole shall be located as close together as practical.
- e. Service heads shall not be located more than 30 inches or less than 12 inches from a single-spool attachment bracket or 16 inches for a three-spool bracket (measured from center spool), except where otherwise specified by the Department.

2. RISER CONDUITS

- a. Conduit attachment risers shall be constructed of galvanized rigid conduit. For all other riser conduits, consult permitting agency.
- b. In general, the service raceway conduit shall be continuous and free of junction boxes and condulets.

Exceptions:

- (1) In single-meter installations, a wireway or conduit may be permitted if the run of riser conduit has excessive length or bends making a continuous run of conduit impractical. Consult with the Department and the appropriate permitting agency before installing any service equipment.
- (2) In multi-meter installations, a sealable, bussed wireway is permitted to serve individual meter enclosures.

Note: When permitted, junction boxes and wireways shall be sealable and installed in locations near metering equipment that are readily visible for perpetual inspection by the Department.

3. SERVICE ENTRANCE CONDUCTORS

- a. The number of service entrance conductors in a riser conduit shall not exceed two conductors per phase and paralleled service entrance conductors shall not be less than 1/0 AWG.

Note: Each run of conductors in a riser conduit shall enclose a complete circuit (i.e., all phase conductors and the associated neutral conductor).

- b. The total number of service entrance conductors at a service head shall not exceed (a) six conductors per service head for a three-wire service or (b) eight conductors per service head for a four-wire service.

- c. The total number of service entrance conductors at a location for each voltage class of service shall not exceed (a) nine conductors for a three-wire service, or (b) twelve conductors for a four-wire service.

Note: This limitation allows for a maximum "3-to-1" splice between the service entrance conductors and the service drop conductors at the service head.

E. SERVICE HEADS (Cont.)

- d. Service entrance conductors shall extend a minimum of three feet beyond the service head unless otherwise specified by the Department. Spliced sections shall not be used to extend the length of the required tails.
- e. The Department shall make connection at the service head between the service drop conductors and the customer's service entrance conductors.
- f. Aluminum service entrance conductors shall be wire brushed and coated with an oxide inhibitor before terminating.

4. BUSWAY SERVICES

A busway service shall be required if the service entrance conductors exceed the number per location or size limits - see **Service Entrance Conductors** above. See page 3-48 for busway service head requirements.

5. LOCATIONS

- a. Customers shall locate and install service heads as specified by the Department.
- b. Service heads shall be located in either of the following locations:
 - (1) On the exterior wall nearest to the overhead electric lines from which the service will be supplied, or on an adjoining wall adjacent to the attachment bracket. For attachment bracket locations and bracket to service head clearance requirements, see page 7-9.
 - (2) Above the roof within 18 inches of the exterior wall nearest to the electric lines from which the service will be supplied and within 30 inches of the roof overhang.
 - Note:** The service head shall generally be installed on the wall or above the roof in the area immediately above the meter. Where the proposed meter location will require a horizontal run of riser conduit to the service head, consult with the permitting agency before installing any service equipment.
- c. Service heads shall not be located:
 - (1) More than 25 feet vertically above the final exterior grade level directly below the service head.
 - (2) On any wall with less than two feet from any common property line common to an adjacent property.
 - Note:** All locations must provide adequate space for safely climbing a ladder to access the service head. In general a 4-to-1 rise is required. When proposed locations will not provide the allowable space, consult the Department before installing any service equipment.
- d. Service heads supplied at the same class of service shall be grouped together and separated by not less than 9 inches or more than 18 inches.
- e. Service heads for different classes of service supplied from the same pole shall be located as close together as practical.
- f. Service heads for separate services that are totalized shall be separated by not less than 18 inches or more than 36 inches.

E. SERVICE HEADS (Cont.)**6. REPLACEMENT OR ADDITIONAL SERVICE HEADS**

No service head shall be replaced or additional service heads installed for connection to existing service drops without prior approval of the Department.

F. STRUCTURES FOR CLEARANCE**1. GENERAL**

- a. Where a structure is necessary to maintain required service drop clearances, the structure shall be installed and maintained by the customer. The structure shall be located on the building served.
- b. While the Department approves support structures, the customer must consult with the appropriate permitting agency regarding structural details and requirements.
- c. Attachment brackets for communication (i.e., telephone, CATV) service drops shall not be installed on any electric service drop riser conduit, riser support or in any location, which obstructs access to the Department's attachment bracket, associated service head(s) or the area between the bracket and the service head(s).

2. ANGLE IRON RACKS

- a. An iron angle rack may be installed in above the roof installations to provide the required service drop conductor clearances.
- b. For angle iron rack construction details, see page 7-17.

3. CONDUIT ATTACHMENT RISERS AND WOOD ATTACHMENT RISERS

- a. Conduit attachment (periscope service) risers or solid wood attachment risers shall be required on all above-roof installations.
- b. Wood attachment risers shall be constructed of a single piece of solid wood - risers that are laminated, or constructed of separate pieces, are not permitted.
- c. Risers to which service drop conductors are attached shall be sufficiently supported to withstand the stresses imposed by the service drop conductors.
- d. For construction details of conduit attachment risers see Page 7-18 and for solid-wood attachment risers see Page 7-20.

4. CUSTOMER SERVICE POLES

For construction details for customer-owned service poles, see:

- a. Page 7-22 for temporary wood poles limited to a maximum one year service.
- b. Page 7-24 for permanent or temporary wood poles.
- c. Page 7-26 for permanent or temporary metal poles.

ANGLE IRON RACKS

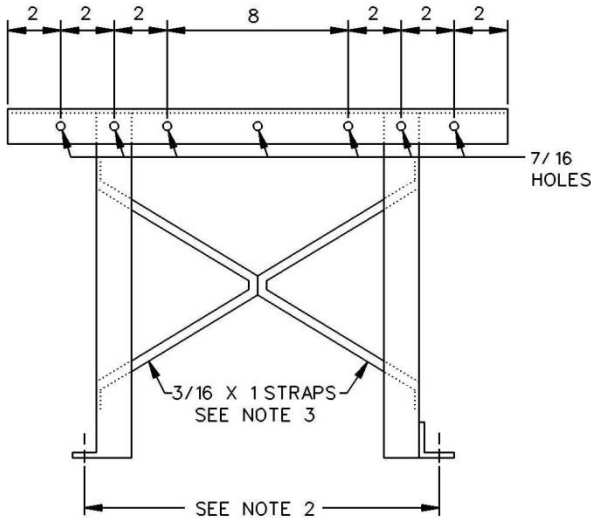

FRONT VIEW

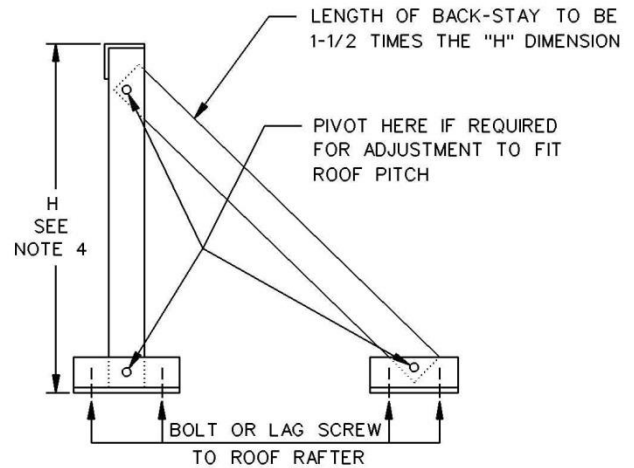

SIDE VIEW

ANGLE IRON SIZE	(H) EXTENSION ABOVE ROOF	MAXIMUM SIZE OF SERVICE ENTRANCE CONDUCTORS	MAXIMUM LENGTH OF SERVICE DROP (FEET)
1-1/4" x 1-1/4" x 1/8"	0" - 30"	# 1 AWG	100
1-1/4" x 1-1/4" x 3/16"	31" - 60"	# 1 AWG	100
1-1/4" x 1-1/4" x 1/4"	0" - 60"	# 3/0	100
1-1/4" x 1-1/4" x 1/4"	61" - 96"	# 3/0	60
2" x 2" x 1/4"	0" - 60"	500 KCMIL	100
2" x 2" x 1/4"	61" - 96"	500 KCMIL	60
CONSULT DEPARTMENT	EXCEEDING ABOVE MAXIMUMS		

NOTES:

1. Angle iron rack members shall be hot-dipped galvanized after fabrication.
2. The dimension of the rack shall be sufficient to permit the anchor plates or angles to be bolted or lagged to the roof rafters. Lag screws shall have a 3/8-inch (minimum) diameter and shall have sufficient length to penetrate the roof rafters by not less than 2-1/2 inches.
3. Galvanized strap cross-brace is necessary where service drop conductors will approach the rack at a horizontal angle of less than 30-degrees. The rack construction illustrated will be suitable for the attachment of the service drops where built as specified in the table above.
4. Extension above roof needed to provide the required service drop clearance.
5. References:
 - a. For application and clearance requirements, see page 7-13.
 - b. For busway service head requirements, see page 3-48.

GALVANIZED RIGID CONDUIT RISERS FOR SERVICE ATTACHMENTS ABOVE THE ROOF

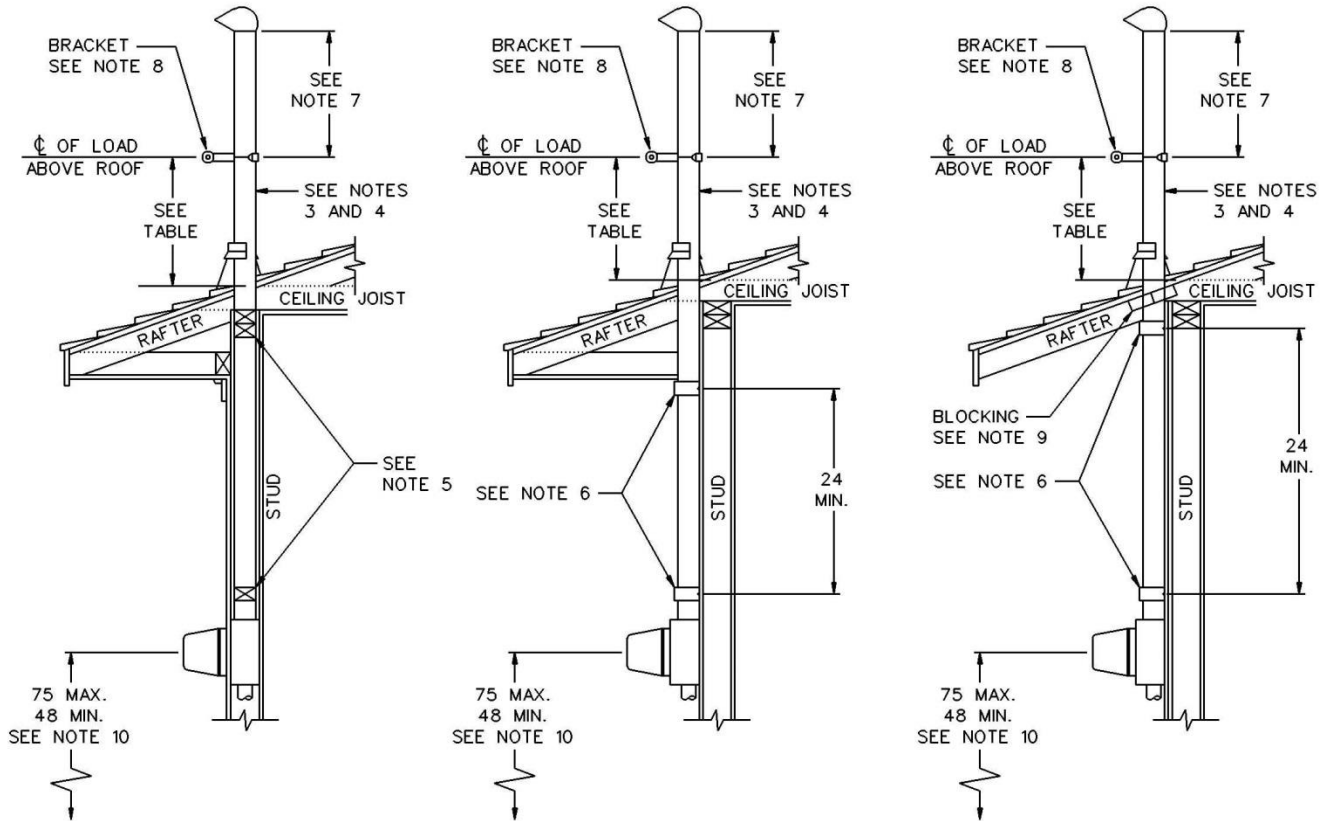

RISER ENCLOSED IN BUILDING WALL

EXPOSED RISER WITH ENCLOSED RAFTERS

EXPOSED RISER WITH OPEN RAFTERS

FIGURE 1

FIGURE 2

FIGURE 3

CONDUIT TRADE SIZE	HEIGHT OF THE CENTER-LINE OF THE LOAD ABOVE THE ROOF	
	MIN.	MAX.
1-1/2"	12"	40"
2"	12"	60"
2-1/2"	12"	80"

NOTES:

1. The arrangements shown above are suggested to provide the required service drop conductor ground and roof clearances as required by the agencies having jurisdiction. The customer should consult the Department and the permitting agency having jurisdiction for other methods of supporting the service drop conductors not shown.
2. The Department is not responsible for any damage to the building caused by rain or structural damage.

GALVANIZED RIGID CONDUIT RISER FOR SERVICE ATTACHMENTS ABOVE THE ROOF (Cont.)

3. The conduit attachment riser shall be constructed of galvanized rigid steel (GRC) and shall be continuous (no couplings) between the top of the riser and the lowest point of support.
4. Service drop attachment risers shall be located within 18 inches of the wall nearest to the overhead lines supplying service and within 30 inches of the roof overhang.
5. Enclosed risers (figure 1) must be securely braced with 1/4-inch x 2-inch steel plates and minimum 3/8-inch U-bolts. Secure bracing to 2-inch x 4-inch plates and studs as shown using minimum 3/8-inch x 3-inch lag screws. For other proposed means of attachment, consult the Department and the Authority Having Jurisdiction (AHJ).
6. Exposed risers (figures 2 and 3) must be securely braced with Unistrut. Secure bracing to 2-inch x 4-inch plates and studs as shown using minimum 3/8-inch x 3-inch lag screws. For other proposed means of attachment, consult the Department and the Authority Having Jurisdiction (AHJ).
7. The clearance from the attachment bracket to the service head shall not be less than 12 inches for a single-spool bracket or 16 inches for a three-spool bracket (measured from the center spool) or more than 30 inches, except where otherwise specified by the Department.
8. Attachment bracket supplied and attached by the Department.
9. Install 2-inch x 4-inch blocking between, and solidly attached to, the rafters.
10. References:
 - a. For service drop attachments, see page 7-9.
 - b. For service drop clearances, see page 7-4.
 - c. For service heads, see page 7-14.
 - d. For acceptable meter locations, see page 5-4.
 - e. For meter clearance and working space requirements, see page 5-12.

SOLID WOOD RISERS FOR SERVICE ATTACHMENTS ABOVE THE ROOF SERVICE

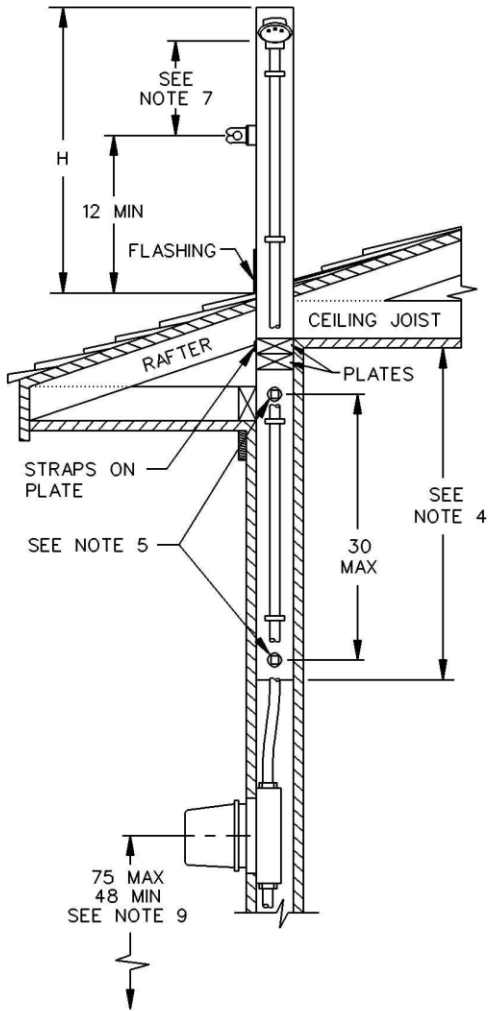

WOOD RISER ENCLOSED
IN BUILDING WALL

FIGURE 1

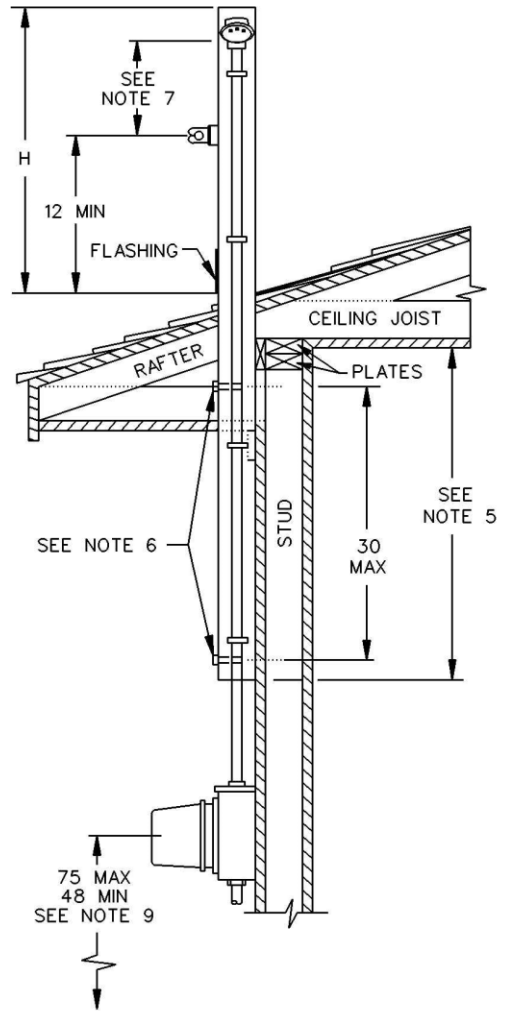

WOOD RISER ATTACHED
TO BUILDING WALL

FIGURE 2

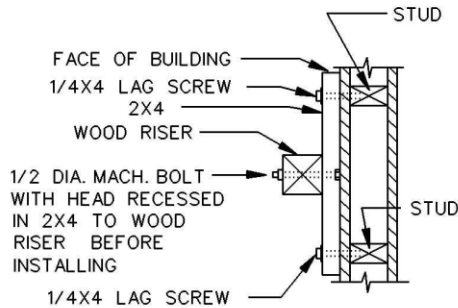

ALTERNATE METHOD OF
SECURING WOOD RISER
TO BUILDING

DETAIL "A" - PLAN VIEW

SOLID WOOD RISERS FOR SERVICE ATTACHMENTS ABOVE THE ROOF SERVICE (Cont.)

DIMENSION OF WOOD RISER	"H" - MAXIMUM RISER HEIGHT ABOVE ROOF (FEET)	MAXIMUM SERVICE ENTRANCE CONDUCTORS (SEE NOTE 9)	MAXIMUM LENGTH OF SERVICE DROP (FEET)
6" x 6"	5	#1 AWG	150
6" x 6"	8	#1 AWG	75

NOTES:

1. The arrangements shown above are suggested to provide the required service drop conductor ground and roof clearances as required by the agencies having jurisdiction. The customer should consult the Department and permitting agency having jurisdiction for other methods of supporting the service drop conductors not shown,
2. The Department is not responsible for any damage to the building caused by rain or structural failure.
3. Wood attachment risers shall be constructed of solid wood - risers that are laminated or constructed of separate pieces are not permitted.
4. The attachment riser shall extend below the building plate a distance equal to the projection above the building plate, but not less than 36 inches.
5. For a wood riser enclosed in a building wall, secure the riser to the wall stud using two 1/2-inch bolts and washers spaced a maximum of 30-inches apart.
6. For a wood riser installed on the exterior of a building wall, secure the riser to the wall stud using 1/2-inch lag screws spaced a maximum of 30-inches apart. See Detail "A" for alternate method of attaching the wood riser to a building wall.
7. The clearance from the attachment bracket to the service head shall not be less than 12 inches for a single-spool bracket or 16 inches for a three-spool bracket (measured from the center spool) or more than 30 inches except where otherwise specified by the Department.
8. For service entrance conductors larger than #1 AWG, consult the Department.
9. References:
 - a. For service drop attachments, see page 7-9.
 - b. For service drop clearances, see page 7-4.
 - c. For service heads, see page 7-14.
 - d. For acceptable meter locations, see page 5-4.
 - e. For meter clearance and working requirements, see page 5-12.

**CUSTOMER-OWNED TEMPORARY SERVICE POLE - One Year Maximum Service
200 AMPERES MAXIMUM, 0-600 VOLTS**

FOR POLES EXCEEDING 24 FEET IN LENGTH, see pages 7-24 and 7-26.

NOTES:

1. The pole shall be self-supporting, solid timber and not less than 6 inches x 6 inches and 20 feet in length. The pole shall be butt-treated and free of knots or other imperfections that could impair the strength of the pole. Laminated poles, or poles constructed of separate pieces, are not permitted.
2. Service drop conductors from the serving pole to the "stinger" and the meter shall be furnished and installed by the Department - all other equipment shall be installed by the contractor.
3. Risers shall be 3/4-inch minimum Polyvinyl Chloride (PVC) schedule 40 or metallic conduit and shall be securely attached to the pole.
4. Floodlights, signs, ropes, and other similar equipment shall not be attached to the pole.
5. The pole shall be located:
 - a. At least 10 feet from the Department service pole and, whenever practicable, at least 10 feet laterally from the center of the pole line but not more than 100 feet from the Department's servicing pole.
 - b. So that the ground clearance, buildings and other obstructions shall not reduce the service drop height below the required minimum clearances specified on pages 7-4 to 7-9.
6. A residential meter socket may be used for 125-ampere, single-phase services - a safety-socket meter panel is required for all others.

Note: The short-circuit duty rating of the service equipment must meet or exceed the Department's fault current value for the installation.

7. Service equipment and receptacles shall be weatherproof, rated for the load to be served and adequately bonded and grounded.

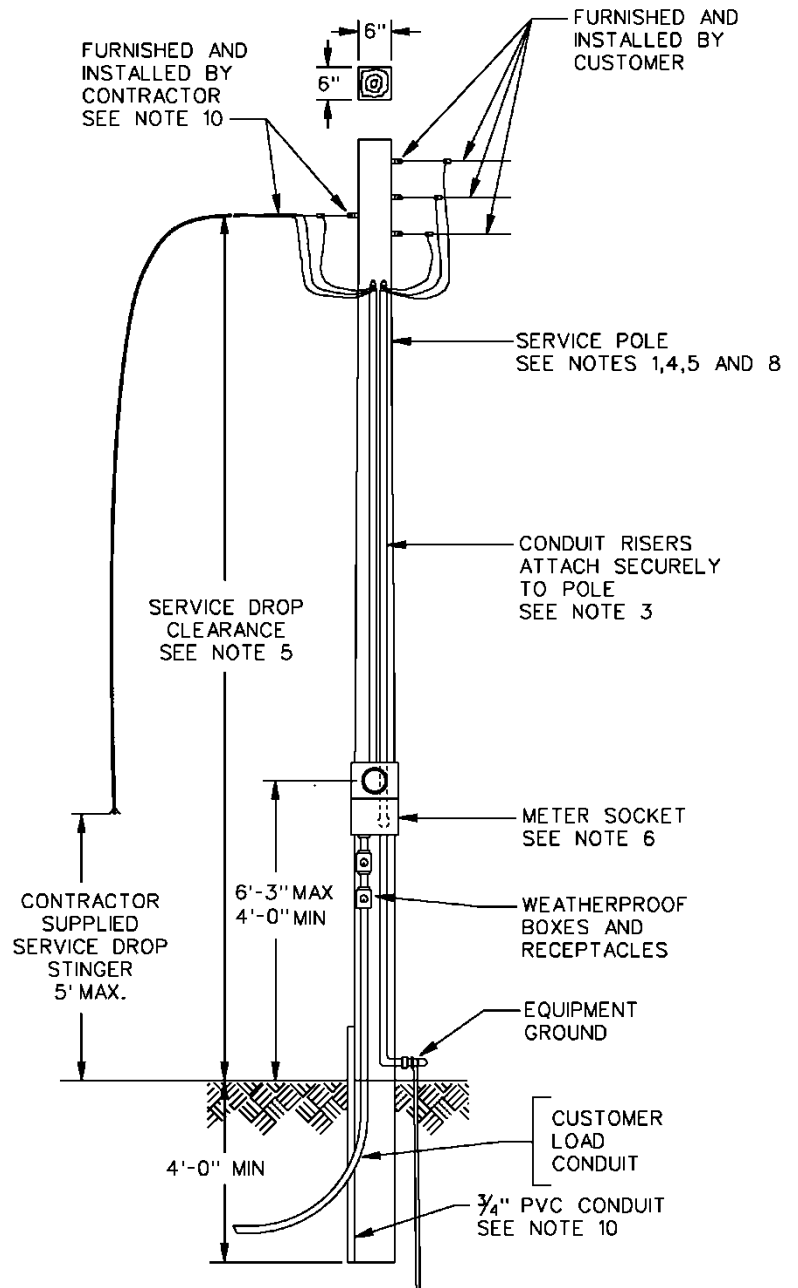

CUSTOMER-OWNED TEMPORARY SERVICE POLE - One Year Maximum Service (Cont.)

8. The numeric portion of the street address shall be provided on the pole on the side facing the street or drivable surface. Plastic or metallic numbers of the type used for house addresses are acceptable.
9. Additional references:
 - a. For safety-socket meter panel details, see pages 2-24 and 2-26.
 - b. Engineering Offices and telephone numbers, see page 1-4.
10. Customer supplied requirements:
 - Minimum "service drop stinger" extension of 10ft.
 - Free end of the "service drop stinger" SHALL be no higher than 5ft above grade level.
 - For 100amp single phase CTS, the "service drop stinger" SHALL be #4 AL triplex.
 - For 200amp single phase CTS, the "service drop stinger" SHALL be #2 AL triplex.
 - For all 3 phase CTS, please consult with the DWP design engineer for "stinger" requirements.
 - The neutral conductor SHALL be bare or identified with white tape at the last 18" of the "stinger".
 - SHALL provide & install a solidly attached insulated point of attachment bracket.
 - SHALL provide & install a "Dead End" strain relief at the point of attachment for the "stinger".
 - Only the neutral SHALL be connected to the strain relief at the point of attachment.
 - SHALL make permanent connections for the "stinger" to the tails of the entrance wires at the weatherhead.
 - SHALL install a 5ft long by 3/4 inch diameter Schedule 40 PVC conduit flush with the bottom of the CTS pole, permanently capped at the bottom, a removable cap at the top, and securely strapped to the pole with adequate spacing to allow for easy removal of the top cap for depth inspection.
 - Backfill SHALL be tamped to 90% compaction.
11. Meter socket requirements:
 - Meter socket SHALL be ringed type.
 - Meter clips SHALL be:
 - a) Free of any contaminants.
 - b) Free of any corrosion or damage.
 - c) Aligned in a true vertical position.
 - d) Provided with the proper spring tension to make positive connection with the meter stabs.
 - Insulating components SHALL be free of all contaminants and damage.

**CUSTOMER-OWNED PERMANENT/TEMPORARY WOOD SERVICE POLE
200 AMPERES MAXIMUM, 0-600 VOLTS**

NOTES:

- The pole shall be a new, self-supporting, fully-treated round pole with a minimum length of 25 feet and a minimum diameter at the top of 5 inches.

Note: Used poles are not acceptable.

- Service drop conductors, service drop attachment bracket and the meter shall be furnished and installed by the Department - all other equipment shall be furnished and installed by the contractor.
- Risers shall be 3/4-inch minimum polyvinyl Chloride (PVC) schedule 40 or metallic conduit and shall be securely attached to the pole.
- Floodlights, signs, ropes, and other similar equipment shall not be attached to the pole.
- The pole shall be located:
 - At least 10 feet from the Department service pole and, whenever practicable, at least 10 feet laterally from the center of the pole line but not more than 150 feet from the Department's servicing pole.
 - So that the ground clearance, buildings and other obstructions shall not reduce the service drop height below the required minimum clearances specified on pages 7-4 to 7-9.

Note: Consult with the area service planning office to determine the location of the attachment bracket on the pole required to meet the specified clearances.

- For permanent service applications, a safety-socket meter panel is required for all commercial services. For temporary service applications, a residential meter socket may be used for a 125-ampere, single-phase service - a safety-socket meter panel is required for all others.

Note: The service equipment short-circuit duty rating must meet or exceed the Department's fault current value for the installation.

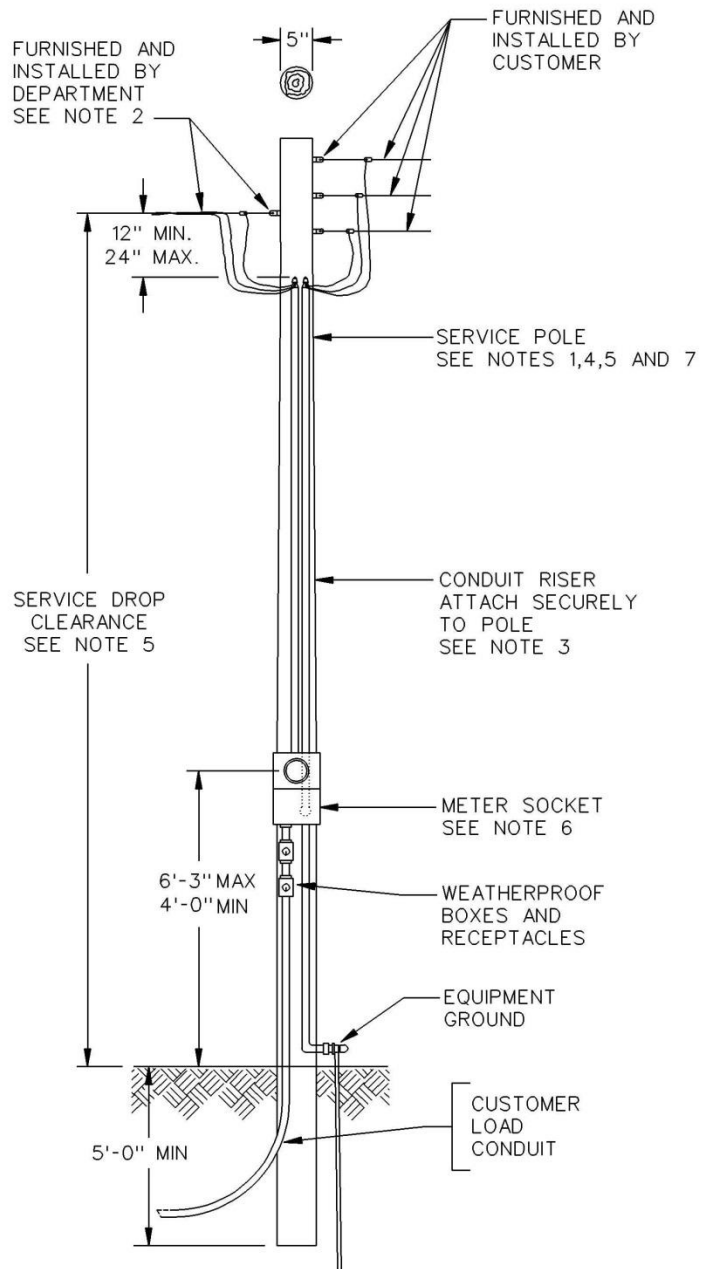

CUSTOMER-OWNED TEMPORARY WOOD SERVICE POLE (Cont.)

7. The numeric portion of the street address shall be provided on the pole on the side facing the street or drivable surface. Plastic or metallic numbers of the type used for house addresses are acceptable.
8. Service equipment and receptacles shall be weatherproof, rated for the load to be served and adequately bonded and grounded.
9. Additional references:
 - a. For safety-socket meter panel details, see pages 2-24 and 2-26.
 - b. Engineering offices and telephone numbers, see page 1-4.

**CUSTOMER-OWNED PERMANENT/TEMPORARY METAL SERVICE POLE
200 AMPERES MAXIMUM, 0-600 VOLTS**

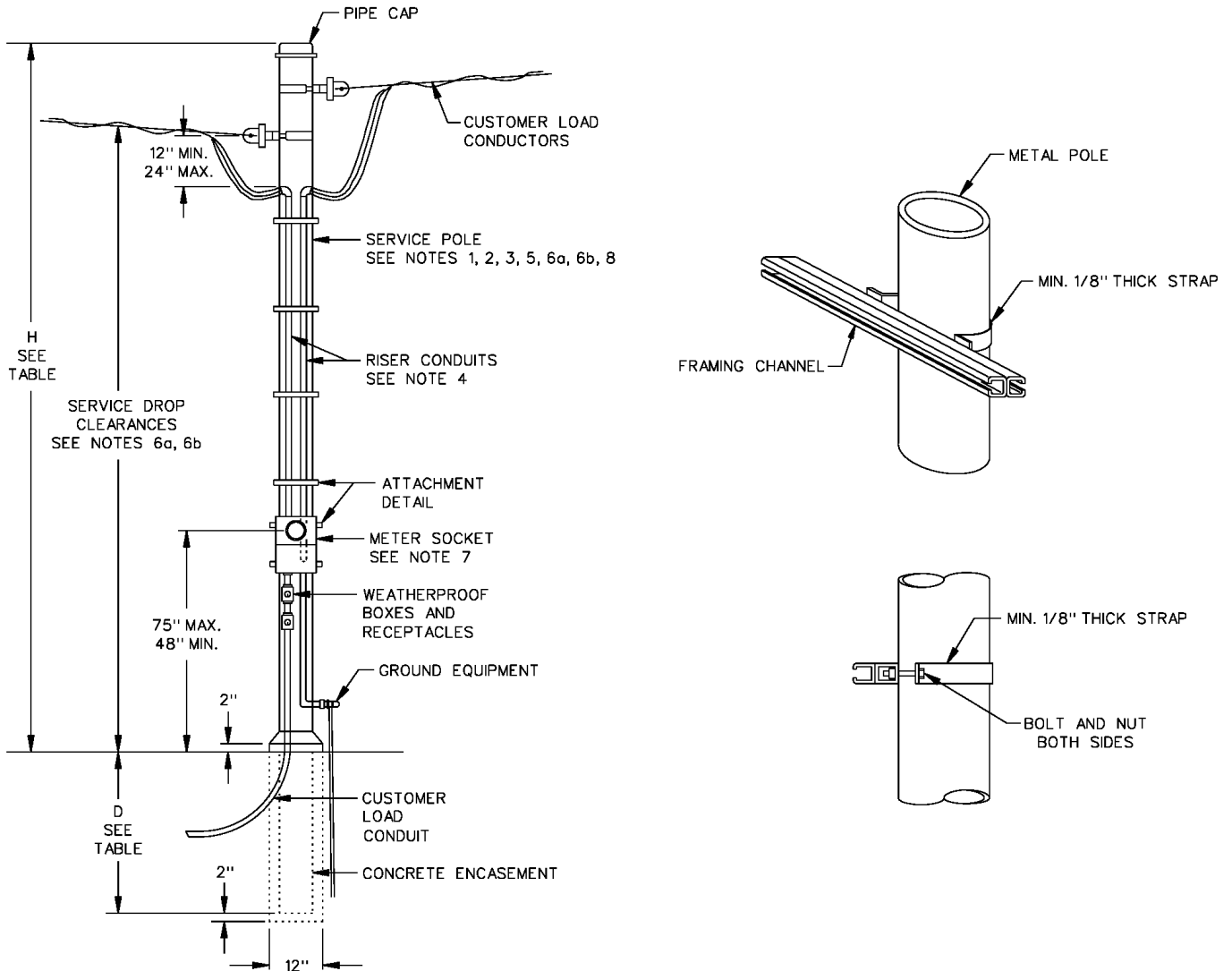

NOTES:

1. The service pole shall be constructed of a continuous, unbroken length of pipe provided with a pipe cap. The pipe shall be hot-dipped galvanized and threaded for attachment of the pipe cap. Acceptable grades for metal pipe are ASTM-A-53 (Type E or S), ASTM-A-500 and ASTM-A-501. Minimum pipe sizes shall conform to the following table:

(H) MINIMUM POLE HEIGHT ABOVE GROUND (FEET)*	(D) MINIMUM POLE DEPTH BELOW GROUND (FEET)	SCHEDULE 40 (STANDARD)	SCHEDULE 80 (EXTRA STRONG)
15	4	4" (GRADE B)	4" (GRADE A)
20	4-1/2	5" (GRADE B)	4" (GRADE A)
25	5	5" (GRADE B)	5" (GRADE A)

* Required pole height is based on the location of the point of attachment. See note 6b.

CUSTOMER-OWNED PERMANENT/TEMPORARY METAL SERVICE POLE (Cont.)

2. Attachments to metal poles shall be made with devices that will not affect the strength or integrity of the pole (see attachment detail). Drilling or welding are not acceptable.
3. The Department will furnish the attachment bracket and furnish and install the service drop conductors and meter. The customer shall install the attachment bracket and shall furnish and install the pole and all other equipment.
4. Riser conduits shall be 3/4-inch minimum polyvinyl Chloride (PVC) schedule 40 or metallic conduit. Metallic riser conduits are not required to be covered as long as the metal pole is effectively grounded and the metallic conduits are bonded to the pole. If a protective covering is required, consult the Department.
5. Floodlights, signs, ropes, and other similar equipment shall not be attached to the pole.
6. The pole shall be located:
 - a. At least 10 feet from the Department service pole and, whenever practicable, at least 10 feet laterally from the center of the pole line but not more than 150 feet from the Department's servicing pole.
 - b. So that the ground clearance, buildings and other obstructions shall not reduce the service drop height below the required minimum clearances specified on pages 7-4 to 7-9.

Note: Consult with the area service planning office to determine the location of the attachment bracket on the pole required to meet the specified clearances.
7. For permanent service applications, a safety-socket meter panel is required for all commercial services. For temporary service applications, a residential meter socket may be used for a 125-ampere, single-phase service - a safety-socket meter panel is required for all others.

Note: The service equipment short-circuit duty rating must meet or exceed the Department's fault current value for the installation.
8. The numeric portion of the street address shall be provided on the pole on the side facing the street or drivable surface. Plastic or metallic numbers of the type used for house addresses are acceptable.
9. Additional references:
 - a. For safety-socket meter panel details, see pages 2-24 and 2-26.
 - b. Engineering offices and telephone numbers, see page 1-4.

**CUSTOMER-OWNED PERMANENT/TEMPORARY SERVICE POLE WITH PEDESTAL
200 AMPERES MAXIMUM, 0-600 VOLTS**

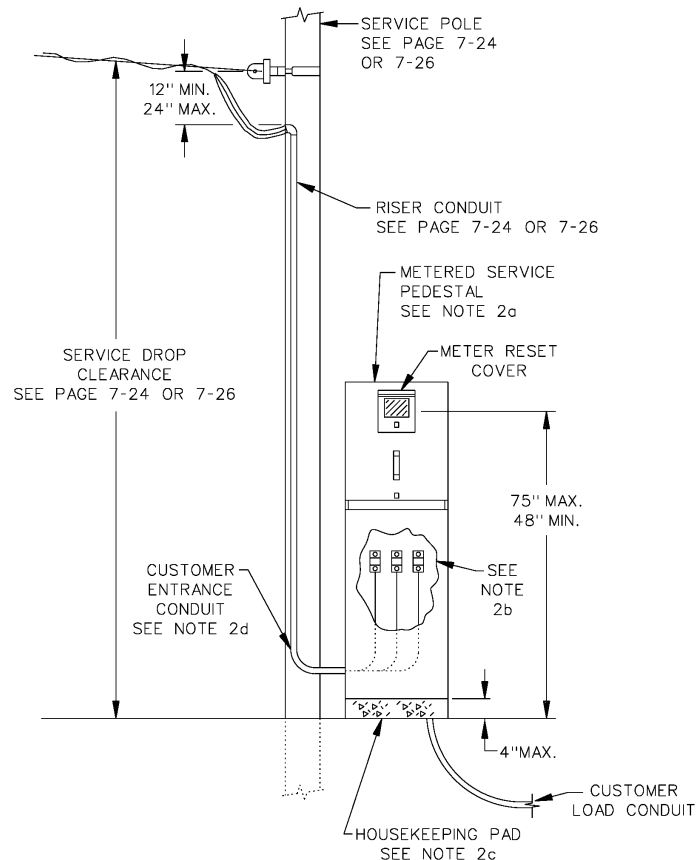

1. For wood or metal customer-owned service pole details, see pages 7-24 to 7-27.
2. For metered service pedestal in used conjunction with customer-owned service poles:
 - a. A commercial service and meter pedestal is required for all applications. The total service capacity is limited to 200 amperes. For dual-socket pedestal designs, the ampacity of each service disconnect (meter switch) shall not exceed 100 amperes.
 - b. A permanent sign shall be provided on the service entrance pull box cover reading:
"Wires in this Pull Box are the Responsibility of the Customer to Provide and Maintain"
 - c. The pedestal shall be mounted on a substantial concrete foundation.
 - d. Service entrance conduit riser and conductors shall enter the side of the pedestal's incoming pull box, be continuous and free of junction boxes and condulets.
3. Additional references:
 - a. For safety-socket meter panel details, see pages 2-24 and 2-26.
 - b. For commercial service and meter pedestals, see page 2-44, 2-45 and 2-46.
 - c. Engineering offices and telephone numbers, see page 1-4.

CONTENTS

	<u>PAGE</u>
A. Introduction	8-2
B. Data Required for Design	8-2
C. Electric Rates	8-3
D. Interconnection Agreements	8-3
E. Interconnection Costs	8-3
F. Transformer Requirements	8-3
G. Operating Requirements	8-4
H. Metering	8-4
Performance	8-4
Feed in Tariff	8-5
Switchboard Approval	8-5
I. Inspections	8-5
J. Liability	8-5
K. Disconnection of the Customer's Energy Sources	8-5
General	8-5
Notification	8-5
L. Utility Disconnecting Means	8-6
General	8-6
Access	8-7
M. Signs and Labels	8-7
N. Protective Schemes	8-7
O. Telemetry	8-9
P. Maintenance	8-9
Q. Records	8-9
R. Specifications	8-10
S. Testing and Evaluation	8-10
T. Generators and Generating Systems	8-10
U. Inverters	8-11
V. Battery Backup Systems	8-12
W. Battery Peak Shaving Systems	8-13
X. Battery Energy Storage Systems (BESS)	8-13
Illustrations:	
Typical Interconnection Arrangements	8-15
Notes	8-40

A. INTRODUCTION

1. This section is intended to assist Los Angeles Department of Water and Power (Department) customers in the design and evaluation of utility interconnections for customer-owned parallel-generation, backup and energy storage systems.
2. The Solar Incentive process has been separated from the solar interconnection process. For more information regarding available solar programs visit www.ladwp.com/solar.
3. The interconnection of customer-owned parallel-generation requires the following before any construction may begin:
 - a. **An Interconnection Agreement (IA):** See **TYPICAL TIME-LINES FOR PARALLEL-GENERATION INSTALLATIONS**, pages 1-16 and 1-17 for contact information and **INTERCONNECTION AGREEMENTS**, page 8-3 for details.
 - b. **A Generation Interconnection Study:** For aggregate parallel energy source capacities greater than 30kW, depending on available electric system (grid) capacity and line loading, a generation interconnection study shall be required to determine if the Department will need to install additional protective equipment, perform system modifications or upgrades at the customer's expense. The typical timeline for the generation interconnection study is 2-4 weeks. If the proposed aggregate parallel energy source is greater than the 15% of the peak line loading or 100% of the minimum line loading, dependent on generation system topology, a supplemental study shall be performed. The typical timeline for the supplemental study is 2-4 weeks. If the proposed generation system fails the supplemental study a detailed study shall be required. The typical timeline for the detailed study is 4-6 weeks.

Note: An interconnection study may result in lower capacity limitations than the maximum limits established in **PROTECTIVE SCHEMES**, page 8-7. Regardless of the number of supply points, these capacity limitations apply to the entire customer premises, see Glossary for definition of *Premises*.
 - c. **A Service Commitment:** The Department will determine the method of interconnection and transmit requirements to the customer in writing after appropriate engineering deposits and customer submittals have been received by the Department. See **DATA REQUIRED FOR DESIGN**, page 8-2.

B. DATA REQUIRED FOR DESIGN

1. When considering the installation of a parallel-generation and/or storage facility, customers must contact the Department as soon as possible so that:
 - a. The Department's Service Planners can work with the customer to establish an acceptable interconnection scheme for the customer's facility.
 - b. Customers may avoid unnecessary expenses and delays in service caused by assuming deficient interconnection schemes and equipment requirements.
2. At the time of initial contact, or as soon as possible, customers should provide the Department with the following information so that the Department may assist the customer in finalizing the customer's plans:
 - a. Electrical plans including load schedules, single-line diagrams, *Service Planning Information form* (see pages 1-19 and 1-20), and *Supplemental Battery Energy Storage System Data sheet* (if applicable).
 - b. Plot and site development plans showing generator, AC disconnect, metering equipment locations and Department access to generator, AC disconnect and meter equipment locations.
 - c. Energy source information:
 - (1) Maximum kilowatt rating
 - (2) Nominal voltage output
 - (3) Voltage regulation
 - (4) Maximum fault current contribution

B. DATA REQUIRED FOR DESIGN (Cont.)

- d. Protective system information:
 - (1) Protective system plan
 - (2) Manufacturer's data sheets and maintenance requirements for protective equipment
 - (3) Any additional information required by the Department
- 3. Upon receiving the requested information and engineering fees, the Department will provide customer requirements drawings and Department construction drawings as needed. Customer requirement drawings provide the customer with the information necessary to construct the interconnection facilities for the transformers, protective devices, meters and other necessary equipment that will be installed by the Department.

C. ELECTRIC RATES

Rates for the sale or exchange of electrical energy between the Department and the customer shall be in accordance with the established rates as specified in the effective Rate Ordinance(s) of the Department or by contract.

D. INTERCONNECTION AGREEMENTS (IA)

- 1. Customers are required to complete a Standard Offer Interconnection Agreement (Agreement) with the Department before the generating and/or storage facility may be interconnected to the Department's electric system.
- 2. Customers seeking to interconnect a new Electrical Generation Facility associated with service according to a Customer Generation (CG) rate shall be required to complete the *Declaration of Ownership of Electrical Generation Facility under a CG Rate* form.
- 3. The Department normally uses a Standard Offer contract for Agreements. However, if the Standard Offer is not suitable for the needs of the generating and/or storage facility, the customer may request the Department to consider a separate nonstandard Agreement.

E. INTERCONNECTION COSTS

Customers are required to reimburse the Department for all expenses associated with completing the interconnection of the customer's parallel-generation facilities including, but not limited to, extensions or modifications to the Department's electric system and related facilities and construction costs.

F. TRANSFORMER REQUIREMENTS

- 1. Energy sources rated less than 500kW may be connected on the secondary side of Department-owned transformers supplied from the 4800-volt electric system.
- 2. Energy sources rated 500-750kW may be required to be connected on the secondary side of dedicated Department-owned transformers supplied from the 34,500-volt electric system.
- 3. Energy sources rated over 750kW shall be required to be connected on the secondary side of dedicated Department-owned transformers supplied from the 34,500-volt electric system. Transformers shall be sized to supply the complete installation and will serve no other customer. Secondary distribution may be provided at the most convenient serving voltage for the customer.
- 4. Feed-In-Tariff (FiT) solar energy source(s) rated 1,000kW and above may be connected to the secondary side of Customer-owned transformers supplied from the 34,500-volt electric system. In these cases, the generation meter shall be located between the Customer-owned transformer and Department-owned system protection equipment. The metering equipment shall have a service class of 34,500-volts, Three-Phase, Three-Wire. For additional information, see pages 4-21 through 4-36.
- 5. The Department may require that the Department-owned transformers used to supply the customer's electric system be sized (i.e., kVA rating) equal to, or greater than, the customer's total generator capacity.
- 6. See **TRANSFORMER INSTALLATIONS ON THE CUSTOMER'S PREMISES** on page 1-33 for additional information.

G. OPERATING REQUIREMENTS

1. Customers are required to operate customer owned generating and storage facilities, whether permanent or temporary, in accordance with the Agreement, The Department's *Electric Service Requirements*, Rules, Rate Schedules and all other applicable Codes and Ordinances.
2. Customers shall not:
 - a. Energize an un-energized electric line or transformer.
 - b. Reconnect the energy source after a protective device trip unless the customer's electric system is energized by the Department's electric system by the Department, or unless the customer's electric system is isolated from the Department's electric system by the Department.

Note: Synchronous generators are capable of maintaining a distribution system energized even after the line protective device has opened and separated (relayed) the line from the Department's electric system. Since the Department uses automatic reclosing schemes to energize relayed lines after a short time delay, customer-owned equipment or Department-owned equipment may be damaged if power is restored to a line that is already energized by the customer's generator(s).

These operating and protective requirements have been established to protect the health and well-being of the public and utility workers from malfunctions in Department or customer equipment.

H. METERING

1. Customers shall provide Department approved metering arrangements for the installation of Department-owned generation and generation performance (performance) meters to measure the energy into, or out of, the installation at the interconnection point and at the energy source(s) output, respectively.

Exception: Provisions for a Department owned performance meter are no longer required for solar or wind generating systems with an aggregate capacity of 30kW or less.
2. All metering equipment drawings must be submitted to, and approved by, the Department service planner before the customer installs any equipment.
3. The performance meter as specified in these requirements is intended to measure the total output of the customer's generating system. No customer load is permitted on the generating system side of the meter.

Exception: Optional customer installed device(s) used to monitor system performance are permitted and are subject to the following conditions:

 - (1) Device(s) shall be co-located on the same side of the AC disconnect switch as its source of power.
 - (2) A device(s) power source wiring shall not bypass or defeat any AC disconnect switch.
 - (3) A device(s) power source and low voltage data circuits shall not enter or pass through any utility sealed section.
 - (4) Total device load shall not exceed 100 Watts.
4. Whether the service connection is overhead or underground:
 - a. The **line side** (top of meter) of the Department Revenue meter used for billing shall be connected to **Department side**, and the **load side** (bottom of meter) shall be connected to the **customer side (the generation contribution side)**.
 - b. The connections of the performance meter are opposite to those of the revenue meter. The **generation contribution side** is connected to the **line side** (top of meter) and the **Department side** is connected to the **load side** (bottom of meter). Refer to drawings on pages 8-16 to 8-34.

H. METERING (Cont.)

- c. The service class of the performance meter shall match the output of the generation source as measured by one of the Department's standard metering configurations. See page 2-5 for standard meter configurations.
5. **Feed in Tariff (FiT) Generation** - Use of current transformers applies to transformer rated meter installations. In this case, the current transformer polarities shall be facing the **Department** grid. For a self-contained FiT meter, the delivery direction for purpose of metering shall be from the **Department** grid to the **line side** (top of meter), and the customer's FiT from the **load side** (bottom of meter). The Department shall specify the class of service available for interconnection. See pages 8-17 (figure 3) and 8-18 (figure 4) for additional information.
Note: FiT generation taps shall not be made in any utility sealed section or compartment unless approved by the Department.
6. **Performance Meter Switchboard Review** – Manufacturer's switchboard drawings shall be submitted to the Department when the performance meter (regardless of ampacity) and the utility disconnect are integrated into a single switchgear unit, see pages 3-3 and 4-2, **Manufacturer's Drawings for Approval**.

I. INSPECTIONS

The Department requires that all conditions specified by these requirements be met and verified by the Department. In addition, an approval from the permitting agency for portions of the wiring and electrical equipment under their jurisdiction is required before the Department will establish the interconnection.

J. LIABILITY

1. Customers are responsible for damage caused to Department-owned equipment or other customers served from the Department's electric lines as a result of mis-operation or malfunction of the customer's energy source system.
2. The Department does not assume any responsibility for the protection of the customer's energy source(s) or any other portion of the customer's electrical system. The customer is fully responsible for protecting the customer's system so that faults or other disturbances on the Department's system do not cause damage to the customer's equipment.

K. DISCONNECTION OF CUSTOMER'S ENERGY SOURCES**1. GENERAL**

In compliance with the Department's *Rules Governing Water and Electric Service*, the Department reserves the right to disconnect the customer's energy source(s) from the Department's electric system:

- a. When the customer's energy source is adversely affecting the Department's electric system or other customer's supplied from the Department's electric system.
- b. When the customer-installed protective system has been defeated or not properly maintained, (lack of proper records is considered to be non-maintenance).
- c. If the customer denies access to the Department to the generating facility or to required maintenance and operating records.
- d. Under emergency conditions as determined by the Department.

2. NOTIFICATION

- a. **Under non-emergency conditions**, generally a notice of disconnection will be provided in writing as follows:
 - (1) For energy sources with an aggregate capacity of less than 500kW, the Department will endeavor to provide notification 72 hours in advance of the scheduled disconnection.
 - (2) For energy sources with an aggregate capacity of 500kW or greater, the Department will provide notification 72 hours in advance of the scheduled disconnection.

Date: 05-02-24

DESIGN GUIDE FOR CUSTOMER-OWNED PARALLEL GENERATING SYSTEMS

K. DISCONNECTION OF CUSTOMER'S ENERGY SOURCES (Cont.)

- b. **Under emergency conditions**, the Department reserves the right to disconnect the customer's energy source(s) without notification.
- c. If the customer-installed protective system becomes inoperative, the customer shall disconnect the energy source(s) from the Department's electric system and immediately notify the Department. When the protective system problems have been corrected, the customer shall request the Department for permission to reconnect the customer generation system.

L. UTILITY DISCONNECTING MEANS**1. GENERAL**

- a. Customers shall furnish, install and maintain circuit disconnect switches as required by State or National Electric Code and the Department to isolate the customer's parallel generator, generating and/or energy storage system from the Department's electric system. In general, a parallel generator AC disconnect switch and a generator circuit disconnect switch will be required for all synchronous generating systems, while only a parallel generator AC disconnect switch will be required for induction and inverter-based parallel generating systems. In general, an additional AC disconnect switch shall be required for energy storage.

Note: A parallel energy source AC disconnect switch shall not isolate a customer's load panel.

- b. The Department AC Disconnect Switch shall be a safety switch with a readily verifiable visual air gap to assure positive circuit disconnect and shall be lockable in the open (off) position with a Department standard padlock having a 5/16-inch lock shaft and a 1-inch locking clearance.

Note: A disconnect or circuit breaker with rack-out capability **shall not** be used to provide a readily verifiable visual air gap.

- c. AC disconnect switches shall have the line side of the disconnect switch, that is the fixed portion of the switch connected to the Department's power system. The load side of the switch, that is the movable portion of the switch (the blades) shall be connected to the side of the customer's parallel-generation contribution. The blade side of the switch shall contain the fuse, and the fuse shall be "cold sequence" so the fuse shall be de-energized from the utility source for safety.

Note: Safety switches shall have a viewing window to allow verification of the open switch condition without exposing the Department's personnel to energized bus. The viewing window shall be located on center no higher than 68 inches above the level standing and working space. Removing customer-owned fuses shall not be permitted as a means of providing an air gap.

Exception: Unless otherwise requested by the Department, a viewing window is not required for wall mounted safety switches if a visual air gap may be verified by way of a hinged cover, the potential is less than 600 volts, and where the maximum short-circuit at the AC disconnect is 22,000 amperes or less.

- d. Six or more AC disconnect switches connected to any single service point shall be approved by a Department engineer and may be limited by the City of Los Angeles Department of Building and Safety, or other Authority Having Jurisdiction (AHJ).
- e. A dedicated AC utility disconnect may not be required for inverter-based PV systems with total combined aggregate capacities up to and including 30 kW AC per premises. A dedicated AC utility disconnect may not be required for inverter-based Battery Energy Storage Systems with total combined capacities up to and including 30 kW AC per premises. This includes single-phase and three-phase systems. For example, a 30kW photovoltaic system could be installed without a utility disconnect switch at the same premises as a 30kW battery energy storage system without a utility disconnect switch, provided:

- (1) The service supply voltage is less than 600 Volts and,
- (2) The service main disconnect controls all power flow registered by the meter and,
- (3) Energy sources are not connected to the meter panel through a line side tap and,

L. UTILITY DISCONNECTING MEANS (Cont.)

- (4) The combination meter panel is of the 'self-contained type' commercial safety socket, residential class 320 or less and,
- (5) The service consists of no more than six self-contained type meters per premises and,
- (6) The service is not fed from the Department's 34.5kV sub-transmission system.

Note: Services that are converted to the Department's 34.5kV sub-transmission system or exceed the limits given above in the future shall require AC utility disconnects be installed for all existing energy sources at the customer's expense.

Note: The Department may need to remove the revenue meter to disconnect the customer's energy sources when required under section page 8-5(K).

2. ACCESS

Switches used to disconnect the energy source shall be accessible under all conditions and at all times to Department personnel. This may require disconnect switches to be located in a publicly accessible area or be provided with an interlock system to gain access to an installation in a security-controlled area.

Exception: Parallel generating systems with an aggregated output capacity of 100kW or less per property or premises as determined by the Department. In these cases, performance meters and AC disconnect switches must be readily accessible and located on the exterior wall of a building or other approved permanent structure, in an approved meter room on the ground floor or first basement parking level or such other locations as the Department may designate.

M. SIGNS AND LABELS

1. **The customer shall provide and install the following signs** as directed by the Department:
 - a. A sign at the main service (meter) panel location identifying each energy source AC disconnect location.
 - b. A sign at each Department specified energy source AC disconnect identifying the main service location.
 - c. A sign on each personnel entrance door for Customer Stations.
 - d. Any other signs deemed necessary by the Department to provide energy source AC disconnect location information.
2. **The customer shall provide a sign to be installed by the Department** for each Department-owned pad-mount transformer and Customer Station connected to the customer's parallel-generation system.
3. **The customer shall provide and install the following diagrams** when required by the Department:
 - a. A single-line diagram located at the main service panel location. The diagram shall be approved by the Department and installed by the customer as directed by the Department.
 - b. A plot plan located at the main service panel showing the location of the energy source AC disconnect(s). The plot plan shall be approved by the Department and installed by the customer as directed by the Department.

N. PROTECTIVE SCHEMES

1. Customer generating facilities shall be provided with protective schemes in order to ensure the security of the Department's electric system, security of other customers supplied from the Department's electric system and the safety of Department operating personnel.
2. In general, the Department will provide and install, at the customer's cost, required protective equipment. However, where mutually agreeable between the Department and the customer, the customer may provide and install, at the customer's cost, protective equipment as specified by the Department for:
 - a. Synchronous generation with an aggregate capacity of less than 300kVA (240kW) and induction generation less than 400kVA (320kW) when supplied from the Department's 4800-volt electric system.

N. PROTECTIVE SCHEMES (Cont.)

- b. Synchronous generation with an aggregate capacity of less than 400kVA (320kW) and induction generation less than 600kVA (480 kW) when supplied from the Department's 34,500-volt electric system.
- c. Inverter-based generation and/or export capable storage with an aggregate capacity of less than 1,000kW when supplied from any Department electric system.

Note: The values given above are the absolute limits for each individual type of generation or export capable storage per customer premises. Aggregation of different types may reduce the limits above and require the installation of additional protective equipment. The specific protective scheme required is subject to the Department's available distribution system capacity, see page 8-2 note A.3.b. for generation integration study requirements.

- 3. The Department will install ground fault protection (GFP) equipment, at the customer's cost, for customer generating and/or storage facilities with an aggregate capacity of 1,000kW or greater and interconnected with the Department's 34,500-volt electric system.

Note: The Department may require GFP for customer generation and/or storage facilities with an aggregate capacity of less than 1,000kW and interconnected with the Department's 34,500-volt electric system when the facilities are located in remote areas or whenever such protection, in the Department's judgment, is necessary.

- 4. The electrical rating (kW) of the customer's generating and/or storage facility will determine, in part, the configuration in operating characteristics and protection requirements for a customer's interconnection installation. Typical protection equipment requirements include, but are not limited to:
 - a. Under-voltage (Device 27) protection
 - b. Over-voltage (Device 59) protection
 - c. Under-frequency (Device 81U) protection
 - d. Over-frequency (Device 81O) protection
 - e. Tripping batteries, circuit breakers and battery chargers

Note: See **SPECIFICATIONS** on page 8-9i for additional information.

- 5. Customer's energy source circuit breakers must positively disconnect under all conditions. In most instances this will require the installation of a charger assisted, uninterruptible DC power source.
- 6. The Department reserves the right to review and approve any interconnection scheme involving customer initiation of the customer interconnecting breaker controls.
- 7. Protective equipment shall comply with IEEE1547-2018/2020a and be tested by the customer per IEEE1547.1-2020 prior to commissioning. Test reports shall be provided to the Department upon request.
- 8. Protective equipment shall be readily accessible to the Department for periodic inspection.
- 9. For inverter-based (1,000kW to 10,000kW), synchronous (greater than 320kW), or induction (greater than 480kW) aggregate capacity parallel generating and/or storage systems, the Department will provide additional protective equipment, at the customer's expense, including switchgear with a vacuum interrupter, all necessary remote control, communication and protective devices (relays), batteries, and battery charger. The customer shall provide and maintain a dedicated communication equipment, see **TELEMETRY**. The customer shall also provide 120 volt single-phase control power to the protection equipment, as specified by the Department.
- 10. For parallel generating installations with an aggregate capacity greater than 10,000kW, consult the Department for requirements.

O. TELEMETRY

1. When required by the Department (see **PROTECTIVE SCHEMES**), the customer shall provide all communications cabinets, network equipment, cables, connectors and house power as specified by the Department, see the Department's *Standard Telecom Requirements* guide. For projects located in the Owens Valley, consult the Department for specific requirements.
2. For installations with an aggregate capacity greater than 30kW, but less than 1,000kW, the Department may utilize the performance meter to provide continuous output information at the Department's Energy Control Center. This information shall include, but not be limited to:
 - a. Energy source voltage, current, watts, vars, and watt-hours.
3. When required by the Department (see **PROTECTIVE SCHEMES**), the customer shall pay for equipment with relay protection, real time metering, and SCADA at the generating facilities interconnection point to provide SCADA information, and remote control to the Department's Energy Control Center. This equipment will be specified and installed by the Department. The information shall include, but not be limited to:
 - a. Real time analog reads for the energy source: watts, vars, voltage, current, and watt-hours.
 - b. Status and alarm indication of each energy source synchronizing disconnect information (i.e., open or closed).
 - c. Control capability of the interconnection circuit breaker(s) (i.e. trip or close)

P. MAINTENANCE

1. Where the Department installs the protective equipment, the Department is responsible for maintaining such equipment. Where the customer installs the required protective equipment, the customer shall maintain such equipment and provide monthly maintenance of the tripping battery and the battery charger.
2. For customer parallel-generation installations with an aggregate capacity of 500kW or more, maintenance of the customer's energy source must be scheduled in advance to be compatible with the Department's electric system load requirements.

Q. RECORDS

1. Customers shall provide, upon request, accurate records of the customer's generating facility. Such records shall include but not be limited to:
 - a. Tripping batteries and battery chargers, where protective equipment is installed by the customer:
 - (1) Date and time of maintenance
 - (2) Description of maintenance performed
 - b. Each energy source:
 - (1) On-line and off-line times
 - (2) Generation output (kW)
 - (3) Maintenance outages
 - (4) Trip operations
 - (5) Any unusual events
2. The Department reserves the right to periodically review the customer's maintenance records for system analysis and to evaluate system disturbances.

Date: 05-02-24

DESIGN GUIDE FOR CUSTOMER-OWNED PARALLEL GENERATING SYSTEMS

R. SPECIFICATIONS

1. Customer generating facilities shall be constructed to meet the following specifications:
 - a. System frequency shall be 60 cycles per second (Hz).
 - b. Signal distortion shall be limited to 5-percent of the RMS value of the Department's serving voltage and 25-percent of the waveform.
 - c. Power factor of the customer's electric system shall be limited as follows:
 - (1) For parallel generating systems with an aggregate capacity of less than 1,000kW, the average monthly on-peak power factor shall not be less than 85-percent lagging.
 - (2) For generating systems with an aggregate capacity of 1,000kW or greater, the power factor shall not be less than 99.5-percent lagging or more than 99.5-percent leading.

Note: The Department will measure these specifications at the metering facility.
2. Protective equipment relays used to open and close generator circuit breakers shall operate with the following specifications:
 - a. Under-voltage (Device 27), 92 volts or lower with a maximum time delay of 2.0 seconds
 - b. Over-voltage (Device 59), 138 volts or more with a maximum time delay of 2.0 seconds
 - c. Under-frequency (Device 81U), 57 Hz or lower with a maximum time delay of 2.5 seconds
 - d. Over-frequency (Device 81O), 61 HZ or more with a maximum time delay of 2.5 seconds

S. TESTING AND EVALUATION

1. Customers shall test the generating facility before interconnecting with the Department's electric system and provide written certification to the Department that the generating facility meets the Department's specifications.
2. The Department reserves the right to test the customer's equipment before approving the connection to the Department's electric system and the right to monitor onsite operations of the equipment.
3. If the generating facility does not meet the Department's specifications, the Department may require the customer to disconnect the facility and make corrections or reimburse the Department for corrections as specified in the Agreement.
4. After the Department determines that the operation of an energy source will not be hazardous or impair the reliability of the Department's electric system, the Department will provide written permission to complete the interconnection
5. Periodic Interconnection Tests - Where the customer installs protective equipment, the customer shall have the equipment tested at two-year intervals by a Department approved testing agency at the customer's cost. It is the customer's responsibility to arrange for contracts and payments to the approved testing agency and to complete testing within the two-year interval (see **PROTECTIVE SCHEMES**).

T. GENERATORS AND GENERATING SYSTEMS

1. Parallel generating systems operated by customers shall be connected to the customer's electric system on the load side of the revenue meter at a permanent Department approved location.

Note: Parallel generators or generating systems **shall not be installed within any mobile home park** unless residential structures are individually metered, mounted to a permanent foundation system and given preliminary approval by the Department's Tract Design group, see page 1-4. Each proposed installation shall require Department engineering review and may be approved on a case-by-case basis only if the above conditions are met and the Department determines that there are adequate facilities to support the proposed generation.

T. GENERATORS AND GENERATING SYSTEMS (Cont.)

2. Parallel generating systems may be connected on either the line side or load side of the customer's service disconnecting means as allowed by the permitting agency or other Authority Having Jurisdiction (AHJ) but are subject to the following restrictions:
 - a. Parallel-generation circuit connections may not be made in, or accessed through, any sealed utility compartment.
Exception: Where metering equipment has been specifically designed and manufactured with a line side tap terminating in a section that is accessible to the customer, and has been labeled and certified by the manufacturer for the sole purpose of connecting parallel generating systems.
 - b. Generation circuit conduits and conductors shall not be routed through any sealed utility compartment.
Note: sealed utility compartments include terminating pull boxes and pull sections, metering compartments, and test-bypass compartments.
Caution: Existing service equipment may not have a suitable parallel-generation connection point on the line side of the customer's service over-current device and may require third party certification of any proposed connection location. Consult with LADBS or other applicable permitting agency regarding third party certification requirements.
3. Single-phase generation sources are limited to 30kW total capacity per premises unless dedicated on-site transformation is provided. Installations with individual single-phase inverters greater than 30kW shall use a three-phase interconnection system and balance the sources between the phases.
4. For synchronous generators, automatic synchronization is preferred. However, manual synchronization with relay supervision is acceptable.
5. Synchronous generators designed to be started as induction motors may not require synchronizing relays, but will not be permitted to start up if it results in detrimental effects to the Department's electric system.
6. Voltage regulation equipment must be provided on the customer's generator to maintain generation voltage to within normal Department limits.
7. Induction generator installations may require capacitors to correct the power factor. Protection schemes must be coordinated to ensure that the capacitors will always be disconnected before the induction generator is disconnected.
8. Generator installations rated 750kW or less may be required by the Department to meet conditions and specifications normally required for installations rated over 750kW. Safeguards that will be required and the degree of sophistication will depend on the type of equipment and the interconnection scheme.

U. INVERTERS

Inverters may be used in customer generation systems that are interconnected with the Department's Electric system (grid). An inverter shall:

1. Be permanently utility interactive at the point of interconnection to the grid.
Exception: Inverters may function in "off-grid" mode during a utility outage under the following circumstances:
 - a. The inverter supplies power to an outlet on the inverter unit that is accessible only to qualified service personnel per UL1741SA standards. Warning: Outlet circuit shall not be integrated with the buildings internal wiring system.
 - b. The inverter supplies power to charge a battery backup system to feed critical loads (See section V).
Hybrid inverters may be used, provided that any additional "off-grid" AC outputs are never connected in parallel with the Department's grid.

Date: 05-02-24

DESIGN GUIDE FOR CUSTOMER-OWNED PARALLEL GENERATING SYSTEMS

U. INVERTERS (Cont.)

Systems with battery storage may require additional testing to confirm that the battery system, with the utility side de-energized, provides power to the designated customer circuits only, and does not back feed into the main panel (into the Department's grid).

2. Be certified by a Nationally Recognized Testing Laboratory to fully comply with UL1741SA performance and grid safety standards. The Certificate of Compliance should state that this utility interactive inverter met all applicable requirements of current editions of UL1741SA and IEEE1547-2018/2020a, including testing conformance to IEEE1547.1-2020. Also, refer to sections R and S (pages 8-9 & 8-10) for specification, testing and evaluation requirements. All inverters shall be included in the California Energy Commission's (CEC) list.
3. Be accepted by the Department of Building and Safety, City of Los Angeles, or other Authority Having Jurisdiction (AHJ).
4. Have safeguards to prevent power flow into un-energized Department's electric system.
5. **Have the voltage output match the electrical characteristics of the service provided by the Department.** For example, a single-phase inverter shall not be connected to a three-phase service, and an inverter of one voltage class shall not be connected to a service of a different voltage class. See page 1-25 for available service classes.

Exception 1: Customer provides, at their expense, transformation between the performance meter and NET energy or generation meter to match the electrical characteristics of the service provided by the Department.

Exception 2: When connected to a three-phase service, three single-phase inverters may be used in lieu of a three-phase inverter, provided that the customer maintains IEEE1547-2018/2020a compliance by installing additional certified equipment to shut down all inverters in the event of a "loss or open phase" event and maintain a balanced condition when connected to a three-phase system.

6. Have an output that may be measured by a performance meter (see section H) conforming to one of the Department's standard meter configurations. See page 2-5 for standard meter configurations.
7. Operate as a current source rather than a voltage source; so that open-circuited inverter shall have an output of zero volts. It shall only produce power output when it is connected to an energized Electric Power System (EPS). The inverter's voltage output will not be independent from the Department's service supply voltage, but it will be synchronized with it in such a way as to produce a current and power flow from the Customer's parallel-generation into the Department's power system (grid).
8. Operate within the Department's acceptable service supply voltage ranges. See Acceptable Voltage Ranges, page 1-26 for additional information.
9. For the purposes of these requirements, be defined by its maximum continuous output power at unity power factor.
10. Include a Utility Settings Compliance report indicating conformance with the Department's UL1741SA *Smart Inverter Technical Requirements*. This report shall be submitted to the Department upon request.

V. Battery Backup Systems

Battery backup systems are used to provide emergency standby power to essential loads during a disturbance on the Department's electric system (grid), see pages 8-20 (figure 6) and 8-22 (figure 8). A battery backup system shall:

1. Be used to serve essential loads on the customer's premises, only.
2. Have safeguards to prevent a parallel connection with the Department's electric system such as an external automatic transfer switch (ATS), manual transfer switch, or double throw safety switch that is listed by a Nationally Recognized Testing Laboratory for this application (example: *UL 1008 standard for transfer switches*). See **EMERGENCY OR STAND-BY GENERATORS**, page 1-32 for additional information.

V. Battery Backup Systems (Cont.)

3. Be reviewed and approved by the Department before construction begins. Customer shall provide copies of the one-line diagrams and documentation describing modes of operation to the Department prior to start of construction. Review by the Department of Customer's specifications shall not be construed as confirming or endorsing the design, or as implying any warranty of safety or durability of the Customer facility. The Department shall not, by reason of review or failure to review, be responsible for strength, details of design, adequacy or capacity of the Customer facility or said equipment, nor shall the Department's acceptance be deemed to be an endorsement of the Customer facility.

NOTE: Batteries shall not be located in the meter room. See pages 5-9 and 5-10 for more information. Contact the Los Angeles Department of Building and Safety (LADBS) or other Authority Having Jurisdiction (AHJ) for specific code requirements.

W. Battery Peak Demand Shaving Systems

Battery peak demand shaving systems are used for energy demand management and are typically operated in parallel with the Department's electric system (grid), see page 8-21 (figure 7). A battery peak demand shaving system shall:

1. Be used to monitor and control the customer's peak energy usage, only.
2. Not have customer owned CT's, monitoring devices or wiring located in any Department sealed section.
3. Be utility interactive and certified by a Nationally Recognized Testing Laboratory to fully comply with IEEE1547-2018/2020a and UL1741SA or UL9540 for grid safety, see page 8-11.
4. Not be used with Department Generation or NET energy metering or allow for the export of energy to the Department's grid, see page 8-21 (figure 7).
5. Only be operated in parallel with the Department's transmission and distribution system for more than one second if Customer has on file with the Department the latest version of the Customer Interconnection Agreement provided by the Department to address safe parallel operation of customer-owned battery energy storage systems.
6. Be reviewed and approved by the Department before construction begins. Customer shall provide copies of the one-line diagrams and documentation describing modes of operation to the Department prior to start of construction. Review by the Department of Customer's specifications shall not be construed as confirming or endorsing the design, or as implying any warranty of safety or durability of the Customer facility. The Department shall not, by reason of review or failure to review, be responsible for strength, details of design, adequacy or capacity of the Customer facility or said equipment, nor shall the Department's acceptance be deemed to be an endorsement of the Customer facility.

NOTE: Batteries shall not be located in the meter room. See pages 5-9 and 5-10 for more information. Contact the Los Angeles Department of Building and Safety (LADBS) or other Authority Having Jurisdiction (AHJ) for specific code requirements.

X. Battery Energy Storage Systems (BESS)

Other battery energy storage systems are typically used to store energy for self-consumption and to provide emergency standby power to essential loads during a disturbance on the Department's electric grid, see pages 8-23 (figure 9) to 8-36 (figure 22) and 8-38 (figure 24). Storage systems of this type are operated in parallel with the Department's electric system (grid) and shall:

1. Not have customer owned CT's, monitoring devices or wiring located in any Department sealed section.
2. Be utility interactive and certified by a Nationally Recognized Testing Laboratory to fully comply with IEEE1547-2018/2020a and UL1741SA or UL9540 for grid safety, see page 8-11.

X. Battery Energy Storage Systems (Cont.)

3. Comply with the requirements for **BATTERY BACKUP SYSTEMS** when functioning in backup mode, see page 8-12.
4. Not export to the grid though Department NET energy metering unless exclusively charged by eligible renewable parallel-generation. See pages 8-29 (figure 15) and 8-30 (figure 16) for additional information.
5. Include power controls that prevent the inadvertent export of energy when required under note 4 of this section. Power control settings shall be securely adjustable by the manufacturer or other qualified electrical worker as designated by the manufacturer. The customer shall not have direct access to power control settings. A settings compliance report shall be provided to the Department upon request.
6. Be operated parallel with the Department's transmission and distribution system for more than one second if Customer has on file with the Department the latest version of the Customer Interconnection Agreement provided by the Department to address safe parallel operation of customer-owned battery energy storage systems.
7. Be programmed to operate only in a manner which is consistent with the Department's Electric Service Requirements, and may require distribution system upgrades as determined after Department review to accommodate the total size of the electrical generating facility and the maximum capacity of all battery energy storage systems.
8. Be reviewed and approved by the Department before construction begins. Customer shall provide copies of the one-line diagrams and documentation describing modes of operation to the Department prior to start of construction. Review by the Department of Customer's specifications shall not be construed as confirming or endorsing the design, or as implying any warranty of safety or durability of the Customer facility. The Department shall not, by reason of review or failure to review, be responsible for strength, details of design, adequacy or capacity of the Customer facility or said equipment, nor shall the Department's acceptance be deemed to be an endorsement of the Customer facility.
9. Not be operated if Customer fails to provide any information requested by the Department regarding the solar electrical generating facility that includes such battery energy storage system.

NOTE: Batteries shall not be located in the meter room. See pages 5-9 and 5-10 for more information. Contact the Los Angeles Department of Building and Safety (LADBS) or other Authority Having Jurisdiction (AHJ) for specific code requirements

10. Comply with the following codes/standards or its successors, if applicable:
 - a. UL 1741/1741SA, UL 1793, UL 1973, UL 9540, UL 9540A
 - b. IEEE 1547-2018/2020a, IEEE 1547.1-2020 , IEEE P2686, IEEE 519, IEEE 693
 - c. NFPA 1, NFPA 70, NFPA 70B, NFPA 855, NFPA 72
 - d. NEC 480, NEC 705, NEC 706
 - e. ANSI C84. 2006
 - f. CFC 1206, IFC-2018/2021
 - g. IEC 62933-5-2

**TYPICAL INTERCONNECTION ARRANGEMENT
SOLAR NET ENERGY METERING (30kW OR LESS)**

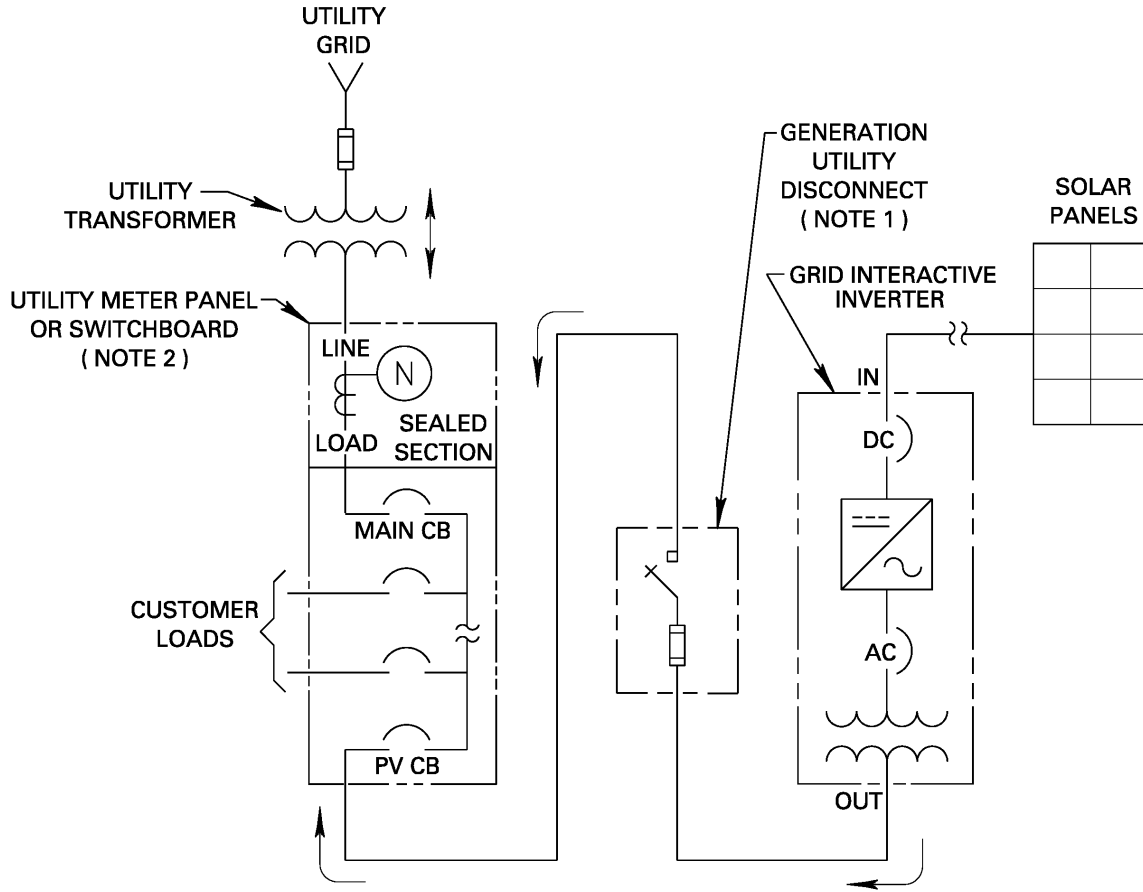

'N' - NET METER
 ←→ POWER FLOW

FIGURE 1

Note: This single line diagram has been simplified to illustrate the Department's interconnection requirements and does not necessarily represent all possible equipment arrangements. Contact the Los Angeles Department of Building and Safety (LADBS) or other Authority Having Jurisdiction (AHJ) for specific code requirements.

**TYPICAL INTERCONNECTION ARRANGEMENT
SOLAR NET ENERGY METERING (GREATER THAN 30kW)**

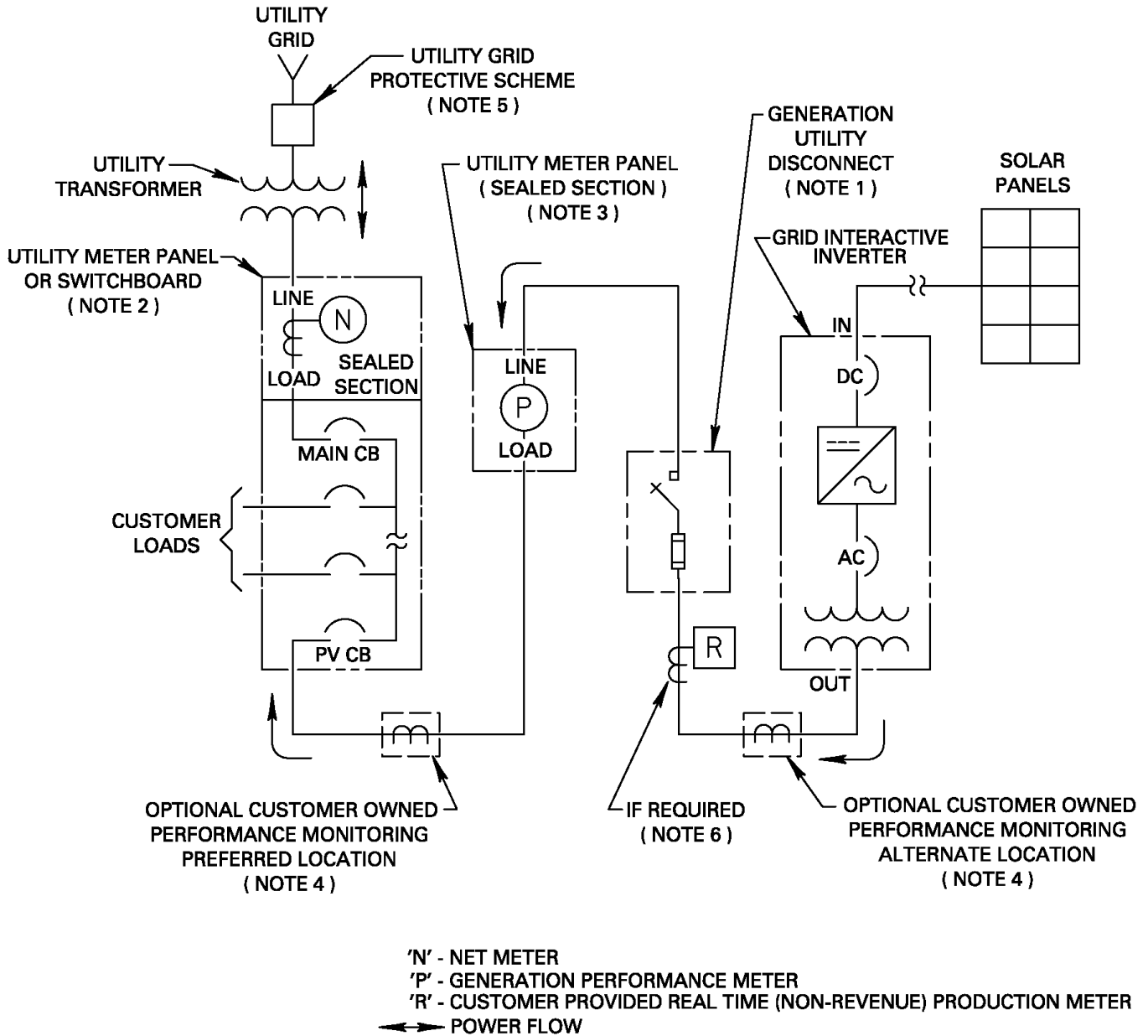

*Solar NET energy metering is not available for total system capacities of 1MW and above.

FIGURE 2

Note: This single line diagram has been simplified to illustrate the Department's interconnection requirements and does not necessarily represent all possible equipment arrangements. Contact the Los Angeles Department of Building and Safety (LADBS) or other Authority Having Jurisdiction (AHJ) for specific code requirements.

**TYPICAL INTERCONNECTION ARRANGEMENT
SOLAR FEED IN TARIFF (FIT) GENERATION METERING
(UTILITY-OWNED TRANSFORMER)**

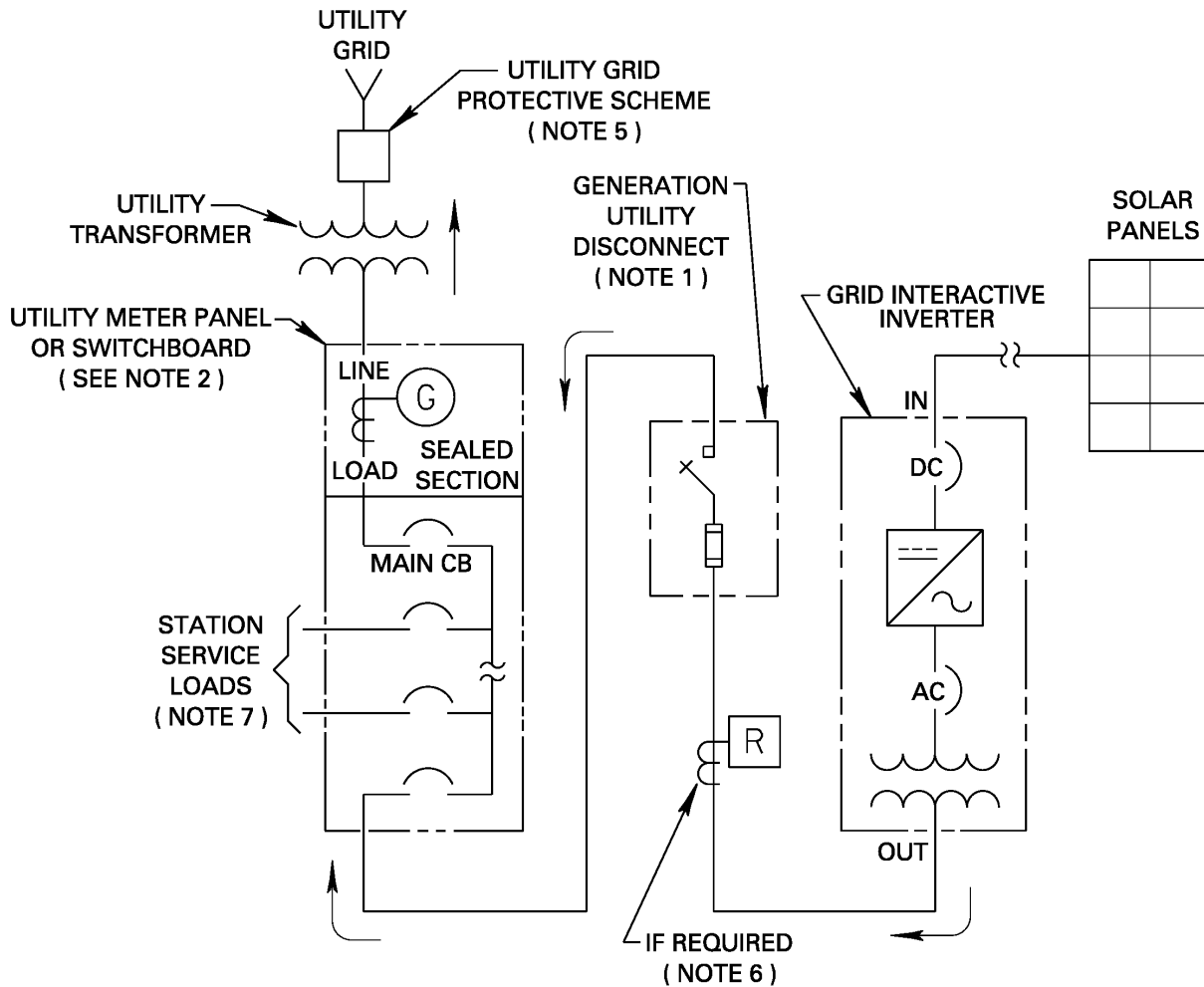

'G' - GENERATION INTERCHANGE METER
'R' - CUSTOMER PROVIDED REAL TIME (NON-REVENUE) PRODUCTION METER
↔ POWER FLOW

FIGURE 3

Note: This single line diagram has been simplified to illustrate the Department's interconnection requirements and does not necessarily represent all possible equipment arrangements. Contact the Los Angeles Department of Building and Safety (LADBS) or other Authority Having Jurisdiction (AHJ) for specific code requirements.

TYPICAL INTERCONNECTION ARRANGEMENT
SOLAR FEED IN TARIFF (FIT) GENERATION METERING
(CUSTOMER-OWNED TRANSFORMER)

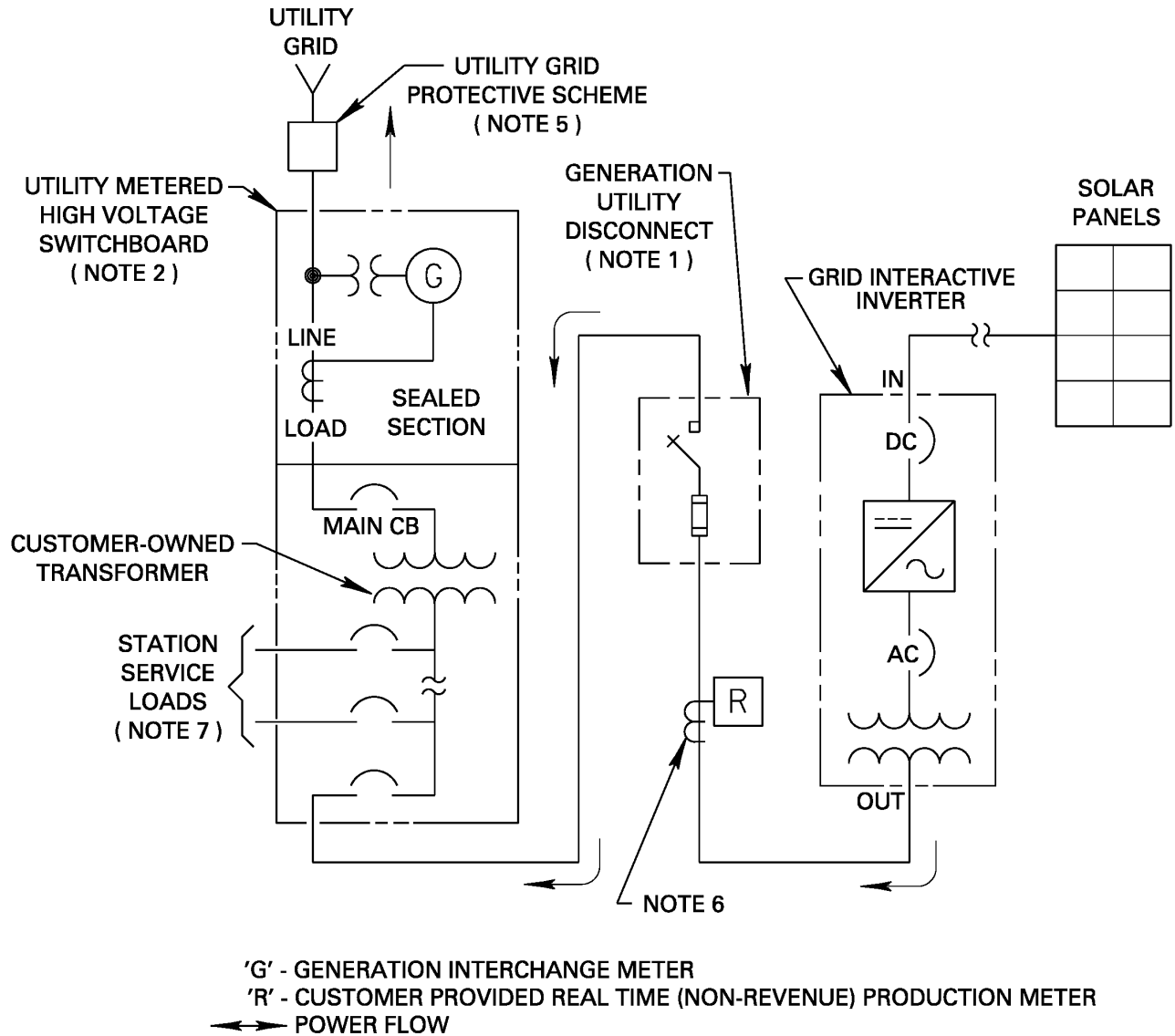

FIGURE 4

Note: This single line diagram has been simplified to illustrate the Department's interconnection requirements and does not necessarily represent all possible equipment arrangements. Contact the Los Angeles Department of Building and Safety (LADBS) or other Authority Having Jurisdiction (AHJ) for specific code requirements.

**TYPICAL INTERCONNECTION ARRANGEMENT
SYNCHRONOUS GENERATION METERING**

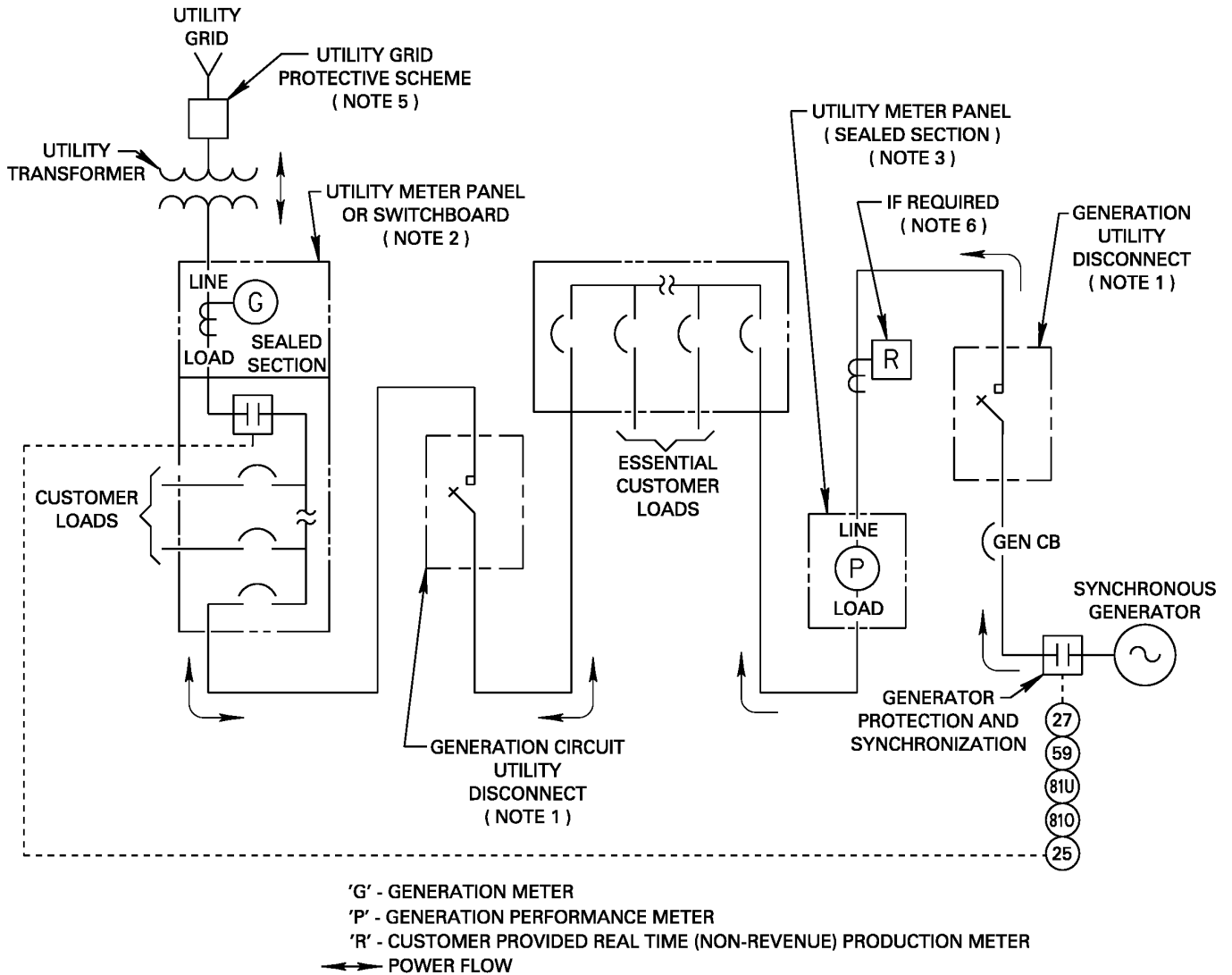

FIGURE 5

Note: This single line diagram has been simplified to illustrate the Department's interconnection requirements and does not necessarily represent all possible equipment arrangements. Contact the Los Angeles Department of Building and Safety (LADBS) or other Authority Having Jurisdiction (AHJ) for specific code requirements.

TYPICAL INTERCONNECTION ARRANGEMENT
BATTERY BACKUP

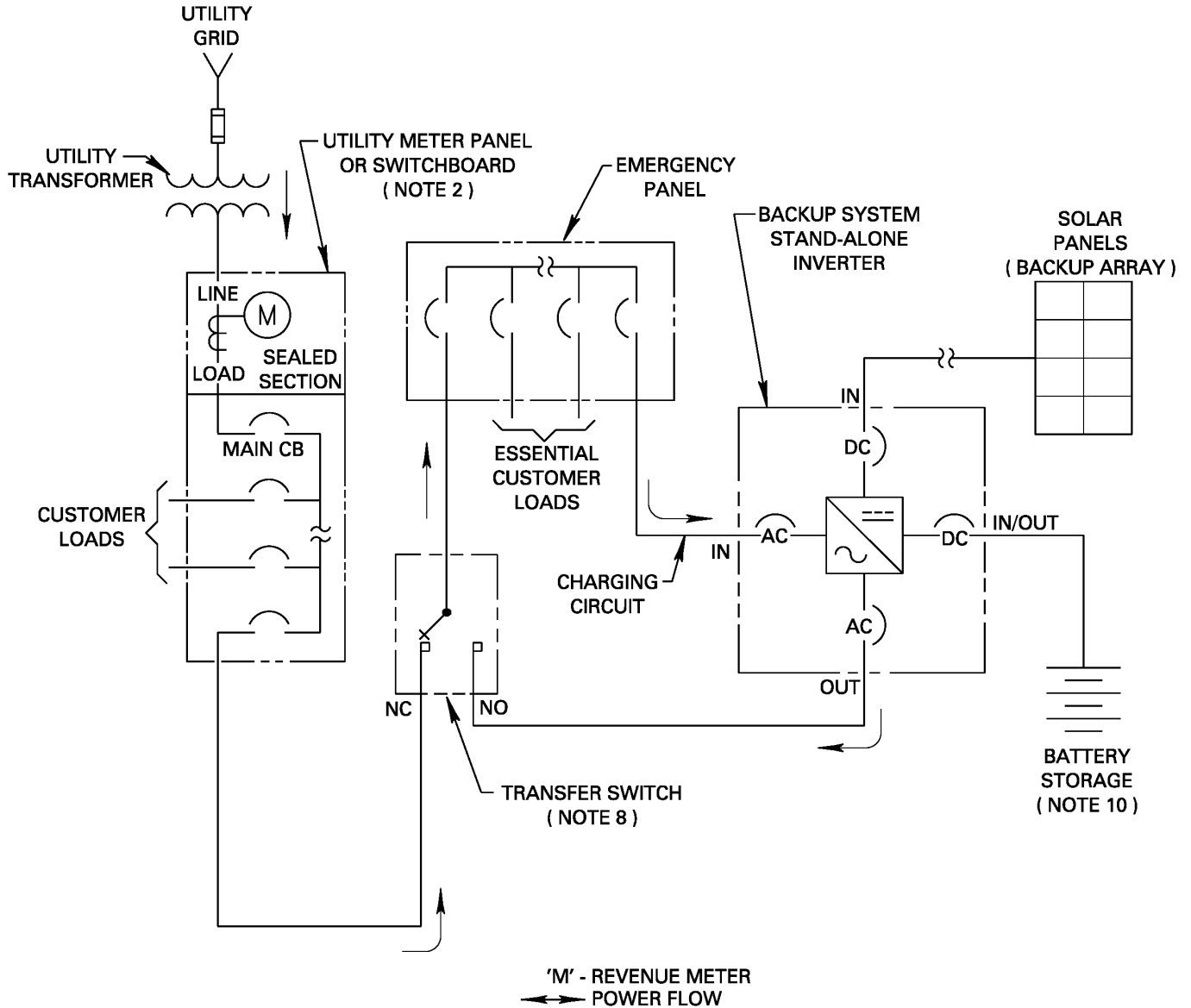

FIGURE 6

Note: This single line diagram has been simplified to illustrate the Department's interconnection requirements and does not necessarily represent all possible equipment arrangements. Contact the Los Angeles Department of Building and Safety (LADBS) or other Authority Having Jurisdiction (AHJ) for specific code requirements.

**TYPICAL INTERCONNECTION ARRANGEMENT
DEDICATED PEAK DEMAND SHAVING SYSTEM**

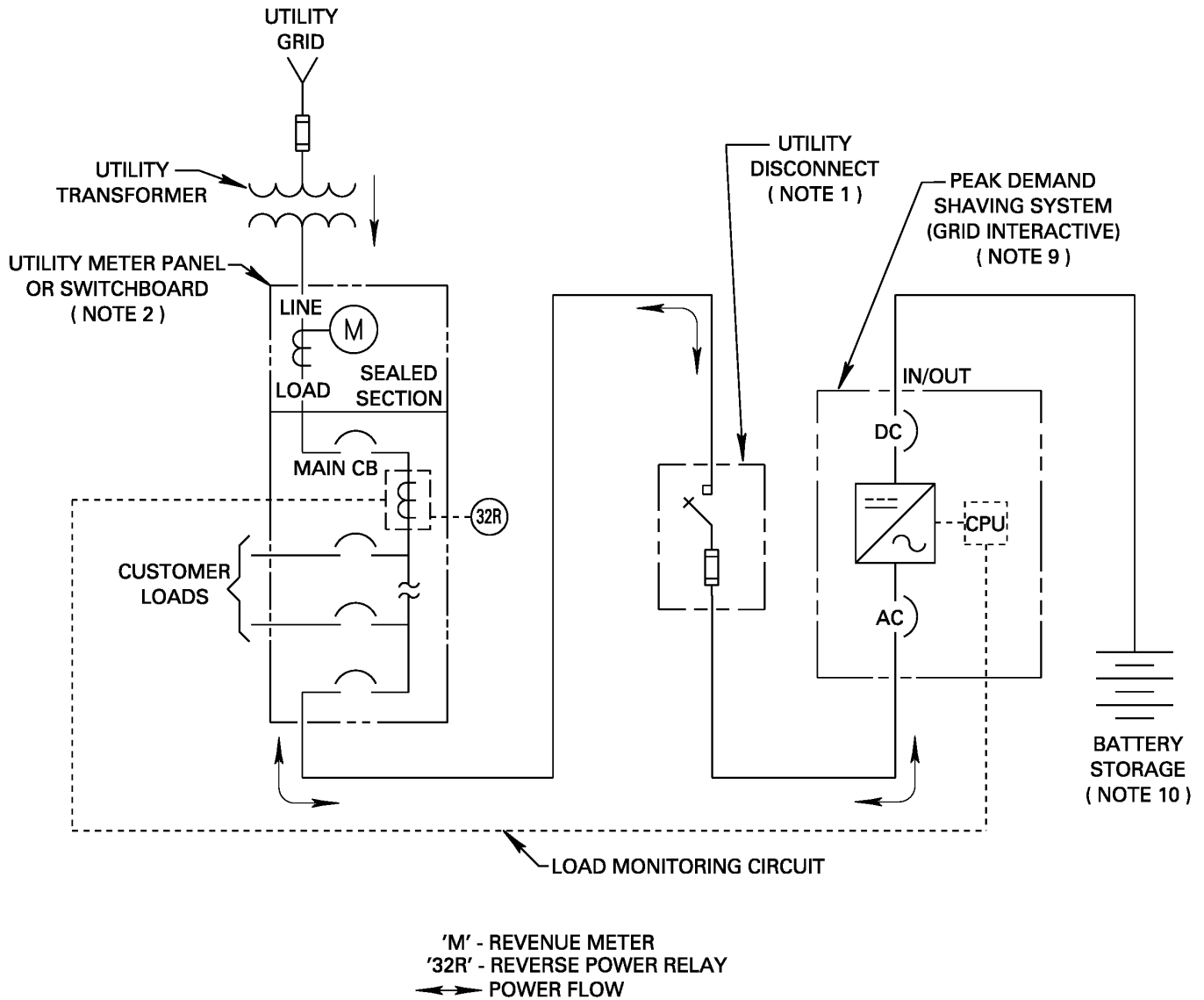
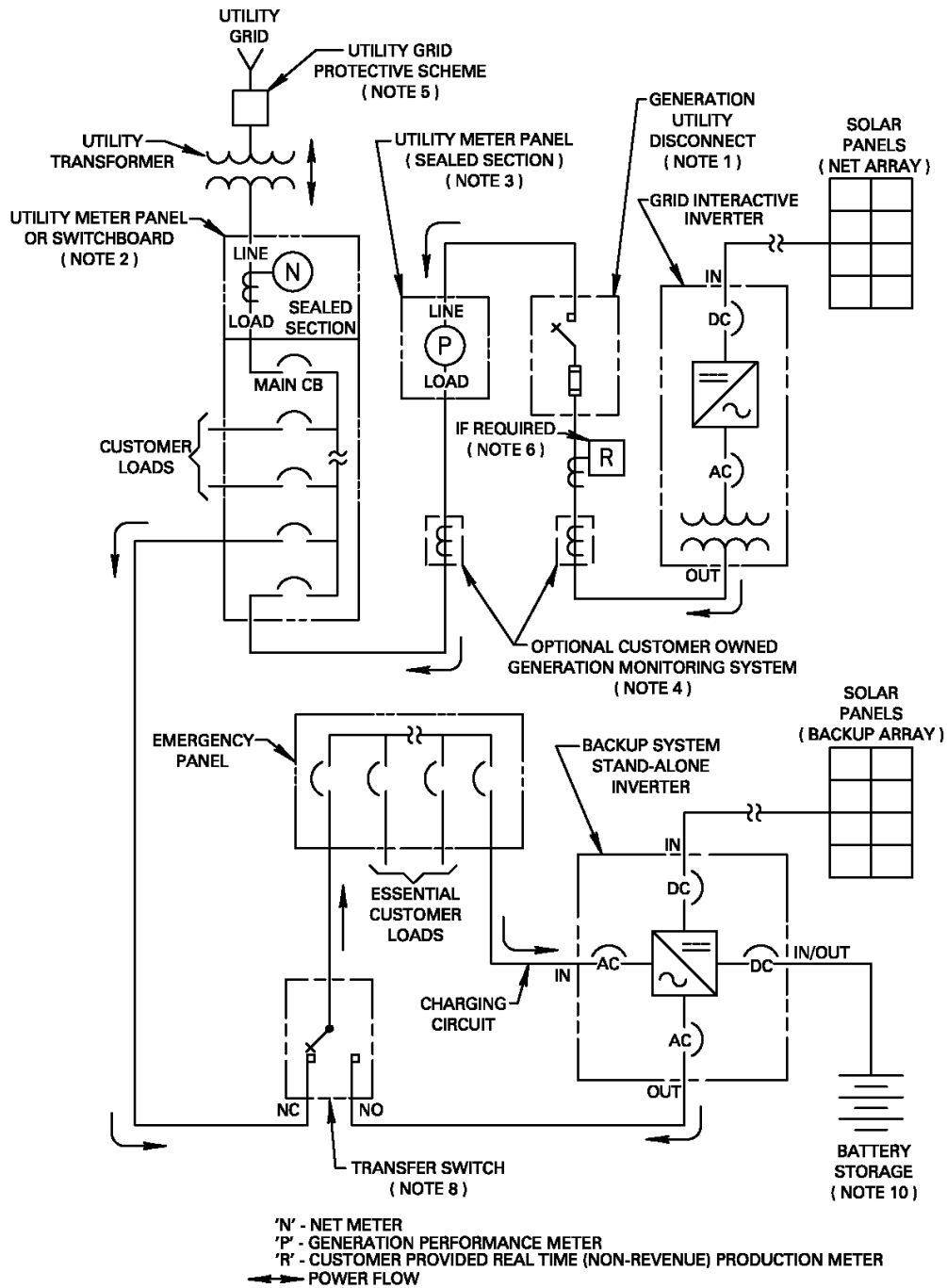

FIGURE 7

Note: This single line diagram has been simplified to illustrate the Department's interconnection requirements and does not necessarily represent all possible equipment arrangements. Contact the Los Angeles Department of Building and Safety (LADBS) or other Authority Having Jurisdiction (AHJ) for specific code requirements.

**TYPICAL INTERCONNECTION ARRANGEMENT
SOLAR NET ENERGY METERING + BATTERY BACKUP
AC-Coupled (GREATER THAN 30kW)**



*Solar NET energy metering is not available for total system capacities of 1MW and above.

FIGURE 8

Note: This single line diagram has been simplified to illustrate the Department's interconnection requirements and does not necessarily represent all possible equipment arrangements. Contact the Los Angeles Department of Building and Safety (LADBS) or other Authority Having Jurisdiction (AHJ) for specific code requirements.

TYPICAL INTERCONNECTION ARRANGEMENT
SOLAR NET ENERGY METERING WITH BATTERY ENERGY STORAGE SYSTEM (BESS) + BACKUP
DC-Coupled or AC-Back Coupled (30kW OR LESS)

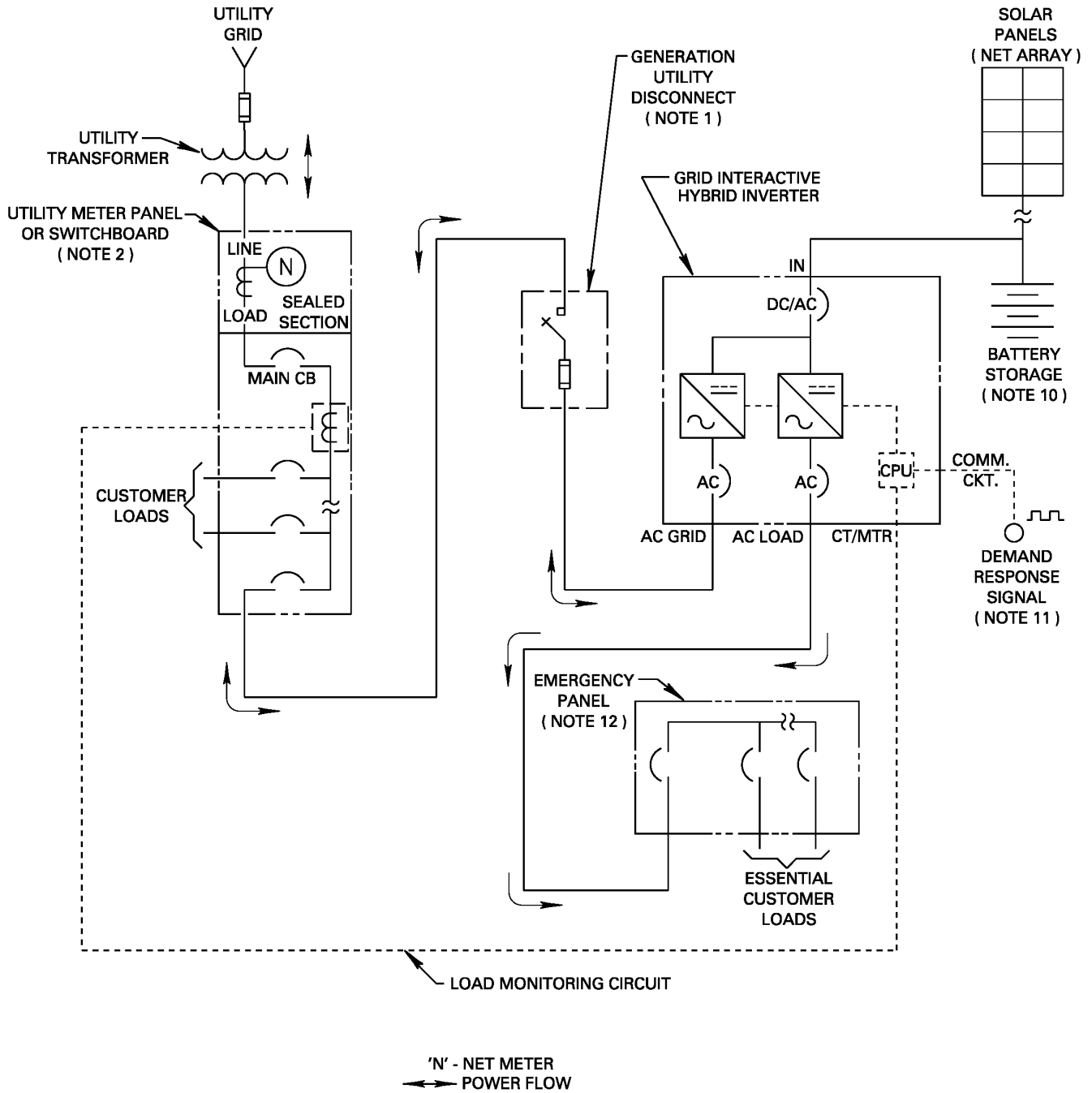
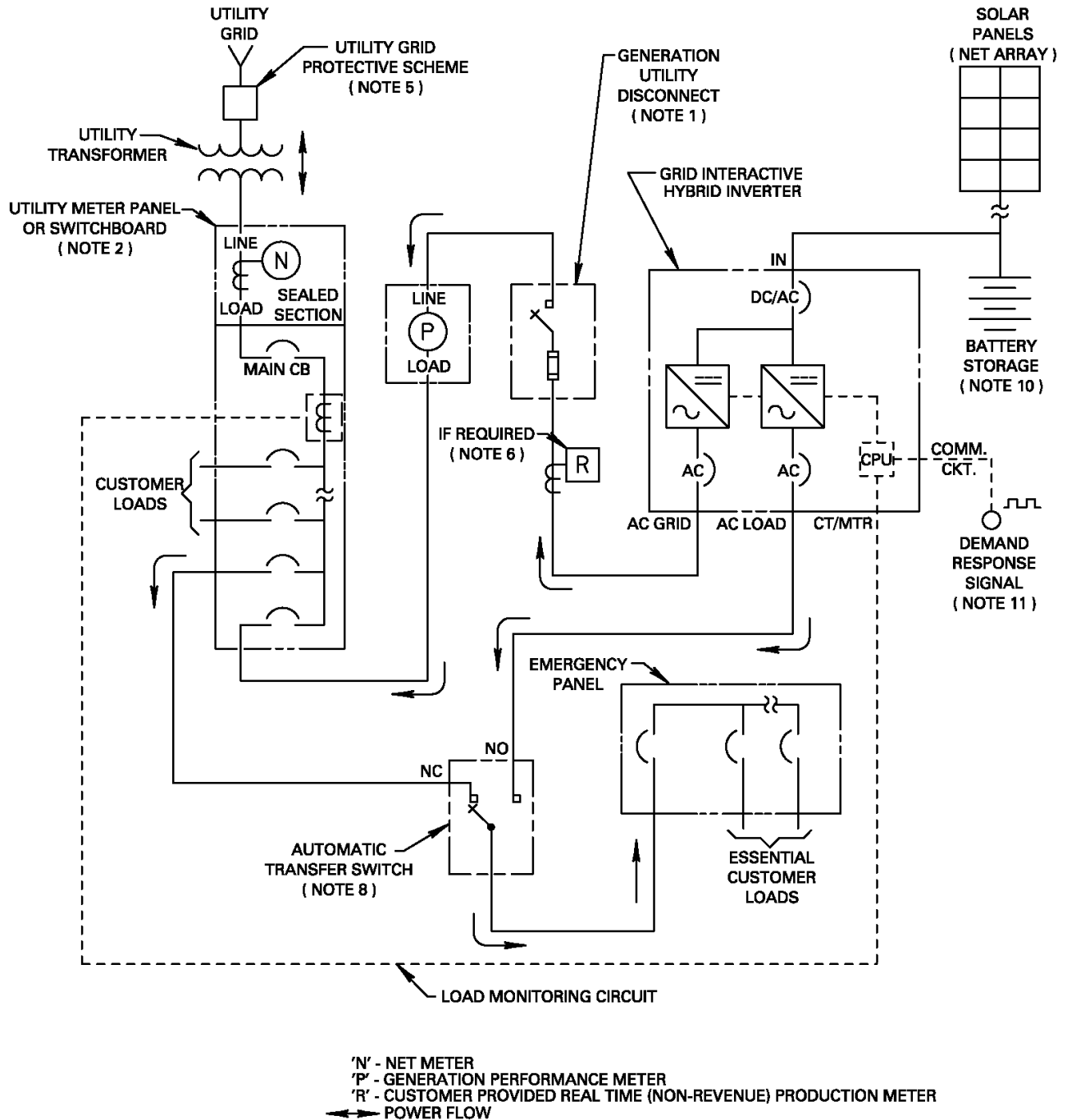

FIGURE 9

Note: This single line diagram has been simplified to illustrate the Department's interconnection requirements and does not necessarily represent all possible equipment arrangements. Contact the Los Angeles Department of Building and Safety (LADBS) or other Authority Having Jurisdiction (AHJ) for specific code requirements.

TYPICAL INTERCONNECTION ARRANGEMENT
SOLAR NET ENERGY METERING WITH BATTERY ENERGY STORAGE SYSTEM (BESS) + BACKUP
DC-Coupled or AC-Back Coupled (GREATER THAN 30kW)



*Solar NET energy metering is not available for total system capacities of 1MW and above.

FIGURE 10

Note: This single line diagram has been simplified to illustrate the Department's interconnection requirements and does not necessarily represent all possible equipment arrangements. Contact the Los Angeles Department of Building and Safety (LADBS) or other Authority Having Jurisdiction (AHJ) for specific code requirements.

TYPICAL INTERCONNECTION ARRANGEMENT
SOLAR NET ENERGY METERING WITH BATTERY ENERGY STORAGE SYSTEM (BESS) + BACKUP
AC-Coupled (30kW OR LESS)

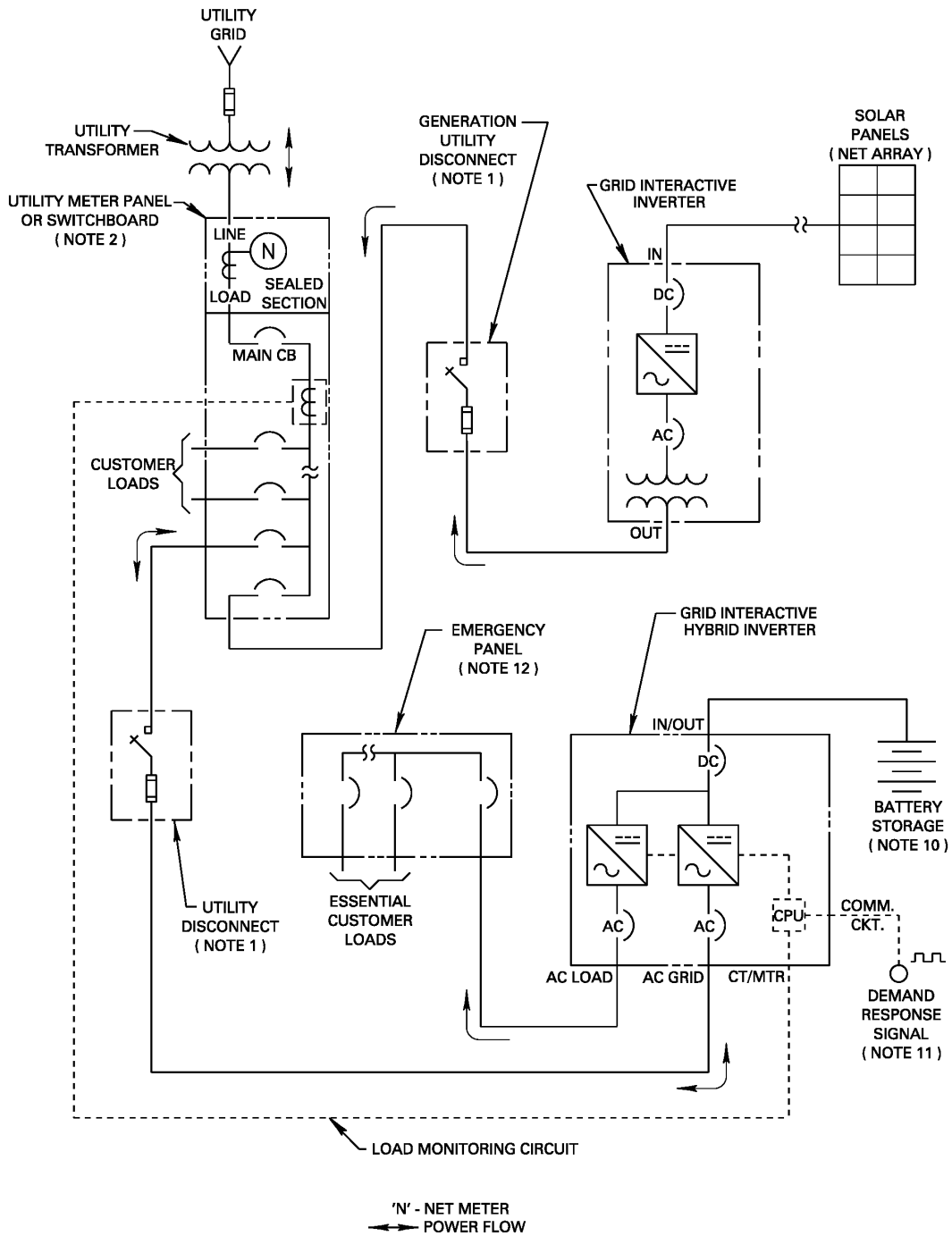
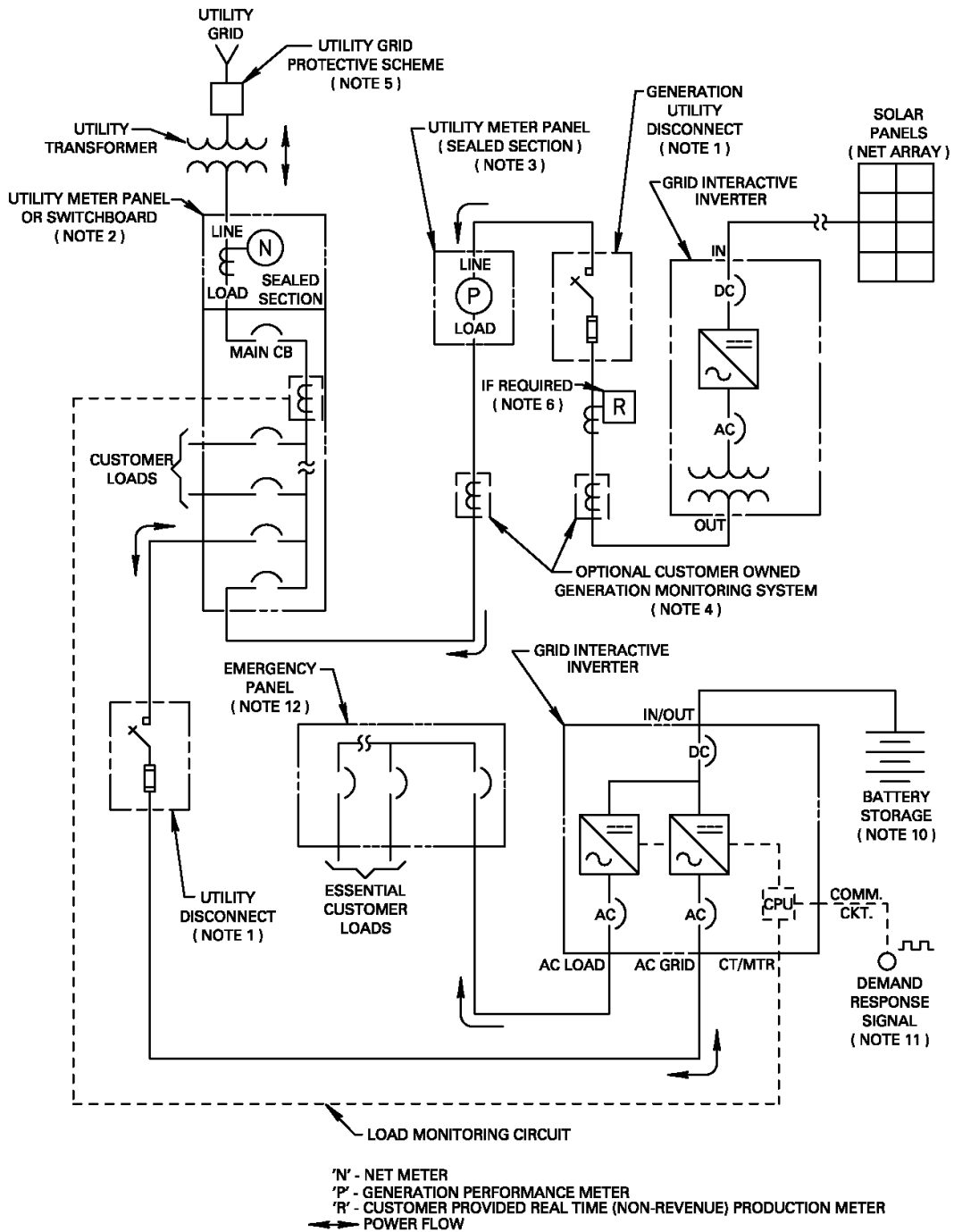

FIGURE 11

Note: This single line diagram has been simplified to illustrate the Department’s interconnection requirements and does not necessarily represent all possible equipment arrangements. Contact the Los Angeles Department of Building and Safety (LADBS) or other Authority Having Jurisdiction (AHJ) for specific code requirements.

TYPICAL INTERCONNECTION ARRANGEMENT
SOLAR NET ENERGY METERING WITH BATTERY ENERGY STORAGE SYSTEM (BESS) + BACKUP
AC-Coupled (GREATER THAN 30kW)



*Solar NET energy metering is not available for total system capacities of 1MW and above.

FIGURE 12

Note: This single line diagram has been simplified to illustrate the Department's interconnection requirements and does not necessarily represent all possible equipment arrangements. Contact the Los Angeles Department of Building and Safety (LADBS) or other Authority Having Jurisdiction (AHJ) for specific code requirements.

**TYPICAL INTERCONNECTION ARRANGEMENT
MICROGRID - SOLAR NET ENERGY METERING WITH BATTERY ENERGY STORAGE SYSTEM (BESS)
AC-Coupled with ISOLATION RELAY (30kW OR LESS)**

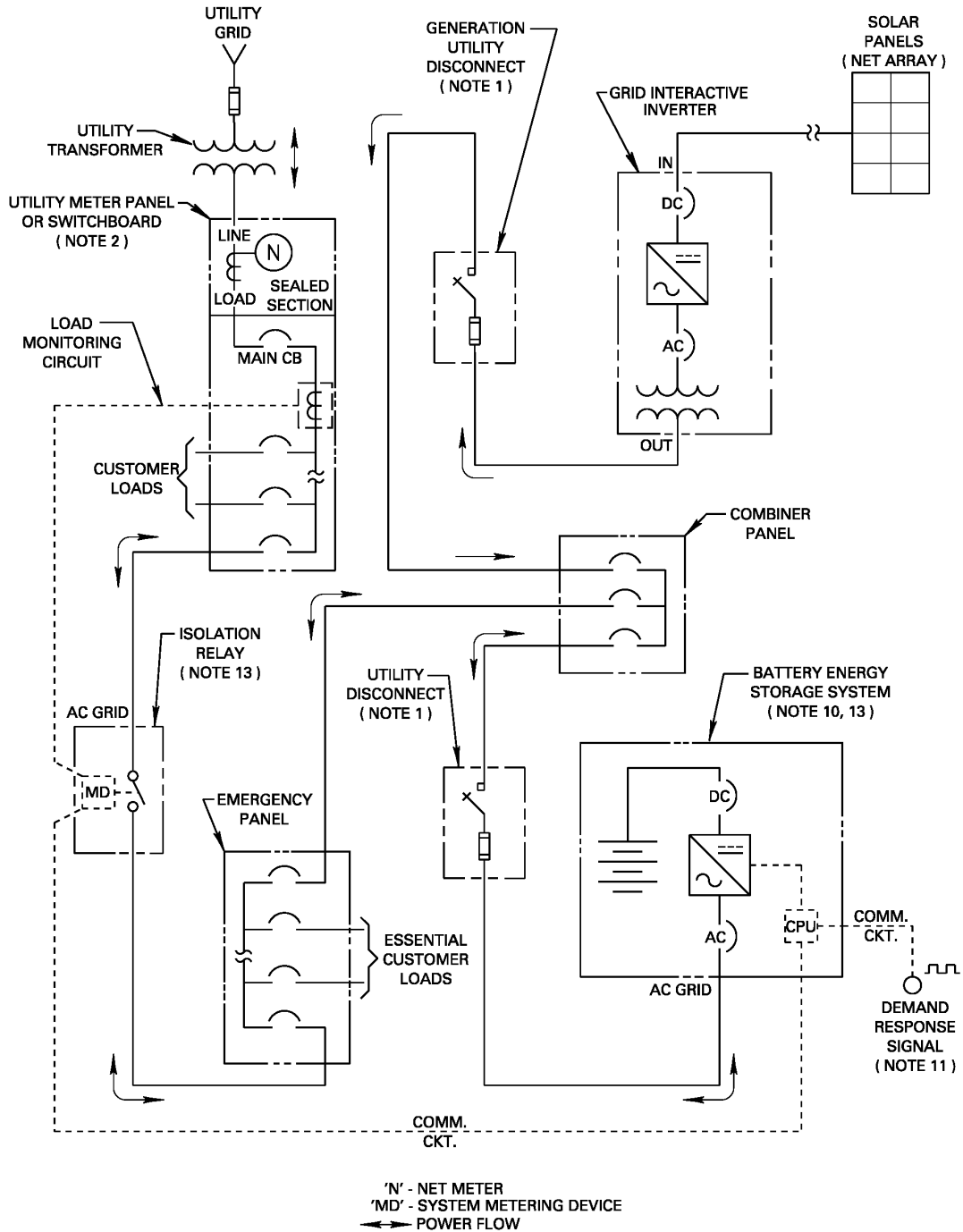
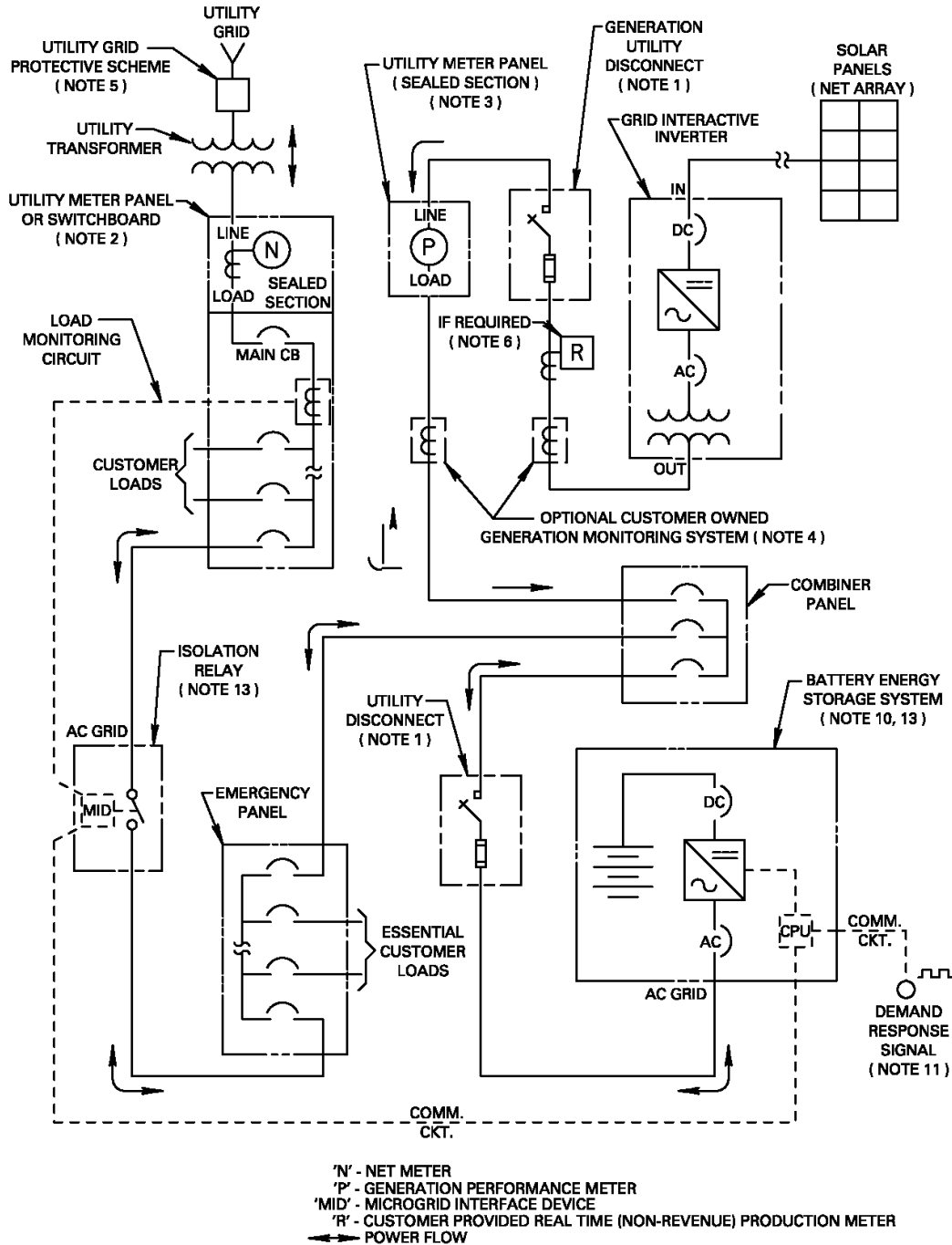

FIGURE 13

Note: This single line diagram has been simplified to illustrate the Department’s interconnection requirements and does not necessarily represent all possible equipment arrangements. Contact the Los Angeles Department of Building and Safety (LADBS) or other Authority Having Jurisdiction (AHJ) for specific code requirements.

TYPICAL INTERCONNECTION ARRANGEMENT
MICROGRID - SOLAR NET ENERGY METERING WITH BATTERY ENERGY STORAGE SYSTEM (BESS)
AC-Coupled with ISOLATION RELAY (GREATER THAN 30kW)



*Solar NET energy metering is not available for total system capacities of 1MW and above.

FIGURE 14

Note: This single line diagram has been simplified to illustrate the Department's interconnection requirements and does not necessarily represent all possible equipment arrangements. Contact the Los Angeles Department of Building and Safety (LADBS) or other Authority Having Jurisdiction (AHJ) for specific code requirements.

**TYPICAL INTERCONNECTION ARRANGEMENT
BATTERY ENERGY STORAGE SYSTEM (BESS) + BACKUP**

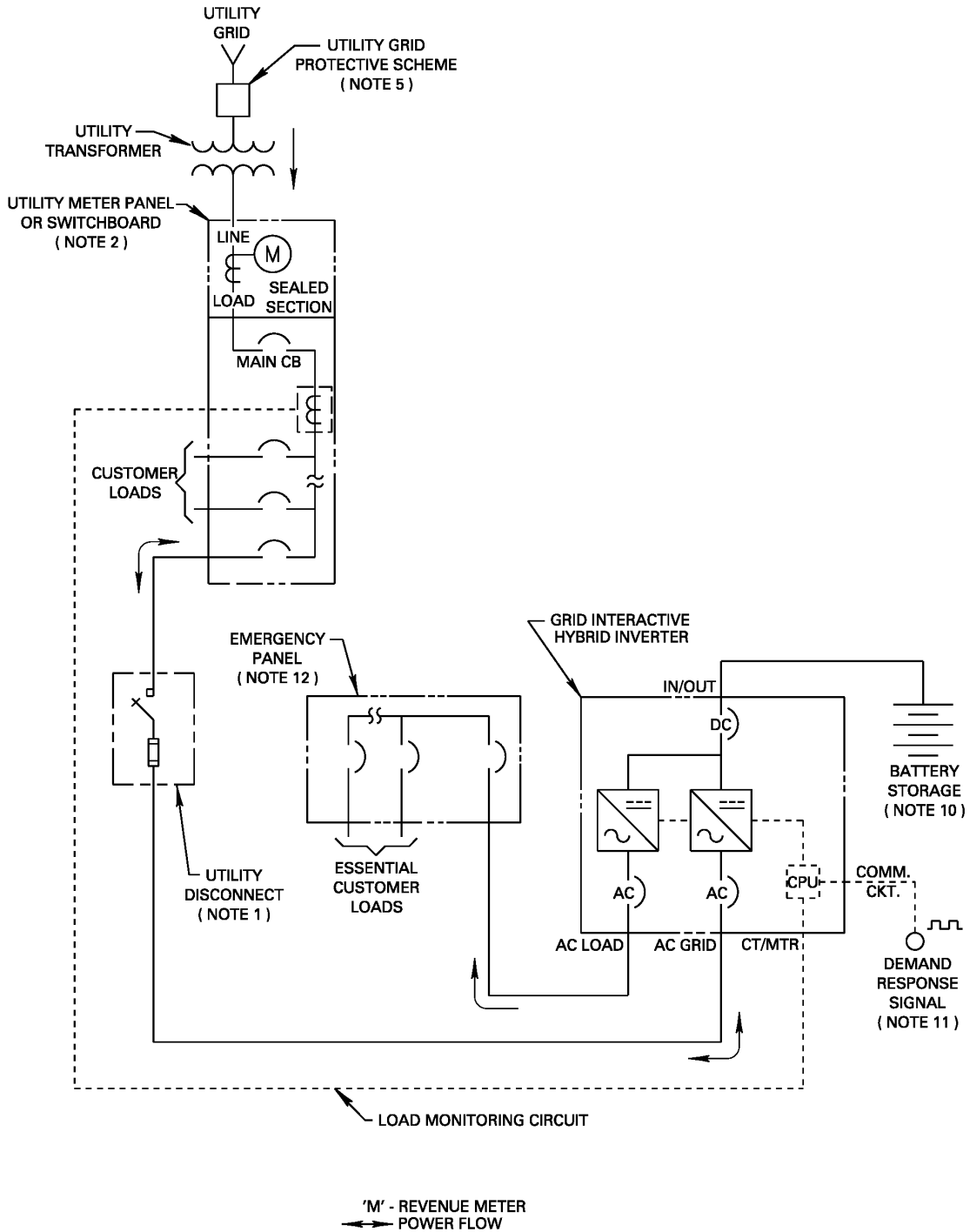

FIGURE 15

Note: This single line diagram has been simplified to illustrate the Department’s interconnection requirements and does not necessarily represent all possible equipment arrangements. Contact the Los Angeles Department of Building and Safety (LADBS) or other Authority Having Jurisdiction (AHJ) for specific code requirements.

**TYPICAL INTERCONNECTION ARRANGEMENT
MICROGRID - BATTERY ENERGY STORAGE SYSTEM (BESS)
with ISOLATION RELAY**

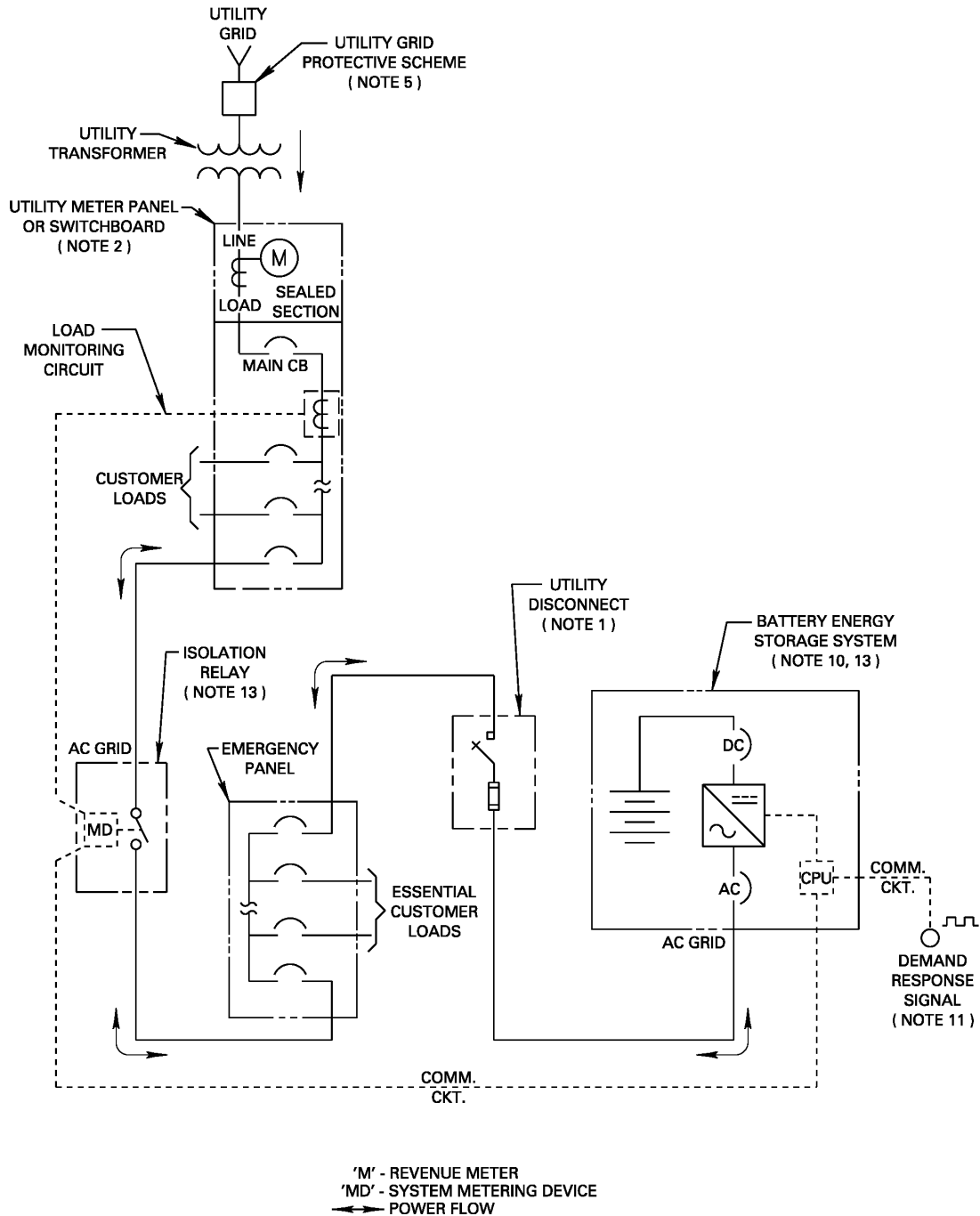

FIGURE 16

Note: This single line diagram has been simplified to illustrate the Department's interconnection requirements and does not necessarily represent all possible equipment arrangements. Contact the Los Angeles Department of Building and Safety (LADBS) or other Authority Having Jurisdiction (AHJ) for specific code requirements.

TYPICAL INTERCONNECTION ARRANGEMENT
SOLAR NET ENERGY METERING WITH BATTERY ENERGY STORAGE SYSTEM (BESS) + BACKUP
AC-Back Coupled with load panel (30kW OR LESS)

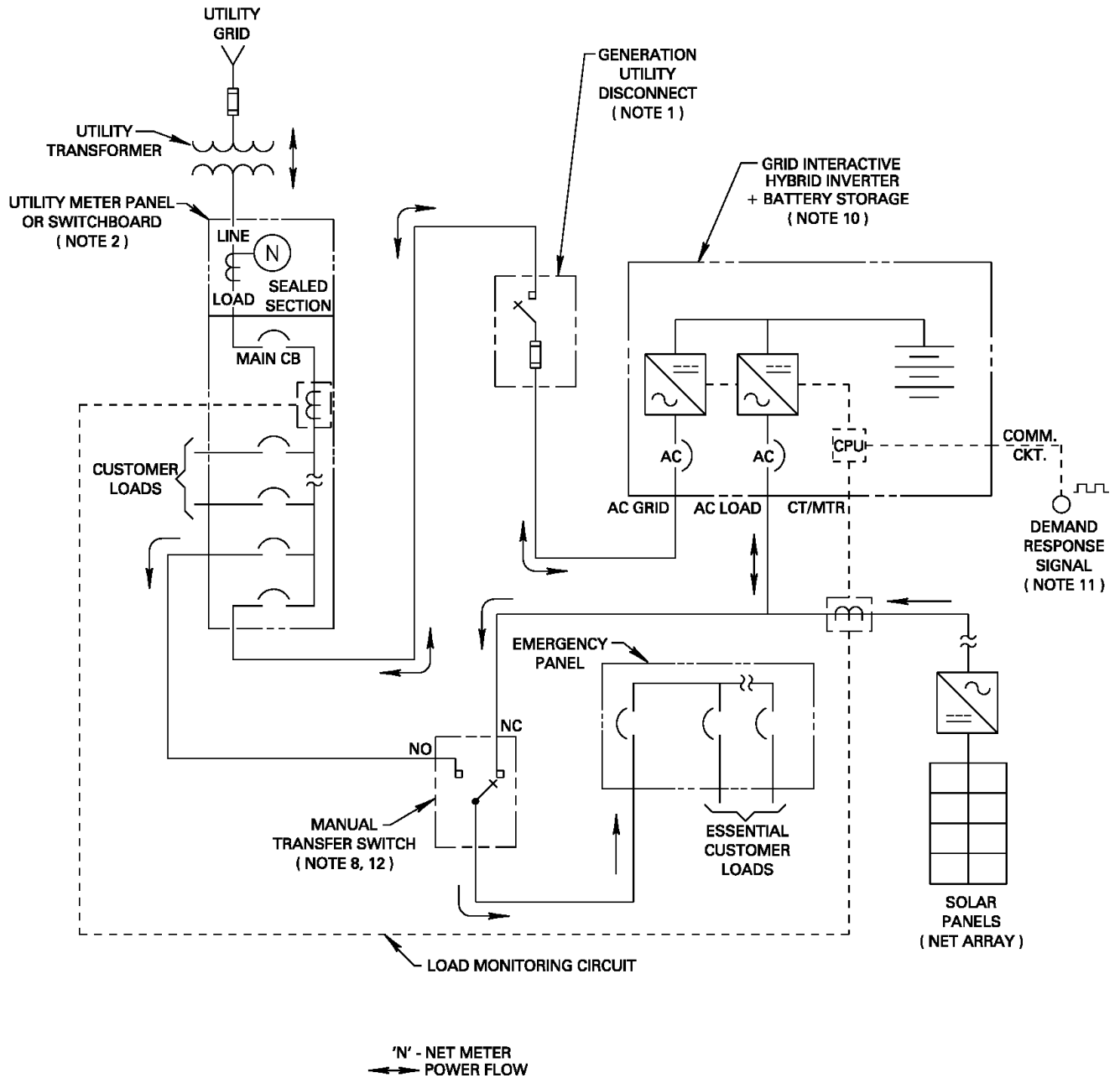
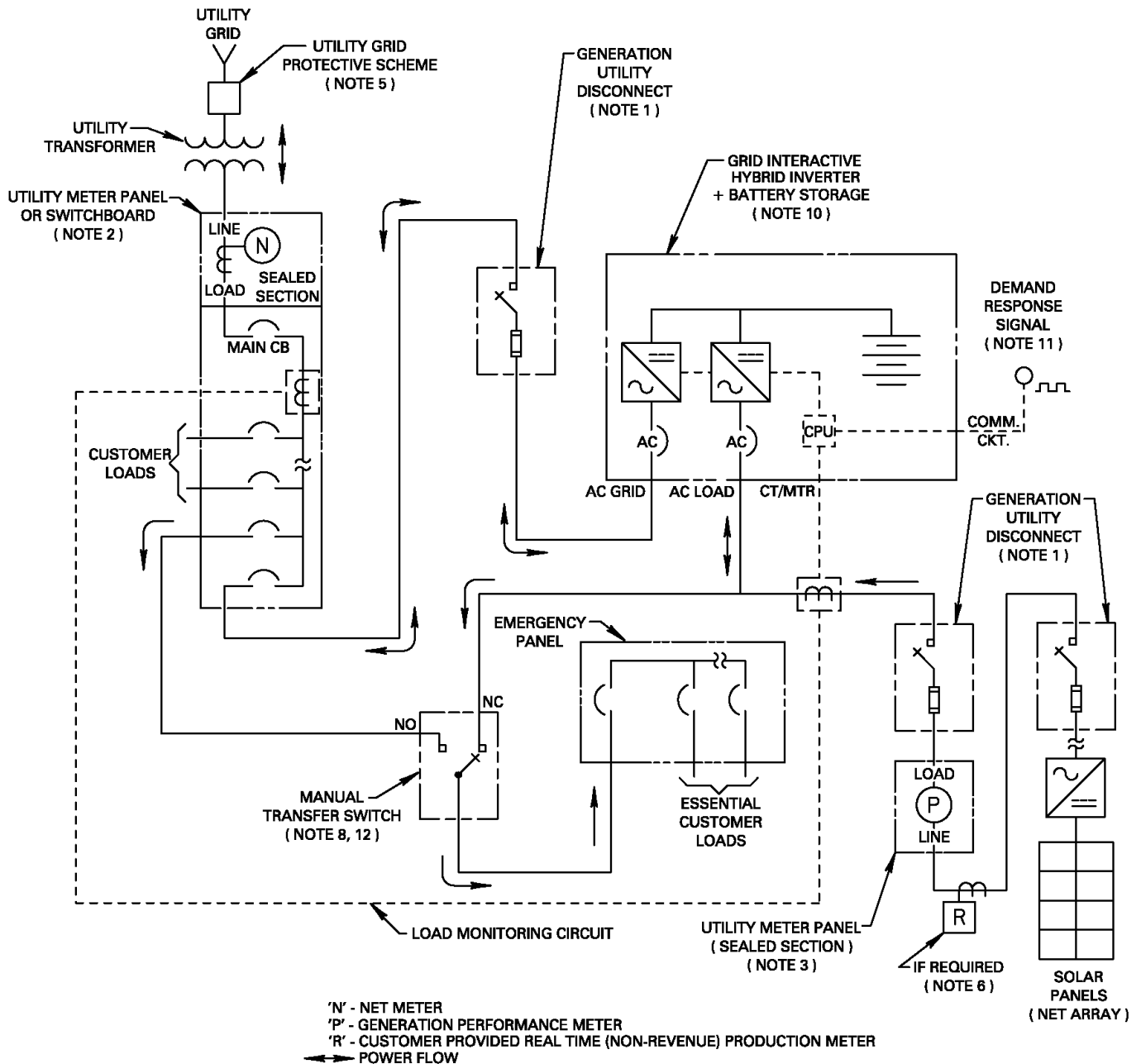

FIGURE 17

Note: This single line diagram has been simplified to illustrate the Department’s interconnection requirements and does not necessarily represent all possible equipment arrangements. Contact the Los Angeles Department of Building and Safety (LADBS) or other Authority Having Jurisdiction (AHJ) for specific code requirements.

TYPICAL INTERCONNECTION ARRANGEMENT
SOLAR NET ENERGY METERING WITH BATTERY ENERGY STORAGE SYSTEM (BESS) + BACKUP
AC-Back Coupled with load panel (GREATER THAN 30kW)



*Solar NET energy metering is not available for total system capacities of 1MW and above.

FIGURE 18

Note: This single line diagram has been simplified to illustrate the Department's interconnection requirements and does not necessarily represent all possible equipment arrangements. Contact the Los Angeles Department of Building and Safety (LADBS) or other Authority Having Jurisdiction (AHJ) for specific code requirements.

TYPICAL INTERCONNECTION ARRANGEMENT
SOLAR NET ENERGY METERING WITH BATTERY ENERGY STORAGE SYSTEM (BESS) + BACKUP
Alternate Design - AC-Back Coupled with load panel (30kW OR LESS)

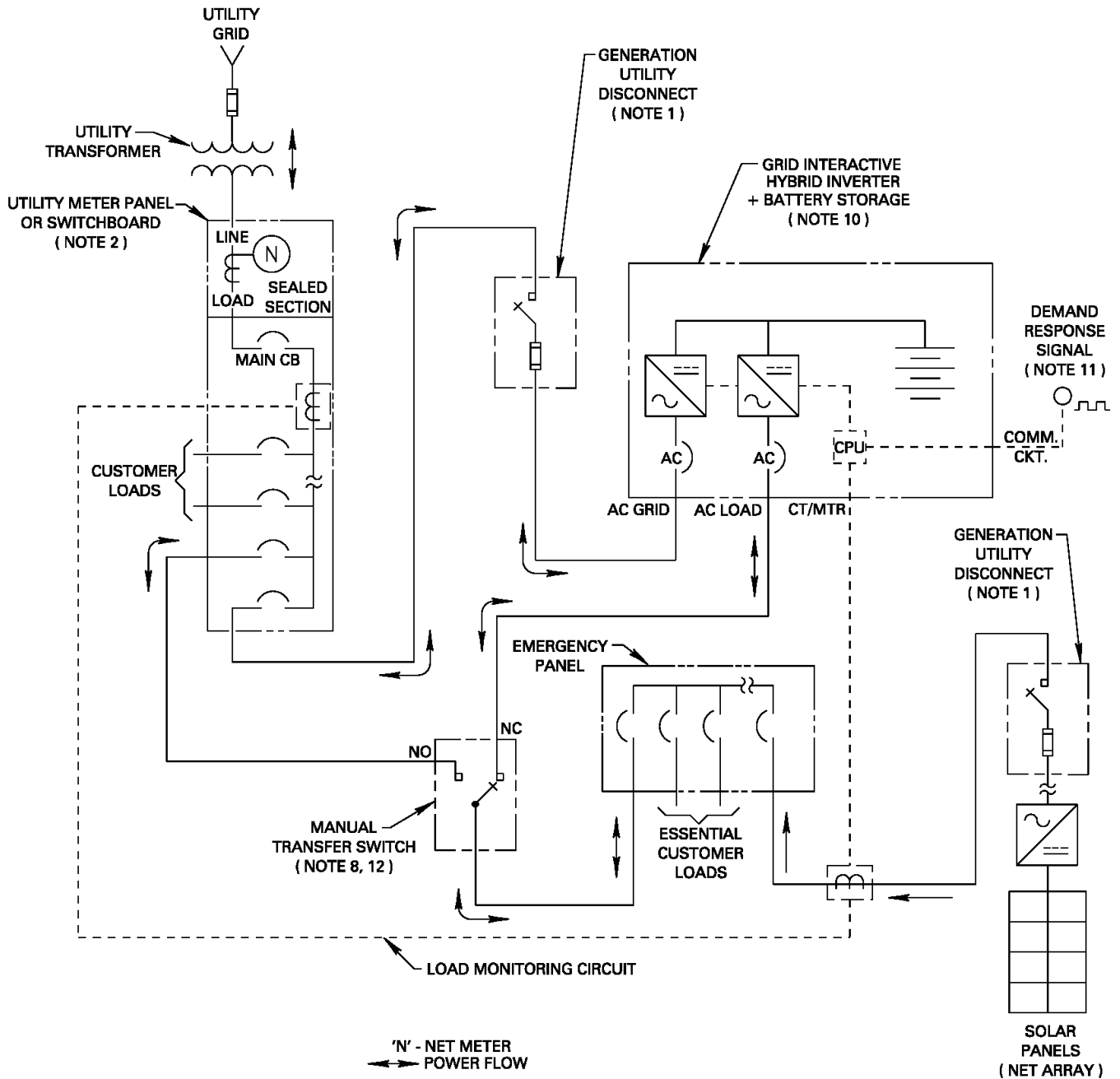
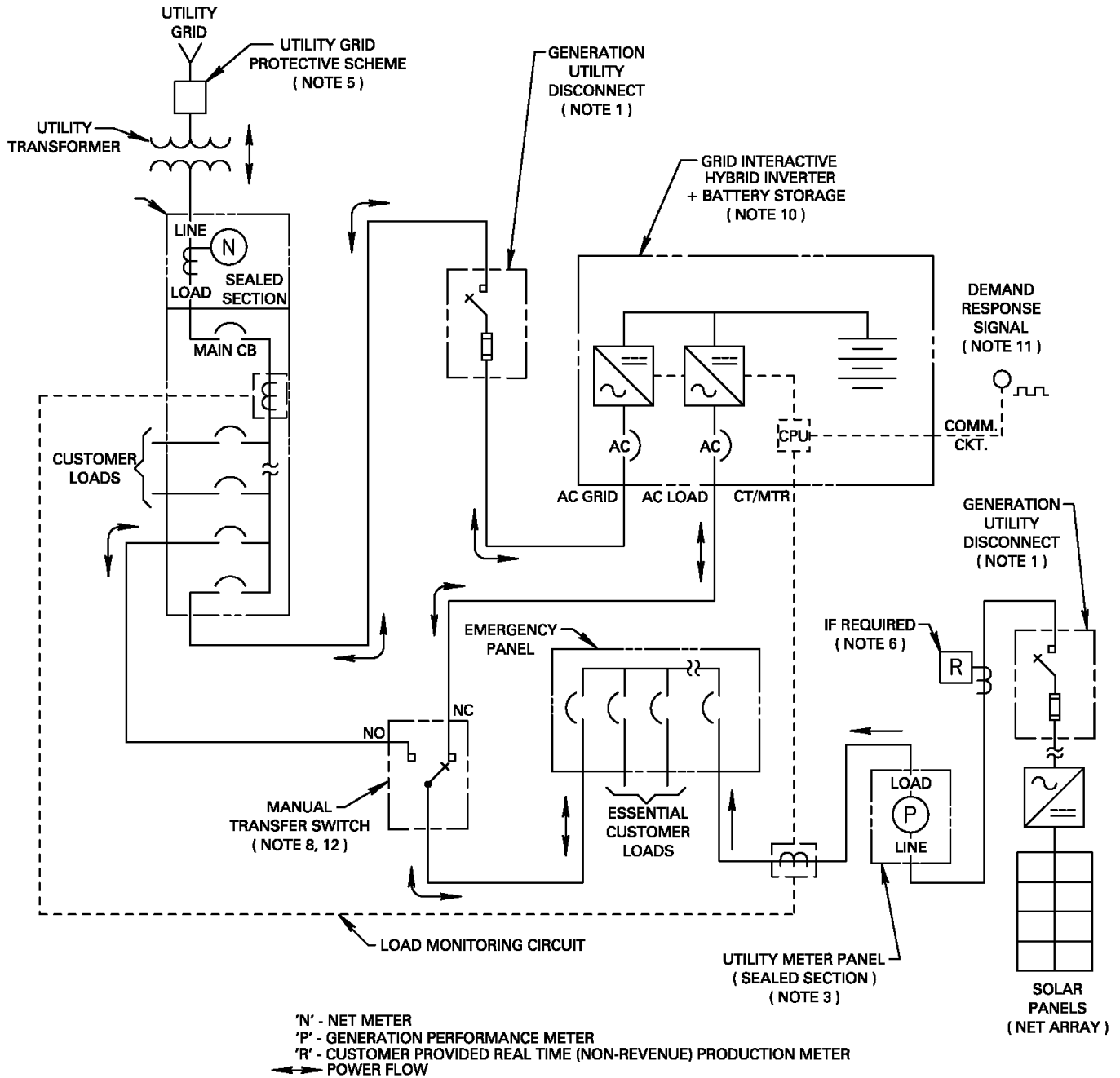

FIGURE 19

Note: This single line diagram has been simplified to illustrate the Department's interconnection requirements and does not necessarily represent all possible equipment arrangements. Contact the Los Angeles Department of Building and Safety (LADBS) or other Authority Having Jurisdiction (AHJ) for specific code requirements.

TYPICAL INTERCONNECTION ARRANGEMENT
SOLAR NET ENERGY METERING WITH BATTERY ENERGY STORAGE SYSTEM (BESS) + BACKUP
Alternate Design - AC-Back Coupled with load panel (GREATER THAN 30kW)



*Solar NET energy metering is not available for total system capacities of 1MW and above.

FIGURE 20

Note: This single line diagram has been simplified to illustrate the Department's interconnection requirements and does not necessarily represent all possible equipment arrangements. Contact the Los Angeles Department of Building and Safety (LADBS) or other Authority Having Jurisdiction (AHJ) for specific code requirements.

**TYPICAL INTERCONNECTION ARRANGEMENT
ENERGY STORAGE INTERCHANGE METERING (DER Locational Capacity Services Only)
(UTILITY-OWNED TRANSFORMER)**

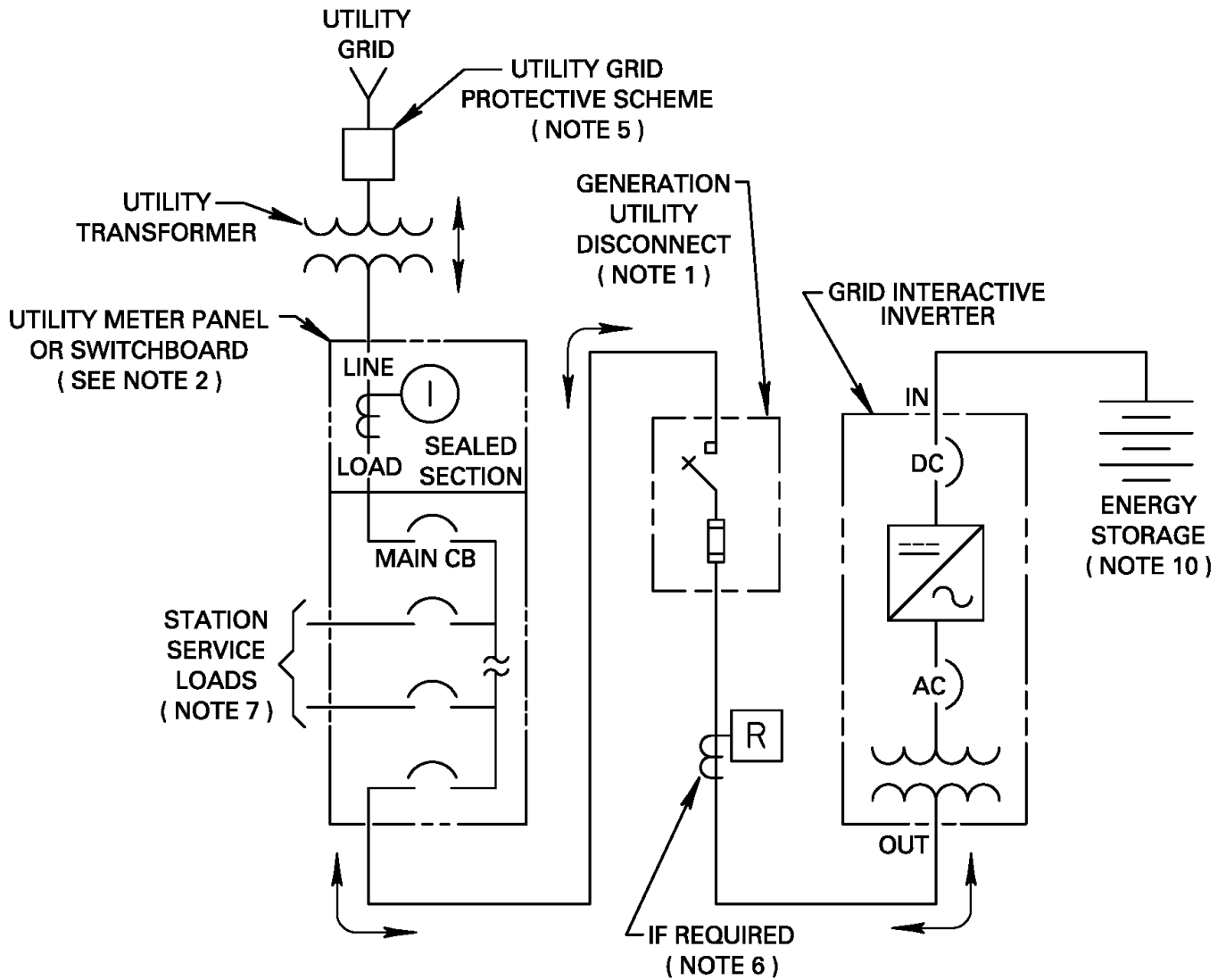

'I' - GENERATION INTERCHANGE METER
'R' - CUSTOMER PROVIDED REAL TIME (NON-REVENUE) PRODUCTION METER
↔ POWER FLOW

FIGURE 21

Note: This single line diagram has been simplified to illustrate the Department's interconnection requirements and does not necessarily represent all possible equipment arrangements. Contact the Los Angeles Department of Building and Safety (LADBS) or other Authority Having Jurisdiction (AHJ) for specific code requirements.

TYPICAL INTERCONNECTION ARRANGEMENT
ENERGY STORAGE INTERCHANGE METERING (DER Locational Capacity Services Only)
(CUSTOMER-OWNED TRANSFORMER)

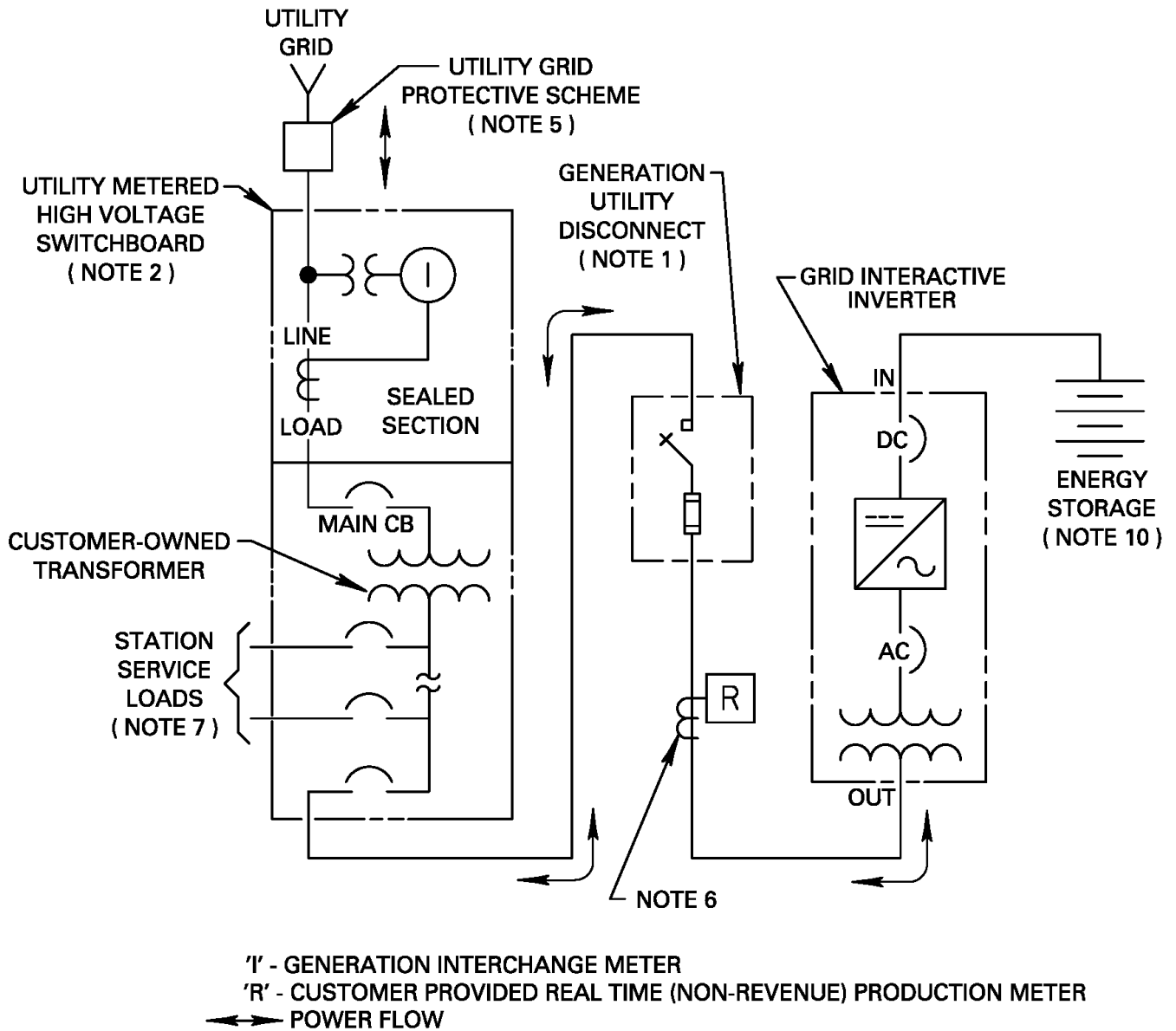

FIGURE 22

Note: This single line diagram has been simplified to illustrate the Department's interconnection requirements and does not necessarily represent all possible equipment arrangements. Contact the Los Angeles Department of Building and Safety (LADBS) or other Authority Having Jurisdiction (AHJ) for specific code requirements.

**TYPICAL INTERCONNECTION ARRANGEMENT
INVERTER BASED MICRO-TURBINE AND FUEL CELL GENERATION METERING**

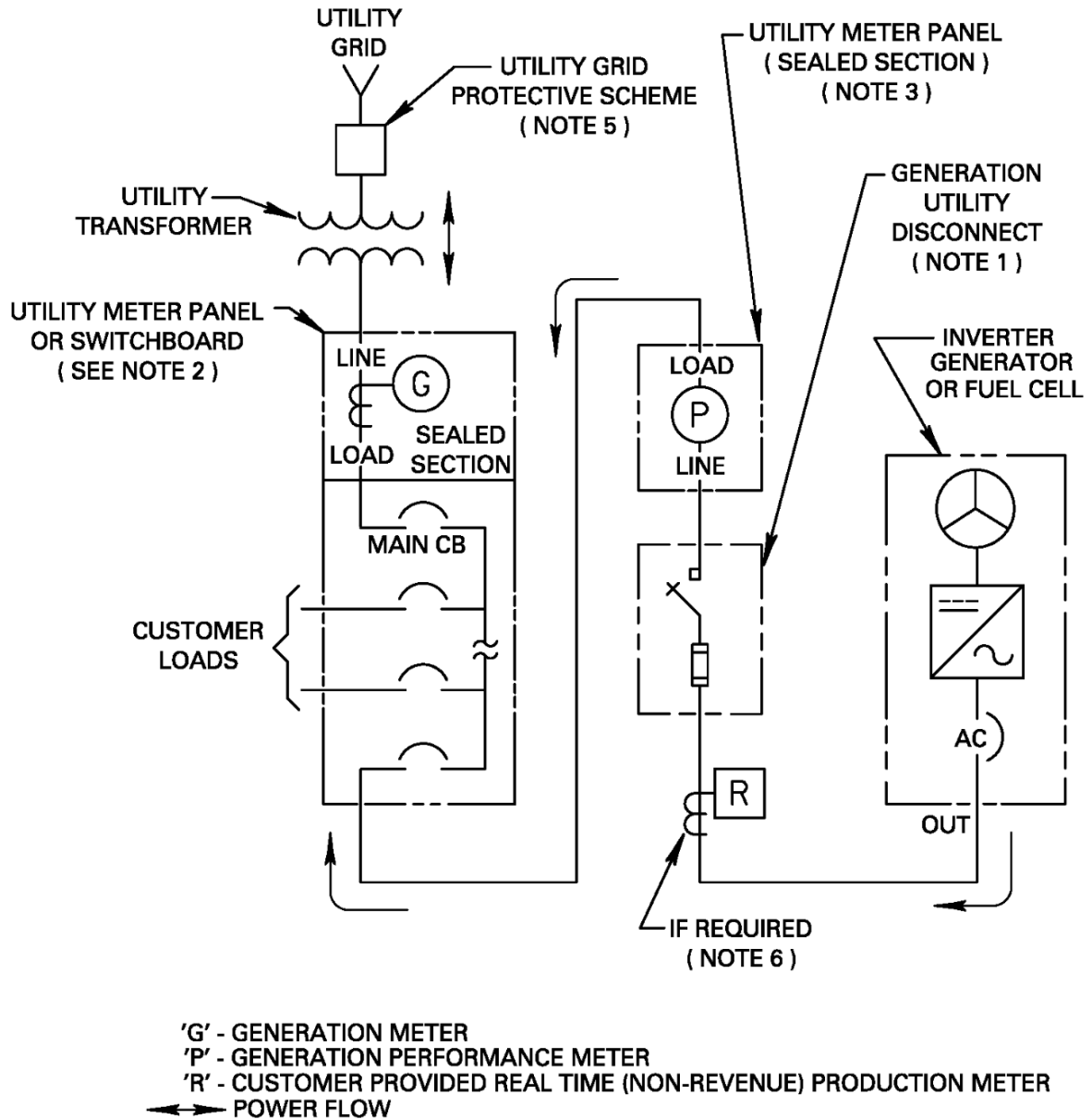
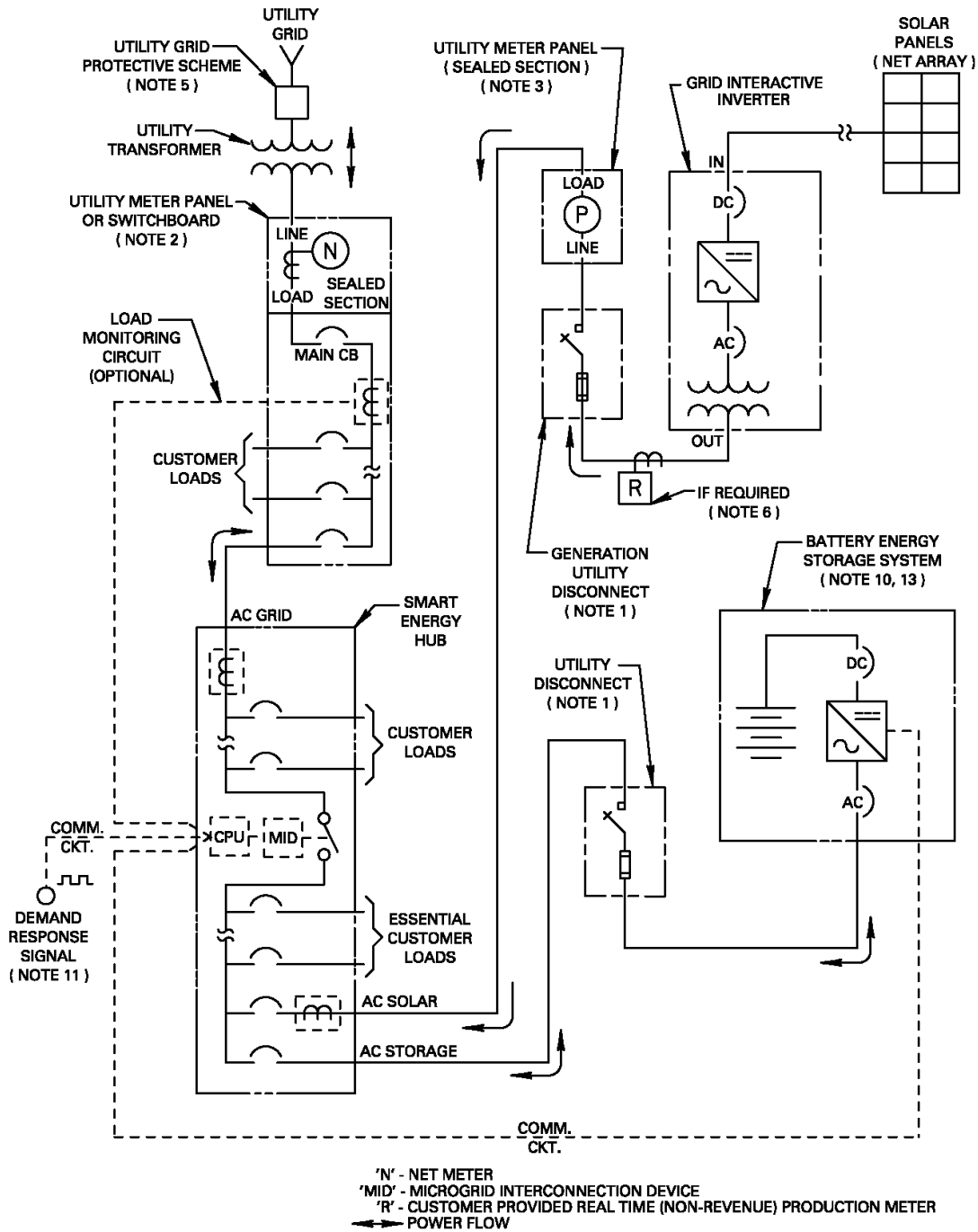

FIGURE 23

Note: This single line diagram has been simplified to illustrate the Department's interconnection requirements and does not necessarily represent all possible equipment arrangements. Contact the Los Angeles Department of Building and Safety (LADBS) or other Authority Having Jurisdiction (AHJ) for specific code requirements.

TYPICAL INTERCONNECTION ARRANGEMENT
MICROGRID - SOLAR NET ENERGY METERING WITH BATTERY ENERGY STORAGE SYSTEM (BESS)
Energy Hub with ISOLATION RELAY (GREATER THAN 30kW)



*Solar NET energy metering is not available for total system capacities of 1MW and above.

FIGURE 24

Note: This single line diagram has been simplified to illustrate the Department's interconnection requirements and does not necessarily represent all possible equipment arrangements. Contact the Los Angeles Department of Building and Safety (LADBS) or other Authority Having Jurisdiction (AHJ) for specific code requirements.

**THIS PAGE LEFT
INTENTIONALLY BLANK.**

Date: 05-02-24

DESIGN GUIDE FOR CUSTOMER-OWNED PARALLEL GENERATING SYSTEMS

NOTES:

1. The customer shall furnish, install, and maintain all generation disconnect switches as required by the Department.
 - a. An AC disconnect switch shall be located on the customer's energy source side of the generation performance meter. Consult with the Department for mounting heights and clearances.
 - b. A single fusible disconnect may be used in place of a separate circuit fuse and AC disconnect. The fusible disconnect shall meet the same visual air gap and locking requirements as the AC disconnect and shall not be used to isolate the customer's load panel. See **UTILITY DISCONNECTING MEANS**, page 8-6 for additional information.
2. The customer's generating system circuit shall be connected on the load side of the customer's main service disconnecting means as shown in figures 1 to 5, and 7 to 24.

Exception: Parallel generating systems may be connected on the line side of the customer's disconnecting means as permitted by City, State or National Electric Codes. See **GENERATORS AND GENERATING SYSTEMS**, page 8-10 for additional information.
3. The customer shall provide a meter socket for the installation of a Department performance meter. A residential meter panel or a commercial safety-socket meter panel is required when the maximum output of the generating system does not exceed 200 amperes. When the system output exceeds 200 amperes, a current-transformer box or instrument-rated switchboard is required.

Note: The performance meter is intended to measure the total output of the customer's generating system. With the exception of monitoring equipment, no customer load is permitted on the generating system side of the performance meter. Under certain circumstances, and if required to measure total generation output, the Department may install additional performance meters at the customer's expense. See **METERING**, page 8-4 for additional information.
4. Optional customer installed performance monitoring equipment may be installed with restrictions, see **METERING** page 8-4. Customers who wish to monitor their generations performance should consider consulting with their contractor for options when a Department supplied performance meter is not available.
5. The type of utility grid protection scheme required is dependent upon the size, type, and configuration of the customer's generation system, see **PROTECTIVE SCHEMES** page 8-7.
6. Customer provided real time production monitoring equipment may be required as specified by the Department, see **PROTECTIVE SCHEMES** page 8-7.
7. Currently, customer loads shall not be supplied from a feed in tariff (FIT) system. The customer must apply for a separate revenue meter and service from the Department.
8. An automatic transfer switch (ATS), manual transfer switch, or double throw safety switch shall be installed between the customer's backup system and the Department's revenue meter, see **BATTERY BACKUP SYSTEMS** page 8-12 and **EMERGENCY OR STAND-BY GENERATORS** page 1-32.
9. All systems that are designed to manage a customer's peak energy demand shall be grid interactive, see **INVERTERS** page 8-11. Shall not be used with Department Generation or NET energy metering, and shall not allow for the export of energy to the Department's grid. All related devices shall be connected on the load side of the customer's main circuit breaker, see **BATTERY PEAK SHAVING SYSTEMS** page 8-13.
10. **Batteries shall not be located in the meter room.** See pages 5-9 and 5-10 for more information. Contact the Los Angeles Department of Building and Safety (LADBS) or other Authority Having Jurisdiction (AHJ) for specific code requirements.

NOTES (Cont.):

11. Used for battery dispatch. No requirement at this time, standards are under development.
12. A normally open, maintenance bypass mechanical interlock shall be installed on an emergency panel provided it is affixed to the panel in a permanent, tamper-resistant fashion and is listed by a Nationally Recognized Testing Laboratory (NRTL) as an interlock device.
Note: A double throw safety switch or ATS may also be used.
13. Battery energy storage system equipment that includes external isolation relays as part of an integral system shall be certified by a Nationally Recognized Testing Laboratory (NRTL) to comply with the UL 9540 standard.

**THIS PAGE LEFT
INTENTIONALLY BLANK**

CONTENTS

	<u>PAGE</u>
Index	9-1
EUSERC/ESR Cross Reference and Acceptability Index	9-9
Glossary	9-11
Summary of Revisions	9-16

Date: 05-02-24

INDEX AND GLOSSARY

INDEX

Section 1, General Information	1-1
Section 2, Service and Metering Equipment	2-1
Section 3, Low-Voltage Switchboards, 0-600 Volts	3-1
Section 4, Medium-Voltage Switchgear, 2400-4800 Volts	4-1
Section 5, Design and Installation Guide for Service and Metering Equipment	5-1
Section 6, Design and Installation Guide for Conduit Systems on Private Property	6-1
Section 7, Design and Installation Guide for Overhead Services, 0-600 Volts	7-1
Section 8, Design Guide for Customer-Owned Parallel Generating Systems	8-1
Section 9, Index, Glossary, and Summary of Revisions	9-1

A

Accessory Dwelling Units (ADU)	5-33
Angle Iron Racks, Overhead Service	7-16, 7-17
Application for Service	1-7, 1-29
Applications, Use of Service and Metering Equipment	2-10, 3-11
ARC Flash Determination and Short-Circuit Study policy	1-28
Attachment brackets for Service Drop Conductors (See Overhead Services, Design and Installation Guide)	

B

Barrier Posts	5-15, 5-17, 5-18
Barriers, Service and Metering Equipment	3-4, 4-2
Bonding	2-9, 3-10, 4-3
Busway Services	1-36, 3-48, 7-15

C

Certification of Meter and Service Equipment	1-39, 4-3
Changes in Connected Load	1-21
Character of Service	1-25
Classes of Service	1-27
Clearances:	
Service and Metering Equipment	5-8, 5-12, 5-13, 5-14, 5-15, 5-16, 5-18, 5-20, 5-21
Service Drop Conductors	7-4
Conduits:	
Bends	6-4
Concrete Encasement	6-5
Depth	6-4
Types of (metallic and nonmetallic)	6-3, 6-4
Pull Tape	6-6
Risers, Conduit	6-6, 7-14, 7-16, 7-18, 7-20
Sizes	6-3
Spacing Between Ducts	6-5
Conduit Entering a Building Structure	6-7
Cooking Loads	1-22
Current Transformers:	
601-4800 Volts	4-14
34500 Volts	4-32
Current-Transformer Compartments	3-20, 3-22, 3-24, 3-26, 3-28, 4-5, 4-26, 4-27
Current-Transformer Boxes, Wall-Mounted	2-34, 2-36

INDEX AND GLOSSARYDate: 12-01-23

INDEX (Cont.)**C (Cont.)**

Current-Transformer Mounting Bases, 600 Volts Maximum	2-38, 2-39, 2-40, 2-41, 3-30, 3-31
Current-Transformer Mounting Base, 601-4800 Volts	4-16
Current-Transformer Mounting Rails, 34500 Volts	4-31
Customer-Owned Generators	1-32, 1-38, 8-1
Customer Service Branch Offices	1-4
Customer Service Planning Offices	1-3

D

Dig Alert	1-6
Design and Plan Approval	1-7

E

Electric Trouble	1-7
Electric Loads:	
Affecting other Customers	1-21
Changes in Load	1-21
Insufficient Load	1-21, 1-37
Lighting	1-22
Single-Phase Motors	1-21
Special Equipment	1-23
Three-Phase Motors	1-21
Welders	1-22
X-Ray Equipment	1-22
Electric Vehicle Installations	1-18, 5-30, 5-31, 5-32
Engineering Offices (Service Planning)	1-4
EUSSRC/ESR Cross Reference and Acceptability Index	9-9

F

Fees and Charges	1-8, 1-24, 1-29, 1-36, 8-3
Fiber-Optic Installations	5-24
Fire Pump Service	1-38
Flat Connected Services	1-31

G

Gas Appliances	5-14
Gas Dispensing and Station Service Installations	5-26
Gas Meter, Natural	5-11
Generators (Emergency or Stand-By) and Generating Systems (Parallel-Generation)	1-32, 1-37, 8-2
Glossary	9-11
Grounding	2-9, 3-10, 4-3

H

Hazardous Areas Installations	5-26
Heating Loads	1-22
Housekeeping Pads	5-14, 5-17, 5-18

Date: 05-02-24

INDEX AND GLOSSARY

INDEX (Cont.)

I

Inspections	1-24
Instrument-Transformer Compartments-Low Voltage	3-20, 3-22, 3-24, 3-26, 3-28
Instrument-Transformer Compartments-High Voltage	4-5
Insufficient Loads	1-21, 1-37
Inverters	8-10

L

Labeling Requirements, Service and Metering Equipment	2-10, 3-11, 4-3
Lifting Handles	2-9, 3-10, 4-2
Lighting Loads	1-22

M

Main Service Switch-Group Metering	2-7, 3-8
Mandrelling Conduits	6-6
Methane Gas Hazard Areas	5-24
Meter Enclosure, Medium Voltage	4-3
Meter Heights and Clearances	5-12, 5-16, 5-18, 5-20, 5-21, 5-22
Meter locations:	
Commercial and Industrial	5-4
Residential	5-4
Added Metering Equipment	5-4
Unacceptable Locations	5-5
Meters, Identifying in Multi-meter installations	5-6
Meter Cabinets	5-20
Meter Connections and Wiring	2-6
Meter Rooms:	
Access	5-7
Doors	5-7
Equipment Arrangements	5-8
Foreign Equipment	5-9
Identification	5-8
Locations	5-7
Locking Provisions	5-5
Communication	5-10
Illumination	5-10
Meter Panels:	
Commercial	2-26, 2-28, 2-34, 2-36, 2-38, 2-44, 3-12, 3-14, 3-34
Group Metering	2-24, 3-34, 3-36
Industrial	2-26, 2-28, 2-34, 2-36, 2-38, 3-12, 3-14, 3-34, 4-5
Instrument-Rated	2-36, 2-38, 3-12, 3-14, 4-10, 4-27
Residential	2-18, 2-22, 2-48, 3-36
Self-Contained	2-20, 2-22, 2-24, 2-26, 2-28, 2-44, 2-48, 3-34, 3-36
Meter Socket Jaw Arrangements	2-5
Meter Sockets	2-3, 3-4, 4-3
Meter Sequence	2-7, 3-6
Meter Switch	2-6, 3-7, 4-3

INDEX AND GLOSSARYDate: 05-02-24

INDEX (Cont.)**M (Cont.)**

Meter Wiring Raceway	3-6
Mobile Home (Trailer) Post.	2-48
Motors, Single-Phase and Three-Phase	1-21

O

Overhead Services, Design and Installation Guide	7-1
Service Drops:	
Allowable Length	7-2
Attachments	7-9, 7-17, 7-18, 7-20, 7-22, 7-24, 7-26
Clearances:	
Buildings, Vertical Clearances above	7-4
Doors, Exits, Windows, Fire Escapes, Stairs	7-5
Other Conductors	7-9
Railroad Tracks	7-6
Signs	7-9
Swimming Pools	7-8
Walkways, Driveways and Thoroughfares-Public and Private Property	7-6
Number Supplied	7-2
Service Heads:	
Busway Requirements	7-15, 3-3, 3-48
Locations	7-15
Replacement or additional	7-16
Riser Conduits	7-14
Service Entrance Conductors	7-14
Service Pole, Metal Pole, Permanent/Temporary	7-26
Service Pole, Wood, Permanent/Temporary	7-24
Service Pole, Temporary (1 Year Maximum Service)	7-22
Service Pole, Pedestal, Permanent/Temporary	7-28

P

Parallel generating Systems:	1-17, 1-32, 8-1
Battery Energy Storage (BESS)	8-13, 8-14
Data Required for Design	8-2, 8-3
Disconnection of Customer's Energy Source:	
General	8-5
Notification	8-5, 8-6
Electric Rates	8-3
Generators	8-10, 8-11
Generator Disconnects:	
General	8-6
Access	8-6

Date: 05-02-24

INDEX AND GLOSSARY

INDEX (Cont.)

P (Cont.)

Parallel generating Systems (Cont.)	1-17, 1-32, 8-1
Informational Signs	8-7
Inspections	8-5
Interconnection Agreements	1-16, 1-17, 8-2, 8-3
Interconnection Costs	8-3
Interconnection Arrangement Schematics, Typical:	
Solar Net Energy Metering (less than 10kW)	8-15
Solar Net Energy Metering (10kW or greater)	8-16
Solar Feed In Tariff (FIT) with Department Owned Transformer	8-17
Solar Feed In Tariff (FIT) with Customer Owned Transformer	8-18
Synchronous Generation Metering	8-19
Battery Backup	8-20
Battery Only Peak Demand Shaving	8-21
Solar Net Energy Metering with Battery Backup	8-22
Battery Energy Storage (BESS)	8-23, 8-24, 8-25, 8-26, 8-27, 8-28, 8-29, 8-30, 8-31, 8-32, 8-33, 8-34, 8-35, 8-36, 8-38
Inverters	8-11, 8-12
Liability	8-5
Maintenance	8-9
Metering	8-4, 8-5
Operating Requirements	8-4
Protective Schemes	8-7, 8-8
Records	8-9
Specifications	8-10
Telemetry	8-8
Testing and Evaluation	8-10
Transformer Requirements	8-3
Parallel Connection of Utility Sources (Double-Ended Switchboards)	1-38
Pedestal, Meter and Service, Commercial Services	2-44
Plans, Design and Approval	1-8
Post, Meter and Service, Mobile Home (Trailer) Services	2-48
Protection, Service Equipment (Barrier Posts)	5-15, 5-17, 5-18
Pull Boxes, Underground Service Terminations	2-15, 2-16, 2-18, 2-20, 2-22, 2-24, 2-36, 2-44, 2-48
Pull sections, Underground Service Terminations	3-9, 3-44, 3-46, 4-18

R

Remote Metering	2-34, 3-6
Risers, Conduit	6-6

S

Safety Barrier, Pull Section	2-12, 3-44, 3-46
Safety-Socket Meter Panel	2-26, 2-28
Scheduling Outages	1-39
Sealing Requirements (panels)	2-9, 3-10, 4-3
Generation Systems	1-17, 1-32, 8-1

INDEX AND GLOSSARYDate: 05-02-24

INDEX (Cont.)**S (Cont.)**

Service Heads	7-14
Service Disconnects:	
Generator Disconnects	8-6
Locking Provisions	2-7, 3-7, 3-8, 4-3, 8-6
Meter Switch	2-6, 3-7, 4-3
Service Main Switch (Group Metering)	2-7, 3-8
Service Drops, Overhead Services	7-2
Service Entrance Conductors	7-14
Service Head locations	7-15
Service Locations	6-2
Service Main Switch-Group Metering	2-7, 3-8
Service Pedestal, Commercial	2-44
Service Planning Offices	1-4
Service Pole, Permanent	7-24, 7-26, 7-28
Service Pole, Temporary	7-22
Service Post, Mobile Home (Trailer) Services	2-48
Service Voltages, Standard	1-25
Short Circuit Current	1-28
Solar Parallel Generating Systems	8-3, 8-5, 8-6, 8-8, 8-10, 8-15, 8-16, 8-17, 8-18, 8-20, 8-22
Small Lot Subdivision	5-32
Swabbing Conduits	6-6
Swimming Pool Clearances	7-8
Switchboards, Low-Voltage:	
Approvals	3-3
Barriers	3-4
Hinged Meter Panel	3-16, 3-18,
Instrument-Transformer Compartments	3-20, 3-22, 3-24, 3-26, 3-28
Outdoor (weatherproof)	3-38
Pull Sections	3-9, 3-44, 3-46
Self-Contained Meters	3-4, 3-34, 3-36
Switchgear, Medium-Voltage:	
Approvals	4-2
Compartment Barriers	4-2
Current-Transformer Mounting Base	4-16
Instrument-Transformer Compartments	4-6, 4-12, 4-15, 4-21, 4-22, 4-27
Pull Sections	4-18
Voltage-Transformer Mounting Rail	4-16
Weatherproof Enclosures	4-3

T

Temporary Services	1-15, 1-29, 5-18, 7-22, 7-24, 7-26
Terminating Enclosures-Low Voltage	2-15, 2-16, 2-18, 2-20, 2-22, 2-24, 2-36, 2-44, 2-48, 3-9, 3-44, 3-46
Terminating Enclosures, Medium Voltage	
601-4800 Volts	4-18
34500 Volts	4-34
Terminating Facilities, Supply Cable, Pressure Type	2-20, 2-24, 2-44, 2-48
Terminating Facilities, Supply Cable, Stud-Type	2-12, 2-16, 2-40, 2-42, 3-44, 3-46, 4-18
Test-Bypass Blocks	2-32

INDEX (Cont.)

T (Cont.)

Totalizing Services	3-5
Transformers:	
Pad-Mounted Installations	1-35
Access and Clearances	1-36
Indoor Installations	1-35
Outdoor Installations-Enclosed Concrete Pad	1-35
Pole-Mounted Installations	1-34
Standard Installations	1-36
Underground Vault Installations	1-35

V

Ventilation Openings	3-11, 4-3
Voltage Transformers, 34500 Volts	4-30
Voltage Transformer Compartments:	
601-4800 Volts	4-5
34500 Volts	4-22, 4-23
Voltage Transformer Mounting Rails:	
601-4800 Volts	4-16
34500 Volts	4-31

W

Weatherproof Metering Enclosures	3-38, 4-5, 4-21
Welders	1-22
Wiring and Connections, Meter Sockets	2-6
Working Space and Clearances:	
0-600 Volt Installations	5-12
601-4800 Volt Installations	5-16
34500 Volt Installations	5-18

X

X-Ray Equipment Loads	1-22
-----------------------------	------

EUSERC/ESR CROSS REFERENCE AND ACCEPTABILITY INDEX

The Department of Water and Power's (Department) Electric Service Requirements (ESR) are in general agreement with the service and metering equipment requirements of the Electric Utility Service Equipment Requirements Committee (EUSERC). Where differences occur between the Department's ESR and the EUSERC requirements, the ESR requirement specified shall take precedence.

EUSER	ESR	A/C
301	2-20	A
301A	---	U
301B	---	N/A
302	---	U
302A	2-22	A
302B	---	U
303	---	U
304	2-26	A
305	2-26	A
305A	2-28	C
306	3-36	A
307	2-48	A
308	2-44	A
308A	---	N/A
309	---	U
310	---	N/A
311	2-32	A
312	---	A
313	2-38	A
314	2-36	C
315	2-18	A
316	---	U
317	---	U
318	---	U
319	3-20	A
320	3-22	A
321	3-24	A
322	3-26	A
323	---	U
324	3-28	A
325	3-12	C
326	3-14	C

EUSER	ESR	A/C
327	3-44	A
328A	2-40	A
328B	2-41	C
329A	2-42	A
329B	2-43	C
330	3-30	A
331	3-32	A
332	3-16	C
333	---	U
336	---	U
337	---	N/A
338	---	U
339	2-34	A
341	---	N/A
342	2-24	A
343	2-16	A
343A	---	U
344	2-15	C
345	3-44	A
346	---	U
347	2-12	C

EUSER	ESR	A/C
348	3-40	C
349	3-48	C
351	---	U
353	3-36	A
354	3-38	C
401	4-6	C
404	---	NA
---	---	---
407	4-14	C
408	4-10	A
409	---	N/A
411	4-12	C
414	---	N/A
416	---	N/A
418	4-18	C
420	4-36	C
---	4-21	N/A
---	4-22	N/A
---	4-26	N/A
---	4-27	N/A
---	4-30	N/A
---	4-31	N/A
---	4-32	N/A
---	4-33	N/A
---	4-34	N/A
501	---	N/A
502	---	N/A
503	---	N/A
515	---	N/A
516	---	N/A
517	---	N/A
518	---	N/A
519	---	N/A

Table Codes:

A/C Acceptance Codes:

- A Department accepts EUSERC drawing.
- U Department does not accept EUSERC drawing.
- C Department accepts EUSERC drawing with some variations – consult ESR page for requirements.
- NA Not applicable to the Department's service area

Note: See Page 9-10 for a listing of the differences between EUSERC drawings and Department ESR pages.

 Indicates latest revision

Date: 05-02-24

INDEX AND GLOSSARY**EUSERC/ESR CROSS REFERENCE AND ACCEPTABILITY INDEX (Cont.)**

The following is an explanation of the Consult (C) references shown in the preceding Table:

<u>ESR PAGE</u>	<u>EUSERC DRAWING</u>	<u>DESCRIPTION</u>
2-12	347	The EUSERC Drawing includes an exception to Note 1 that permits edge-wise terminating facilities to have 9/16-inch holes in place of the studs. The Department does not allow back-to-back termination option shown in Figure 3.
2-15	344	The Department's requirement has a different conduit range and specifies a pull box size for 5-inch conduit.
2-28	305A	The Department requires a one inch (minimum) dimension from the edge of the compartment access opening to the test-bypass block insulator.
2-36	314	When used as a terminating pull box, the Department limits the service capacity to 400 amperes.
2-41	328B	The Department restricts this current-transformer mounting base application to overhead supply only. Overhead supply means a top supply conduit entry from a weatherhead or a separate underground pull box.
2-43	329B	The Department restricts this current-transformer mounting base application to overhead supply only. Overhead supply means a top supply conduit entry from a weatherhead or a separate underground pull box.
3-12	325	The upper and lower CT compartment flanges are limited to a maximum dimension of 1-1/4".
3-14	326	The upper and lower CT compartment flanges are limited to a maximum dimension of 1-1/4".
3-16	332	The Department requires the removable mounting plate to be drilled to ¼ inch.
3-38	354	The Department has more specific requirements for door hold-open devices.
3-40	348	The Department's requirement includes specifications for switchboards supplied from bus duct and bussed top hat enclosures.
3-48	349	For Customer Station applications, the Department requires one landing position for each 400 amperes of service capacity.
4-6	401	The Department requirement is limited to 5 KV installations and includes expanded and more detailed notes. The Department does not allow for the current transformer compartment to be used as a cable termination section.
4-12	411	The Department requirement is limited to 5 KV installations and includes expanded and more detailed notes. The Department does not allow for the current transformer compartment to be used as a cable termination section.
4-14	407	The Department requirement is limited to 5 KV rated service equipment and the current transformer information is specific to Department applications.
4-18	418	The Department requirement is limited to 5 KV installations and includes expanded and more detailed notes. Additional grounding provisions required.
4-36	420	The Department's requirement is specific to 5kV and 35kV installations. One terminal position is required for each 400 amperes of service with 4" separation between adjacent positions. Alternate top bushing location is not allowed.

GLOSSARY

The following terms are used through these electric service requirements:

Accessible: Capable of being reached conveniently and quickly during normal business hours for construction, operation, maintenance, inspection or testing without requiring Department personnel to climb over or remove obstacles; or to obtain special permission or security clearances. Some installations may require 24-hour access.

ADU: Accessory Dwelling Unit

AC-Coupled storage: Both a Parallel Generator and a BESS resource are connected by a common AC (alternating-current) bus, see "BESS"

Across-the-line starting current: The electrical current required by a motor at starting with full line voltage and frequency, and with normally driven load mechanically connected. A stop-ammeter having not more than 15-percent over swing, or an oscillograph, shall be used when it is necessary to determine the starting current. Values indicated by the oscillograph during the first 10 cycles following energizing of the motor shall be disregarded.

Aggregate Capacity: The total capacity of dissimilar energy sources located on a customer's premises.

AHJ: Authority Having Jurisdiction, see "Inspection Authority"

ANSI: American National Standards Institute

Application: A request for electric service connection made to a Department Customer Service Branch Office.

Approved: The facilities installed by the customer are acceptable meets with the Department's service requirements, Rules, and policies.

Arc Flash: The light and heat produced as part of an arc fault, a type of electrical explosion or discharge that results from a connection through air to ground or to another voltage phase in an electrical system.

AWG: American Wire Gauge

Barriers: See Isolating Barriers

BESS: Battery Energy Storage System

Building: A structure standing alone, used for or intended for supporting or sheltering any use or occupancy, and requiring a separate permit by the permitting agency for each separate building or structure.

Bus, Live: Bus bars which are electrically energized.

Busway (Bus Duct): A raceway structure enclosing bus bars and equipped used to connect metering equipment to the point of service.

Cablebus: A raceway structure used in Customer Station installations to enclose the Department's service supply conductors. The structure is furnished and installed without supply conductors by the customer in accordance with the Department's specifications.

Commercial Station: An indoor or enclosed outdoor transformer facility installed on a customer's premises and supplied from the Department's 4800-volt electric system.

GLOSSARY (Cont.)

Conductors, Service Entrance: The conductors installed by the customer from the service point to the service and metering equipment and conforming to the City of Los Angeles electric code or other applicable governing code.

Conductors, Service Supply: The conductors installed by the Department from the supply source to the customer's service point.

Conduit: A pipe manufactured of Department-approved materials, whether direct buried or concrete encased, used to enclose electric conductors.

Current Transformer: An instrument transformer designed for use in the measurement of electrical current.

Customer: The owner, whether a person or business association, or any person or agency authorized to represent the owner's interests.

Customer Generator: A device installed and operated by a customer to supply electric energy to all, or part of, a customer's load. See "Stand-Alone Generator" and "Parallel Generator".

DC-Coupled storage: Both a Parallel Generator and a BESS resource are connected by a common DC (direct-current) bus, see "BESS"

Department: The Los Angeles Department of Water and Power.

Dog House: A common term for a weatherproof enclosure built by the customer on the exterior of a building or other structure and used to enclose indoor service and metering equipment.

Emergency Generator: A customer generator used to supply electrical energy to all, or part of, a customer's load when the Department's electric system has been de-energized. See "Customer Generator".

EUSERC: Electric Utility Service Equipment Requirements Committee.

EXO: Any assembled service wiring installation which does not use a switchboard.

Final Grade: The ground surface elevation after paving and improvements have been completed.

First Floor: The building floor that is closest to the elevation of, and above, the ground level.

Housekeeping Pad: A raised portion of the floor or a raised concrete foundation (pad) installed beneath service and metering equipment and generally intended to keep the equipment out of standing water.

Industrial Station: A transformer installation located on the customer's premises and supplied from the Department's 34,500-volt electric system.

Inspection Authority: Those City, County, State, and Federal agencies responsible for issuing electrical permits, making inspections of the customer's electrical wiring system, and for notifying the Department if such system meets all applicable codes and ordinances and is ready for service. Also known as Authority Having Jurisdiction (AHJ).

Instrument Transformer: A transformer that produces in its secondary circuit, a definite and known proportion of the current or voltage in its primary circuit.

GLOSSARY (Cont.)

Intermittent Duty Operation: A service characteristic where the load conditions are regularly repeated or demand alternating operation. A motor operation is considered to be intermittent if it is controlled by automatic switches (Actuated by pressure, liquid level, temperature, or other similar means), or the operating cycle has more than four starts in any 8-hour period and is not normally manually controlled.

Isolating Barrier: A partition of either conductive or nonconductive material used to mechanically isolate internal compartments or sections from other integral compartments or sections of the enclosure.

Metered Circuits: Those conductors extending from the secondary side of the meter to the customer's load circuits or outlets connected to such circuits.

Meter, Instrument-Transformer Rated: An electrical meter that is connected to a circuit through instrument transformers (i.e., current-transformers and, when required, voltage transformers) and used to accurately measure and register all the electrical energy consumed in the circuit.

Meter Room: A weatherproof, fully illuminated room, provided at the customer's option and approved by the Department.

Meter Panel: A panel used exclusively for mounting meter sockets and associated equipment.

Meter, Self-Contained: An electrical meter that is connected directly into a circuit and is used to accurately measure and register all the electrical energy consumed in the circuit.

Meter Sequence, Hot: An electrical meter that is connected to a circuit on the utility-side or line-side of the meter switch. Turning off the meter switch does not de-energize the meter. Formally known as New Sequence.

Meter Sequence, Cold: An electrical meter that is connected to a circuit on the load-side of the meter switch. Turning off the meter switch will de-energize the meter. Formally known as Old Sequence.

Microgrid: An interconnected system of loads and energy resources, including, but not limited to, distributed energy resources, energy storage, demand response tools, or other management, forecasting, and analytical tools, appropriately sized to meet customer needs, within a clearly defined electrical boundary that can act as a single, controllable entity, and can connect to, disconnect from, or run in parallel with, larger portions of the electrical grid, or can be managed and isolated to withstand larger disturbances and maintain electrical supply to connected critical infrastructure.

NEMA: National Electrical Manufacturers Association

NRTL: Nationally Recognized Testing Laboratory; A private organization that applies its own unique registered certification mark after performing product safety tests on certain products according to a proprietary set of testing standards.

Operating Convenience: The utilization, under certain conditions, of facilities or practices not usually employed which contribute to the overall efficiency of the Department's system.

Parallel Generator: A customer generator used to supply electrical energy to all, or part of, a customer's load and operated, or switched, in parallel with the Department's electric system. See "Customer Generator".

Point of Common Coupling (PCC): The point where the electrical conductors of the Department's distribution system are connected to the customer's conductors and where any transfer of electric power between the customer and Department takes place. See "Service Point".

GLOSSARY (Cont.)

Premises: Integrated land area including improvements thereon, undivided by public thoroughfares or railroads and where all parts of the Premises are operated under the same management or for the same purpose. A division of the integrated land area may be permitted for electric service to industrial, agricultural, oil fields, resort enterprises, and public or quasi-public institutions. "Public or quasi-public institutions" include public utilities, publicly owned educational institutions, privately owned universities, colleges, and hospitals. Indications of "Same Management" include, but are not limited to, common access, parking, lighting, landscaping, and combined maintenance of common areas. A single premises may consist of several lots, properties and/or joint/multiple owners and/or several businesses.

Pull Box: A wall-mounted, fully-enclosed, metal enclosure used to connect the service supply conductors to the service entrance conductors.

Pull Section: A floor-standing, open-bottomed, metal enclosure used to connect the service supply conductors to the service entrance conductors.

Raceway, Overhead: The conduit or sealable wiring enclosure from the service head to the meter socket box, current-transformer box, instrument-transformer compartment, or disconnect device used, that is used to enclose the service entrance conductors.

Raceway, Underground: The conduit or sealable enclosure between the terminating enclosure and the meter socket box, current-transformer box, instrument-transformer compartment, or disconnect device, that is used to enclose the service entrance conductors.

Rules: The document, approved by the General Manager and the Board of Water and Power Commissioners, governing water and electric service in the Department and Water and Power service territory.

Sealing Ring: A device, supplied by the electrical equipment manufacturer, used to hold socket type meters in place with provisions for installing the Department's sealing devices.

Sealing Rings, Security: A heavy-duty sealing ring, supplied by the Department, incorporating an integrated a barrel-lock device.

Security Area: Any area of a premises not readily available to public access, or requiring special permission or security clearances for access.

Self-Generation: See Parallel Generator.

Service Drop: The Department's overhead conductors extending from the Department's pole line to the point of attachment on the building or structure.

Service Entrance Conductors, Overhead: All conductors (including bus or cable) installed by the customer from the service equipment to the point of connection with the Department's service drop conductors.

Service Entrance Conductors, Underground: All conductors (including bus or cable) installed by the customer from the service equipment to the point of connection with the Department's service lateral conductors.

Service Location: The place on the customer's property line where the Department-installed conduits connect to the conduits specified by the Department and installed by the customer.

GLOSSARY (Cont.)

Service Lateral: The span of conductors installed underground in conduit by the Department from a supply source to an approved terminating enclosure.

Service Point: The location of connection between the Department's facilities and the customer's premises wiring. See "Point of Common Coupling".

Stand-Alone Generator: A customer generator used to supply electrical energy to all of, or part of, a customer's load; isolated from the Department's electric system with a non-paralleling switching arrangement, and using the Department's electric system as a standby service. See "Customer-Owned Generators".

Switchboard Service Section: A floor-standing, metal enclosure used to terminate service conductor and having provisions for the Department's electric meters and associated equipment, and containing the customer's meter switch.

Switchboard, Specially Engineered: A switchboard that does not conform to the standard switchboard design and includes one or more of the following conditions: (1) where the service exceeds 600 volts; (2) where the service voltage is 3 ϕ , 3-wire; (3) where the meter switch rating exceeds the ampacity of the standard service section; (4) where the instrument-transformer compartment is supplied from a pull section located below the section (bottom-feed); (5) where multiple-metering sections are used; (6) where recessed meter panels are used.

Switchboard, Standard: An electrical switchboard with an instrument-transformer compartment and hinged meter panels, and the customer's meter switch.

Switch, Service Main: The breaker, fused-switch, or other approved disconnecting means with overcurrent protection located on the line side of two or more meters sockets.

Switch, Meter: The circuit breaker, fuse-switch, or other approved disconnecting means with overcurrent protection located on the load side of a meter and controlling all of, and only, the energy registered by the meter (hot sequence).

Terminating Enclosure: A Department-approved enclosure (i.e., pull box or pull section, or bussed switchboard extension) installed at the underground point of service delivery and used for terminating the Department's service conductors and for joining the conductors to the customer's service entrance conductors.

Test-Bypass Disconnect Facilities (Test-Blocks): An assembly used in conjunction with a self-contained meter socket and designed to allow the Department to de-energize the meter socket without disconnecting service to the customer.

Test Switch: A device incorporating an arrangement of small knife switches connected in the secondary instrument-transformer circuit between the instrument transformers and the associated meter. The test switch is safety device installed by the Department and used to isolate the meter from the instrument transformers.

Test Perch: A bracket designed for mounting the Department's test switch.

Total Capacity: The total capacity of similar energy sources located on a customer's premises.

Voltage Transformer: An instrument transformer designed for use in the measurement of voltage.

Date: 11-18-25

SUMMARY OF 2025 REVISIONS

PAGE	DESCRIPTION OF CHANGES
Title page	Updated contact information
1-1	Added subparagraph "i. Cancellation Policy" to paragraph 9 of subsection B and paragraph "11. Electric Vehicle (EV) Load Management Systems" to subsection C in table of contents
1-2	Added subsection R. Adjustable/Programable Breakers
1-16	Bullet point 2: exchanged "interconnection (1)" for "information" Bullet point 4: deleted "to prepare final agreement (7)" Bullet point 5: exchanged "customer commitment package" for "Agreement for execution (5)" Bullet point 6: added "(2)" and deleted "along with request for interconnection design (1)" Deleted bullet point 7 Bullet point 8 and 9: added ". if applicable" Added "Department executes agreement" as new bullet point 10
1-21	Subparagraph i. Cancellation Policy inserted
1-24	Added "and email" for 2.a
1-28	Added to Note for G. "Field conditions likely to produce higher fault currents will be indicated to the customer by the Department."
1-34	K.1.(b) corrected to state 34,500-volt, not 34,000-volt
1-35	Added "their" for K.2.b.(4)(d)
1-36	Added "their" for K.2.b.(5)(d)
1-39	In the N.3 Exception, changed "customers" to "customer's" Added point N.3.(e) Added point N.3.(f)
1-40	Added a new page and subsection R
2-7, 3-8	Added "The devices will need to be barriered such that they are not contained in the utility sealed section and maintenance can be done without needing to open the utility sealed section." for C.2.a.(2) in Section 2 and G.2.a.(2) in Section 3
3-3	A.4: removed "Mail four" and placed "Email" in its place. Added the word "the", capitalized "D" for design, and added comma between Electric Vehicle and PV/BESS A.5: Capitalized "Service Planning"

Date: 09-03-25

SUMMARY OF 2025 REVISIONS

PAGE	DESCRIPTION OF CHANGES
3-37	Added for Note 3: "For Protrusions not more than 2 inches in height and which are related specifically to compartment components such as an individual breaker cover, sealing provisions, venting, etc., the minimum "B" clearance can be reduced to 3-3/4 inches." This reflects that the EUSERC standard changed.
4-2	Add "Email copies of the" for B.4 and removed the mailing information Corrected B.4 and 5 to state "switchgear"
5-10	Corrected spelling of "absorption" in C.7.c.(4)
5-23	Corrected the numbering of H
6-7	Changed subsection N's heading to be "Conduit in a Building Structure" Added point N.1 Clarified point N.2